



HMP - Servo drive systems

■ Introduction

The HeiMotion Premium series of brushless AC servo motors are engineered to meet the most demanding application requirements. Five frame sizes are covering a wide range of torque levels and speeds. Use of our proven compressed winding technology enables the realization of a more compact motor with lower production costs compared to other motors on the market.

The HeiMotion Premium motors are available in five standard frame sizes:

- 40 mm - HMP04
- 60 mm - HMP06
- 80 mm - HMP08
- 100 mm - HMP10
- 130 mm - HMP13

Overview of features:

- Outstanding servo performance in synchronization and precision
- Versatile configurable and customizable
- High efficiency
- Optimized moment of inertia
- Long service life
- Compact design
- High power density
- High overload capacity
- Low cogging torque
- Energy efficiency

■ Contents

General information Page

Overview motors	4
Mating servo drive matrix	5
Operating modes	6
Standards	7
Ambient conditions and technical characteristics	8
Abbreviations and definitions	9
Life span	10
Order code	11

HeiMotion Premium motors Page

HMP04	12
HMP06	16
HMP08	18
HMP10	22
HMP13	24

Options Page

Configuration options	28
Standard resolver	30
Absolute encoder HS/M 16	31
Options EnDat 2.2	32
Options HIPERFACE®	34
Options HIPERFACE-DSL®	36
Options SSI/BISS/Incremental encoders	38
Holding brake	40
Connector Y-Tec	42
Connector M23	44
Connectors for one cable solution	46

Servo drives Page

Servo drives overview	49
HCB servo drive	50
HCL servo drive	56

HMP04

HMP06

HMP08

HMP10

HMP13

Encoder

Brake

Connector

Drives

Overview

HeiMotion Premium motors basic performance values

Type	Model	U_{bus} [V _{DC}]	I_o [A]	I_n [A]	M_o [Nm]	M_n [Nm]	M_{max} [Nm]	n_n [rpm]	J [kg-cm ²]	P_n (S1) [W]
HMP04	HMP04-002	48	1.8	1.7	0.18	0.16	0.6	3,000	3.00E-02	50
		48	3.4	3.0	0.18	0.14	0.7	6,000	3.00E-02	85
		320	0.8	0.7	0.18	0.12	0.7	9,000	3.00E-02	110
	HMP04-004	48	3.5	3.3	0.35	0.32	1.3	3,000	5.40E-02	100
		48	6.3	5.7	0.35	0.28	1.3	6,000	5.40E-02	175
		320	1.6	1.2	0.35	0.21	1.4	9,000	5.40E-02	200
HMP06	HMP06-007	320	0.9	0.8	0.7	0.6	2.8	3,000	2.20E-01	200
		320	1.6	1.3	0.7	0.5	2.8	6,000	2.20E-01	325
	HMP06-015	320	1.8	1.5	1.5	1.2	6.0	3,000	4.13E-01	400
		320	3.3	2.2	1.5	0.9	6.0	6,000	4.13E-01	550
HMP08	HMP08-028	320	3.1	2.6	2.8	2.4	11.2	3,000	1.40E00	750
		320	5.6	3.7	2.8	1.7	11.2	5,500	1.40E00	1,000
		560	1.8	1.6	2.8	2.3	11.2	3,000	1.40E00	750
		560	3.3	2.2	2.8	1.7	11.2	5,500	1.40E00	1,000
	HMP08-035	320	3.9	3.7	3.5	3.2	14.0	3,000	1.93E00	1,000
		320	7.1	4.8	3.5	2.1	14.0	5,500	1.93E00	1,200
		560	2.2	2.1	3.5	3.2	14.0	3,000	1.93E00	1,000
		560	3.9	2.8	3.5	2.1	14.0	5,500	1.93E00	1,200
HMP10	HMP10-056	560	3.4	3.0	5.6	4.8	22.4	3,000	4.84E00	1,500
		560	5.4	3.7	5.6	3.4	22.4	5,000	4.84E00	1,800
	HMP10-075	560	4.6	4.1	7.5	6.4	30.0	3,000	6.41E00	2,000
		560	7.5	5.3	7.5	4.8	30.0	5,000	6.41E00	2,500
HMP13	HMP13-055	320	4.8	4.1	5.5	4.8	22.0	2,000	9.82E00	1,000
		320	8.2	6.0	5.5	4.0	22.0	3,600	9.82E00	1,500
		560	2.7	2.3	5.5	4.8	22.0	2,000	9.82E00	1,000
		560	4.7	3.4	5.5	4.0	22.0	3,600	9.82E00	1,500
	HMP13-091	560	4.4	3.4	9.1	7.2	36.4	2,000	1.40E01	1,500
		560	7.7	5.0	9.1	6.0	36.4	3,600	1.40E01	2,250
	HMP13-123	560	4.7	4.5	12.3	9.6	49.2	2,000	2.11E01	2,000
		560	10.3	6.7	12.3	8.0	49.2	3,600	2.11E01	3,000
	HMP13-185	560	8.4	6.5	18.5	14.4	74.0	2,000	3.38E01	3,000
		560	14.8	8.0	18.5	10.0	74.0	3,600	3.38E01	3,750

HeiMotion Premium motors mating servo drive matrix

Type	Model	n [rpm]	U _{bus} [V _{DC}]	I _o	HCB		HCL 24 - 48 V _{DC}
					1 X 230 V _{AC}	3 X 400 V _{AC}	
HMP04	HMP04-002	3,000	48	1.8	HCB 2/6-1	HCB 4/12-3	
		6,000	48	3.4	HCB 4/12-1	HCB 4/12-3	HCL
		9,000	320	0.8	HCB 2/6-1	HCB 4/12-3	
	HMP04-004	3,000	48	3.5	HCB 4/12-1	HCB 4/12-3	HCL
		6,000	48	6.3		HCB 8/24-3	HCL
		9,000	320	1.6	HCB 2/6-1	HCB 4/12-3	
HMP06	HMP06-007	3,000	320	0.9	HCB 2/6-1	HCB 4/12-3	
		6,000	320	1.6	HCB 2/6-1	HCB 4/12-3	
	HMP06-015	3,000	320	1.8	HCB 2/6-1	HCB 4/12-3	
		6,000	320	3.3	HCB 4/12-1	HCB 4/12-3	
HMP08	HMP08-028	3,000	320	3.1	HCB 4/12-1	HCB 4/12-3	
		5,500	320	5.6		HCB 8/24-3	
		3,000	560	1.8		HCB 4/12-3	
		5,500	560	3.3		HCB 4/12-3	
	HMP08-035	3,000	320	3.9	HCB 4/12-1	HCB 4/12-3	
		5,500	320	7.1		HCB 8/24-3	
		3,000	560	2.2		HCB 4/12-3	
		5,500	560	3.9		HCB 4/12-3	
HMP10	HMP10-056	3,000	560	3.4		HCB 4/12-3	
		5,000	560	5.4		HCB 8/24-3	
	HMP10-075	3,000	560	4.6		HCB 8/24-3	
		5,000	560	7.5		HCB 8/24-3	
HMP13	HMP13-055	2,000	320	4.8		HCB 8/24-3	
		3,600	320	8.2		HCB 12/30-3	
		2,000	560	2.7		HCB 4/12-3	
		3,600	560	4.7		HCB 8/24-3	
	HMP13-091	2,000	560	4.4		HCB 8/24-3	
		3,600	560	7.7		HCB 8/24-3	
	HMP13-123	2,000	560	4.7		HCB 8/24-3	
		3,600	560	10.3		HCB 12/30-3	
	HMP13-185	2,000	560	8.4		HCB 12/30-3	
		3,600	560	14.8			



HCB
p. 50



HCL
p. 56

Operating Modes

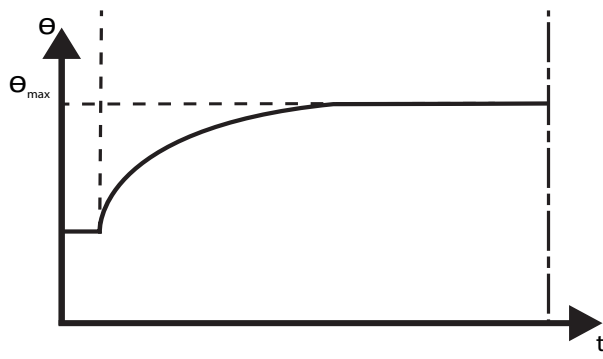
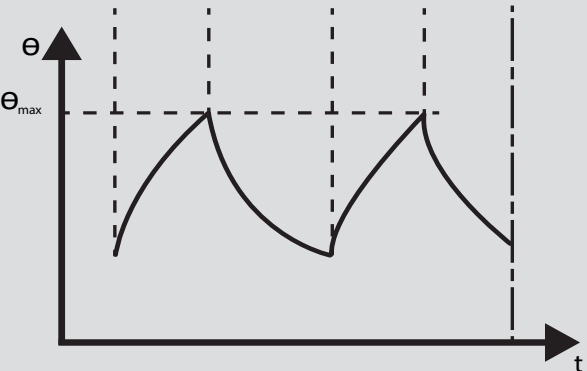
	Definition	Graph
S1	Continuous operation with constant load	
S3	Periodic intermittent operation without influence of the starting process on motor heating	

■ Applied harmonized standards

Standard	Explanation
EN ISO 12100:2010	Safety of machinery General design principles Risk assessment and risk reduction
EN 60034-1:2010 + Cor.:2010	Rotating electrical machines Part 1: Dimensioning and operating behavior
EN 60204-1:2018	Safety of machinery Electrical equipment of machines Part 1: General requirements
EN 60529:1991 + A1:2000 + A2:2013	Degrees of protection by enclosure (IP code)
EN IEC 60664-1:2020	Insulation coordination for equipment in low-voltage power supply systems Part 1: Principles, requirements and tests

■ General information

Ambient conditions and technical characteristics

Motor type	Permanent magnet three-phase synchronous servo motor	
Ambient operating temperature	- 10 °C to + 40 °C	
Ambient storage temperature	- 20 °C to + 70 °C	
Humidity	< 90 % relative humidity (without condensation)	
Insulation class	F (155 °C) $\Delta T = 115 K$	
Pollution level	2	
Protection class	IP65 (standard version), (except drive end, protection class is IP21, without shaft oil seal)	
Cooling	Natural convective	
Oversvoltage category	HMP04: II max. 3000 meter above sea level; I max. 4000 meter above sea level HMP06 to 13: II max. 4000 meter above sea level	
Bearing life	20,000 h under rated operation conditions (M_r)	
Temperature sensor	PT 1000; optional KTY	
Voltage slew rate dU / dt	8 kV / μs	
Maximum altitude	4,000 meters above sealevel; derate 1% per 100 meters above 1,000 meters	
Concentricity, coaxiality, and axial run-out	N (normal) per DIN 42955	
Vibration	Stage N in accordance to ISO 2373	
Cogging torque factor c_t	HMP04	< 2.8 % based on the stall torque (M_o)
	HMP06	< 2.5 % based on the stall torque (M_o)
	HMP08	< 2.0 % based on the stall torque (M_o)
	HMP10	< 1.7 % based on the stall torque (M_o)
	HMP13	< 1.5 % based on the stall torque (M_o)
Coating	Black top coat, RAL 9005	
Magnet material	Neodymium-Iron-Boron (NdFeB)	
Shaft end	Cylindrical shaft end with / without keyway	
Balancing quality	Q 2.5	
Encoder systems	Resolver, HIPERFACE®, HIPERFACE DSL®, Incremental encoder, SSI/BiSS, EnDat 2.2	
Approvals	CE,  - certification (see E341694)	

Abbreviations and definitions

Abbr.	Unit	Tolerance	Explanation
f_n	[Hz]	-	Rated frequency
I_0	[A _{rms}]	± 10 %	Stall current per phase (motor current at stall torque M_0)
I_n	[A _{rms}]	± 10 %	Rated current (rated current per phase)
I_{max}	[A _{rms}]	-	Peak current (maximum permissible current per phase)
J	[kg·cm ²]	-	Moment of inertia rotor (motor without brake)
k_e	[V _{rms} / krpm]	± 4 %	Voltage constant (induced voltage between two phases at 1,000 rpm) rms (root mean square value)
k_{tn}	[Nm / A _{rms}]	± 6 %	Torque constant (rms) at nominal point at 20 °C
L_{p-p}	[mH]	-	Winding inductance (2 phases) at rated current I_n
m	[kg]	-	Weight (motor without brake)
M_0	[Nm]	± 10 %	Stall torque (stall torque at S1)
M_n	[Nm]	± 10 %	Rated torque (continuous torque at S1)
M_{max}	[Nm]	-	Peak torque (maximum permissible torque for short periods)
n_n	[rpm]	-	Rated speed
n_{max}	[rpm]	-	Maximum speed
P_n	[W]	-	Rated power (mechanical power at the shaft)
R_{p-p}	[Ω]	± 5 % ± 10 %	Winding resistance (2 phases, at winding temperature of 20 °C), ± 5 % for 320/560 V _{DC} , ± 10 % for 24/48 V _{DC} motors
C_t	[%]	-	Local cogging torque $C_t = \frac{M_{cmax} - M_{cmin}}{M_0} \times 100 \%$
M_{cmax}	[Nm]	-	Local maximum of the cogging torque
M_{cmin}	[Nm]	-	Local minimum of the cogging torque
T_{el}	[ms]	-	Electrical time constant
T_{th}	[min]	-	Thermal time constant
U_{mot}	[V _{rms}]	-	Rated motor voltage (2 phases at rated working point), rms
U_{bus}	[V _{DC}]	-	DC bus voltage

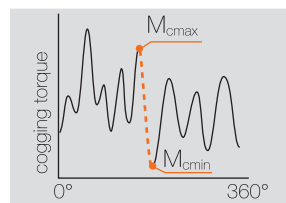

Life span

Shaft loading forces

Life span of the motors is at least 20,000 hours if operated under rated conditions. The table below shows admissible radial forces for the bearing load. Point of force application is in the middle of the shaft (see drawing).

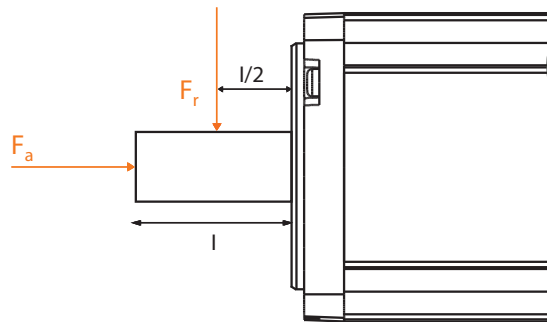

Maximum radial force F_r , [N]

	1,000 [rpm]	2,000 [rpm]	3,000 [rpm]	4,000 [rpm]	5,000 [rpm]	6,000 [rpm]	7,000 [rpm]	8,000 [rpm]	9,000 [rpm]
HMP04-002	215	170	150	135	125	120	115	110	105
HMP04-004	235	185	160	150	135	130	125	120	115
HMP06-007	350	290	250	230	210	200	190	180	-
HMP06-015	390	310	270	250	230	220	205	195	-
HMP08-028	500	400	350	320	300	270	260	-	-
HMP08-035	520	410	360	320	300	280	265	-	-
HMP10-056	940	740	650	590	550	515	-	-	-
HMP10-075	970	770	680	615	570	540	-	-	-
HMP13-055	820	650	570	510	480	-	-	-	-
HMP13-091	860	680	590	540	500	-	-	-	-
HMP13-123	1,100	900	790	710	660	-	-	-	-
HMP13-185	1,200	960	840	760	700	-	-	-	-

Maximum axial force: $F_a = 0.2 \times F_r$

At stall, a one-time axial force of 40 % of the radial force may be applied during motor mounting. Maximum allowed axial and radial forces must not occur together at the same time.

■ HMP04-002



Specifications

HMP04-002

Rated speed [rpm]	n_n	3,000	6,000	9,000
Number of pole pairs		2	2	2
Wiring of the motor winding		Y	Y	Y
DC bus voltage [V _{DC}]	U_{bus}	48	48	320
Rated voltage motor [V _{rms}]	U_{mot}	27	23	140
Rated power [W]	P_n	50	85	110
Rated torque [Nm]	M_n	0.16	0.14	0.12
Rated current per phase [A _{rms}]	I_n	1.7	3.0	0.7
Stall torque [Nm]	M_0	0.18	0.18	0.18
Stall current per phase [A _{rms}]	I_0	1.8	3.4	0.8
Peak torque [Nm]	M_{max}	0.6	0.7	0.7
Peak current [A _{rms}]	I_{max}	5.7	13.0	3.2
Maximum speed [rpm]	n_{max}	5,210	8,800	10,000
Voltage constant at 1,000 rpm [V _{rms}]	k_e	6.2	3.3	13.5
Torque constant [Nm / A _{rms}]	k_t	0.09	0.05	0.17
Winding resistance (2 phases) at 20 °C [Ω]	R_{p-p}	4.9	1.4	25.6
Winding inductance (2 phases) [mH]	L_{p-p}	3.0	0.8	14.8
Electrical time constant [ms]	t_{el}	0.6	0.6	0.6
Thermal time constant [min]	t_{th}	15	15	15
Moment of inertia rotor [kg-cm ²]	J	3.00E-02	3.00E-02	3.00E-02
Weight of motor [kg]	m	0.5	0.5	0.5

Performance

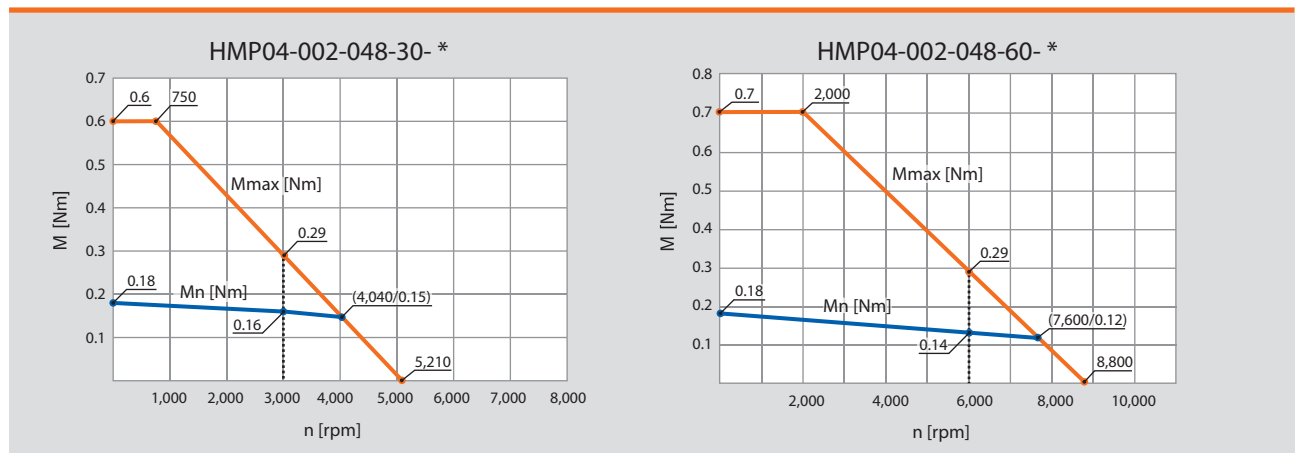

Dimensions

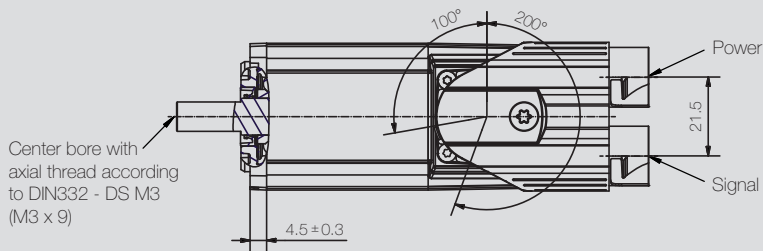
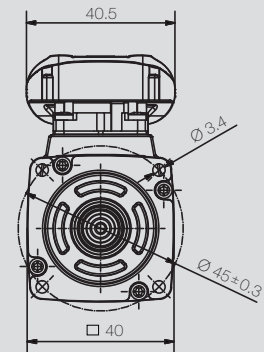
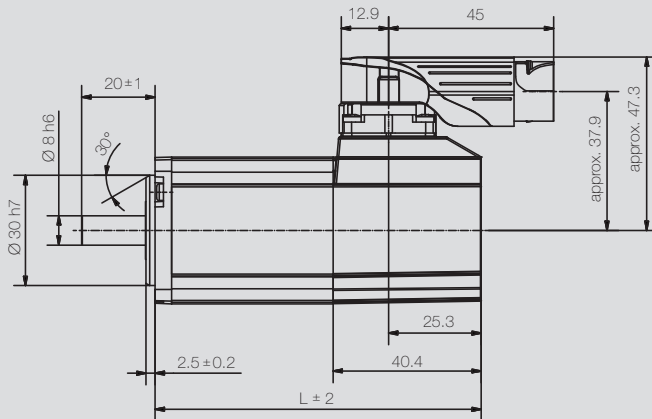

Feather key (option)

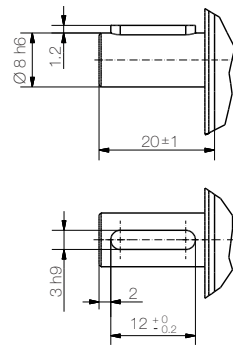

Motor model		L
HMP04-002	without brake	89 mm
HMP04-002	with brake	124 mm

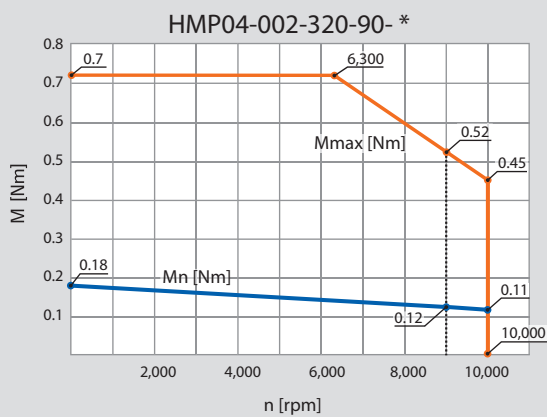

■ HMP04-004



Specifications

	HMP04-004			
Rated speed [rpm]	n_n	3,000	6,000	9,000
Number of pole pairs		2	2	2
Wiring of the motor winding		Y	Y	Y
DC bus voltage [V _{DC}]	U_{bus}	48	48	320
Rated voltage motor [V _{rms}]	U_{mot}	25	23	132
Rated power [W]	P_n	100	175	200
Rated torque [Nm]	M_n	0.32	0.28	0.21
Rated current per phase [A _{rms}]	I_n	3.3	5.7	1.2
Stall torque [Nm]	M_0	0.35	0.35	0.35
Stall current per phase [A _{rms}]	I_0	3.5	6.3	1.6
Peak torque [Nm]	M_{max}	1.3	1.3	1.4
Peak current [A _{rms}]	I_{max}	12.9	23.5	6.4
Maximum speed [rpm]	n_{max}	5,280	9,540	10,000
Voltage constant at 1,000 rpm [V _{rms}]	k_e	6.1	3.4	13.2
Torque constant [Nm / A _{rms}]	k_t	0.10	0.05	0.18
Winding resistance (2 phases) at 20 °C [Ω]	R_{p-p}	1.6	0.4	8.6
Winding inductance (2 phases) [mH]	L_{p-p}	1.4	0.4	6.6
Electrical time constant [ms]	t_{el}	0.9	1.1	0.8
Thermal time constant [min]	t_{th}	15	15	15
Moment of inertia rotor [kg-cm ²]	J	5,40E-02	5,40E-02	5,40E-02
Weight of motor [kg]	m	0.7	0.7	0.7

Performance

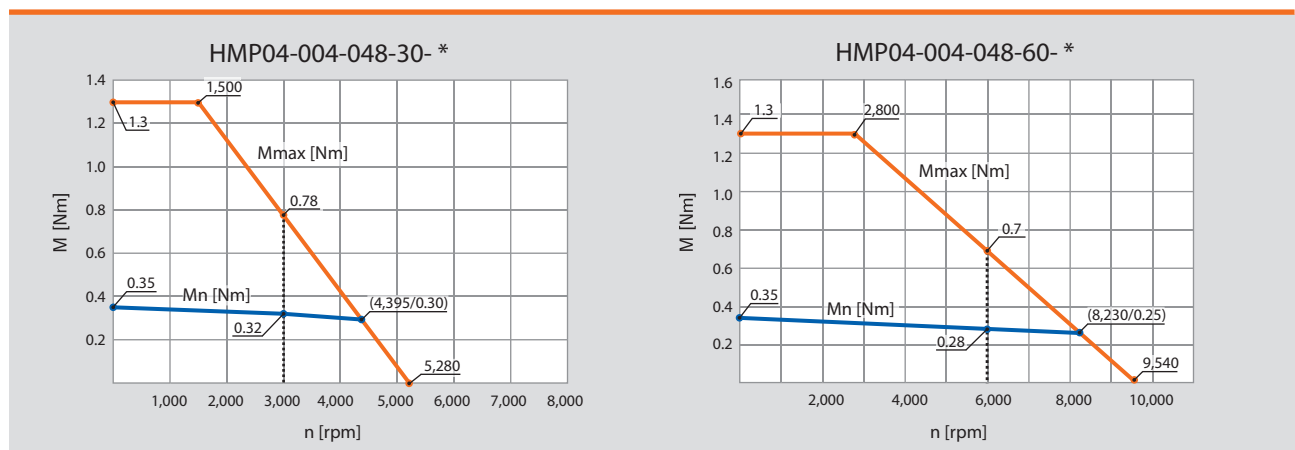

Dimensions

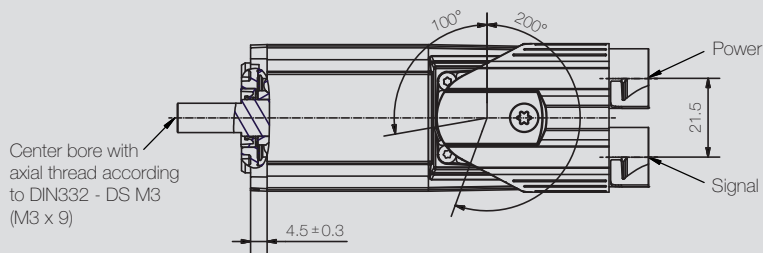
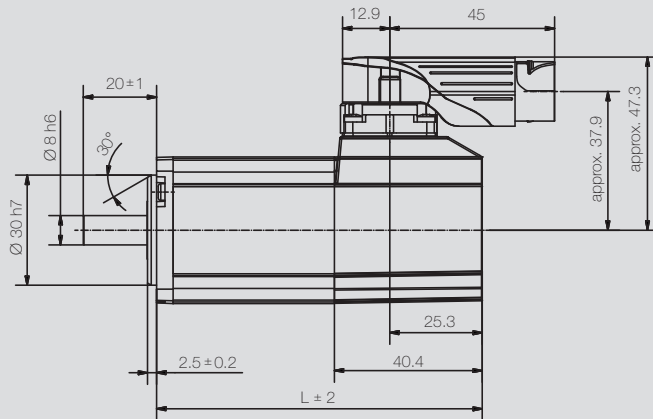

Feather key (option)

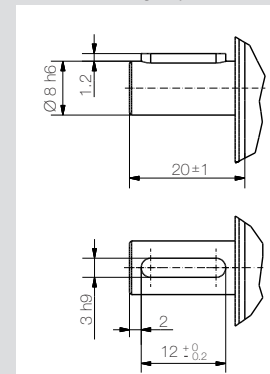

Motor model		L
HMP04-004	without brake	114 mm
HMP04-004	with brake	149 mm

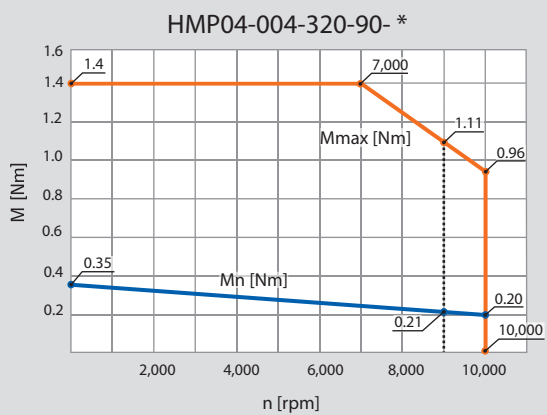

■ HMP06-007 / -015



Specifications

		HMP06-007		HMP06-015	
Rated speed [rpm]	n_n	3,000	6,000	3,000	6,000
Number of pole pairs		3	3	3	3
Wiring of the motor winding		Y	Y	Y	Y
DC bus voltage [V _{DC}]	U_{bus}	320	320	320	320
Rated voltage motor [V _{rms}]	U_{mot}	181	179	181	180
Rated power [W]	P_n	200	325	400	550
Rated torque [Nm]	M_n	0.6	0.5	1.2	0.9
Rated current per phase [A _{rms}]	I_n	0.8	1.3	1.5	2.2
Stall torque [Nm]	M_0	0.7	0.7	1.5	1.5
Stall current per phase [A _{rms}]	I_0	0.9	1.6	1.8	3.3
Peak torque [Nm]	M_{max}	2.8	2.8	6.0	6.0
Peak current [A _{rms}]	I_{max}	3.6	6.4	7.2	13.2
Maximum speed [rpm]	n_{max}	4,400	8,060	4,220	7,350
Voltage constant at 1,000 rpm [V _{rms}]	k_e	49.6	27.1	51.7	27.9
Torque constant [Nm / A _{rms}]	k_t	0.75	0.38	0.80	0.41
Winding resistance (2 phases) at 20 °C [Ω]	R_{p-p}	26.4	8.0	9.8	3.0
Winding inductance (2 phases) [mH]	L_{p-p}	37.6	11.0	18.6	5.4
Electrical time constant [ms]	t_{el}	1.4	1.4	1.9	1.8
Thermal time constant [min]	t_{th}	25	25	25	25
Moment of inertia rotor [kg-cm ²]	J	2.20E-01	2.20E-01	4.13E-01	4.13E-01
Weight of motor [kg]	m	1.45	1.45	2.0	2.0

Performance

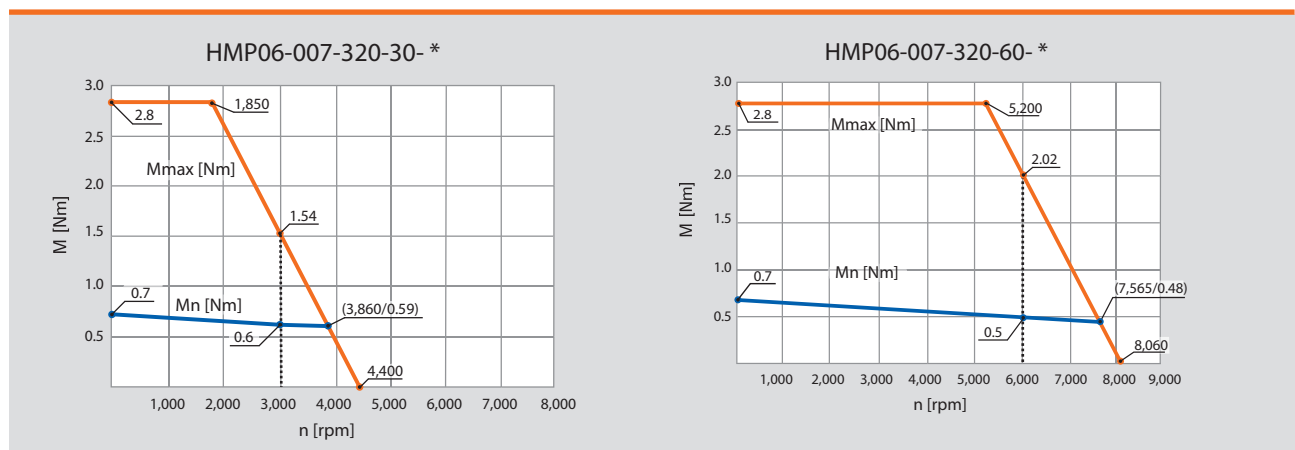

Dimensions

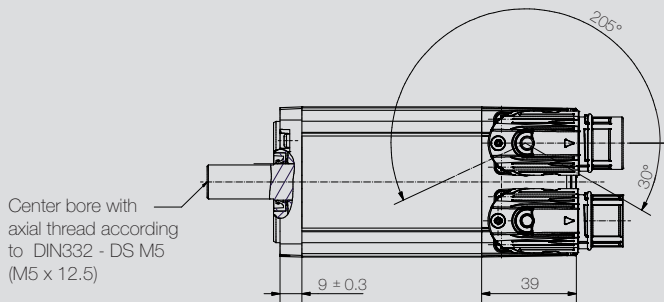
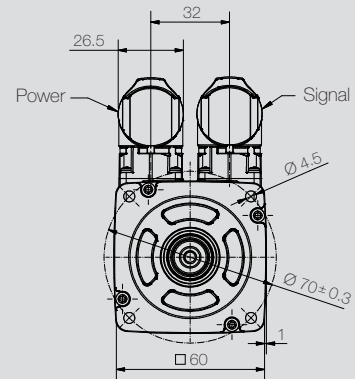
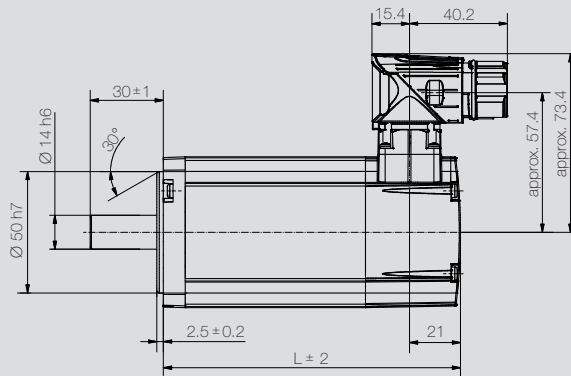

Feather key (option)

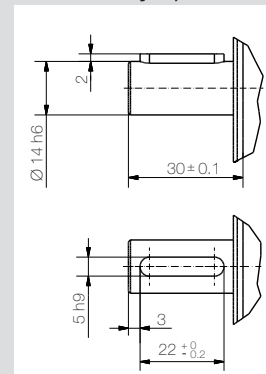

Motor model		L
HMP06-007	without brake	122 mm
HMP06-007	with brake	156 mm
HMP06-015	without brake	152 mm
HMP06-015	with brake	186 mm

HMP06

HMP06-015-320-30-*

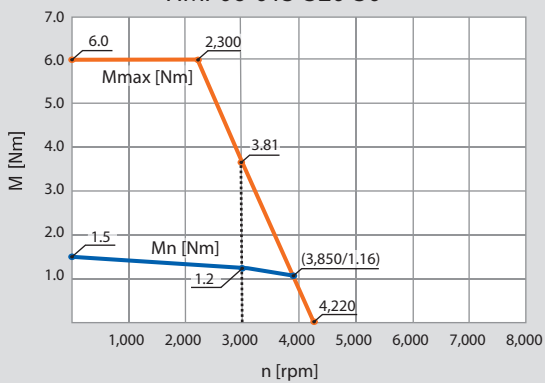

HMP06-015-320-60-*

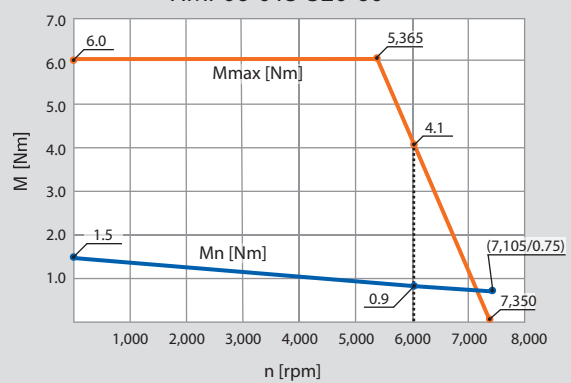

HMP08-028



Specifications

	HMP08-028				
Rated speed [rpm]	n_n	3,000	5,500	3,000	5,500
Number of pole pairs		3	3	3	3
Wiring of the motor winding		Y	Y	Y	Y
DC bus voltage [V _{DC}]	U_{bus}	320	320	560	560
Rated voltage motor [V _{rms}]	U_{mot}	181	179	320	314
Rated power [W]	P_n	750	1,000	750	1,000
Rated torque [Nm]	M_n	2.4	1.7	2.3	1.7
Rated current per phase [A _{rms}]	I_n	2.6	3.7	1.6	2.2
Stall torque [Nm]	M_0	2.8	2.8	2.8	2.8
Stall current per phase [A _{rms}]	I_0	3.1	5.6	1.8	3.3
Peak torque [Nm]	M_{max}	11.2	11.2	11.2	11.2
Peak current [A _{rms}]	I_{max}	12.4	22.4	7.2	13.2
Maximum speed [rpm]	n_{max}	4,020	6,685	3,980	6,760
Voltage constant at 1,000 rpm [V _{rms}]	k_e	54.3	30.7	95.3	54.3
Torque constant [Nm / A _{rms}]	k_t	0.92	0.46	1.44	0.78
Winding resistance (2 phases) at 20 °C [Ω]	R_{p-p}	4.6	1.6	14.2	4.6
Winding inductance (2 phases) [mH]	L_{p-p}	11.8	3.8	36.2	11.8
Electrical time constant [ms]	t_{el}	2.6	2.4	2.5	2.6
Thermal time constant [min]	t_{th}	30	30	30	30
Moment of inertia rotor [kg-cm ²]	J	1.40E00	1.40E00	1.40E00	1.40E00
Weight of motor [kg]	m	3.2	3.2	3.2	3.2

Performance

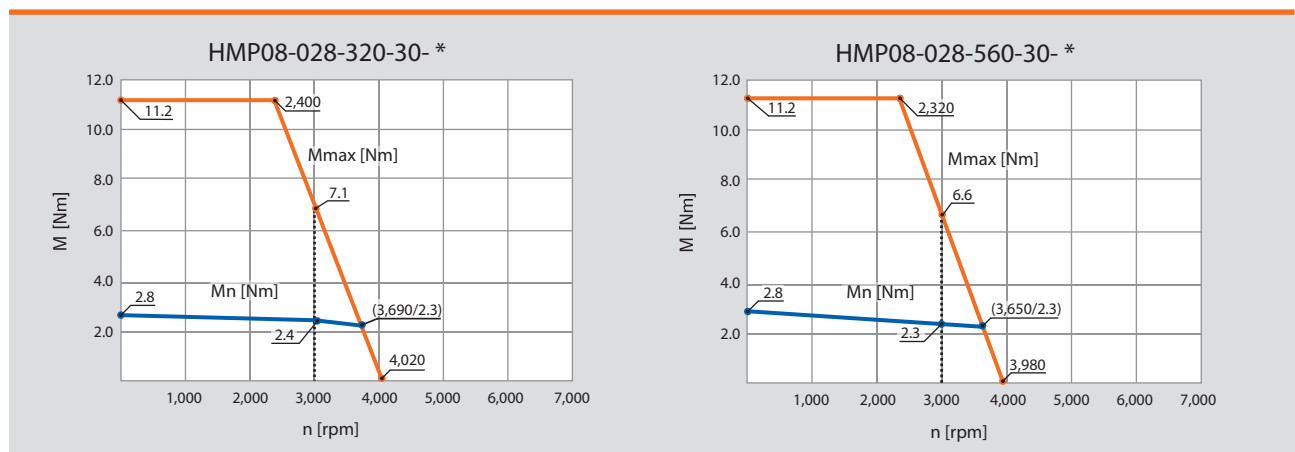

Dimensions

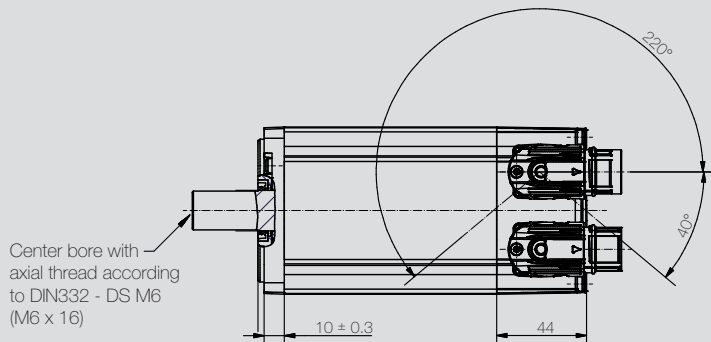
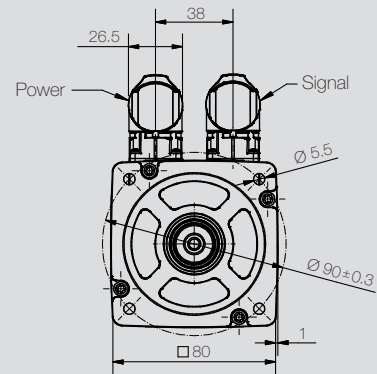
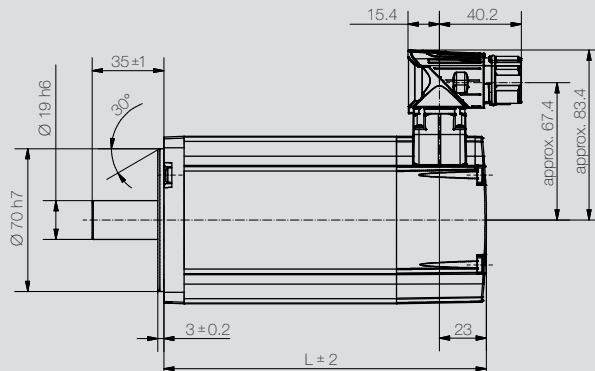

Feather key (option)

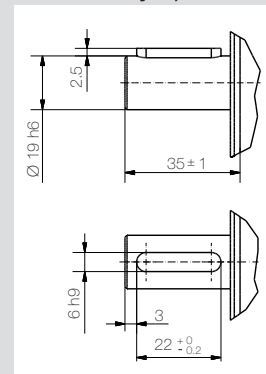

Motor model		L
HMP08-028	without brake	158 mm
HMP08-028	with brake	200 mm

HMP08

HMP08-028-320-55- *

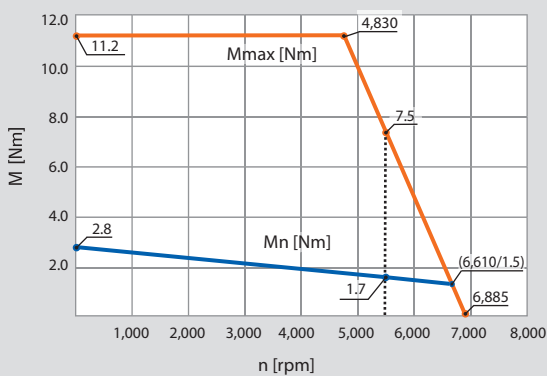

HMP08-028-560-55- *

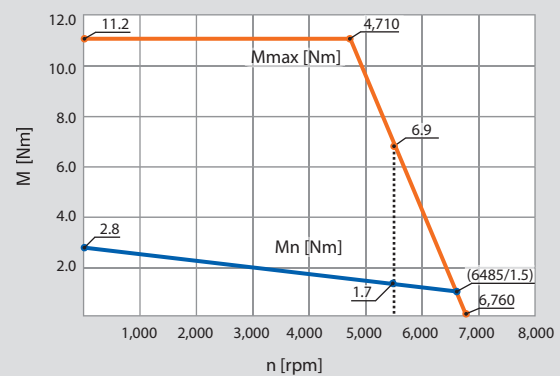

■ HMP08-035



Specifications

	HMP08-035				
Rated speed [rpm]	n_n	3,000	5,500	3,000	5,500
Number of pole pairs		3	3	3	3
Wiring of the motor winding		Y	Y	Y	Y
DC bus voltage [V _{dc}]	U_{bus}	320	320	560	560
Rated voltage motor [V _{rms}]	U_{mot}	181	174	320	316
Rated power [W]	P_n	1,000	1,200	1,000	1,200
Rated torque [Nm]	M_n	3.2	2.1	3.2	2.1
Rated current per phase [A _{rms}]	I_n	3.7	4.8	2.1	2.8
Stall torque [Nm]	M_0	3.5	3.5	3.5	3.5
Stall current per phase [A _{rms}]	I_0	3.9	7.1	2.2	3.9
Peak torque [Nm]	M_{max}	14.0	14.0	14.0	14.0
Peak current [A _{rms}]	I_{max}	15.6	28.4	8.8	15.6
Maximum speed [rpm]	n_{max}	3,970	7,180	3,890	6,680
Voltage constant at 1,000 rpm [V _{rms}]	k_e	55.0	30.4	97.5	55.0
Torque constant [Nm / A _{rms}]	k_t	0.86	0.44	1.52	0.75
Winding resistance (2 phases) at 20 °C [Ω]	R_{p-p}	2.8	0.8	9.0	2.8
Winding inductance (2 phases) [mH]	L_{p-p}	8.4	2.6	26.0	8.4
Electrical time constant [ms]	t_{el}	3.0	3.3	2.9	3.0
Thermal time constant [min]	t_{th}	30	30	30	30
Moment of inertia rotor [kg-cm ²]	J	1.93E00	1.93E00	1.93E00	1.93E00
Weight of motor [kg]	m	3.85	3.85	3.85	3.85

Performance

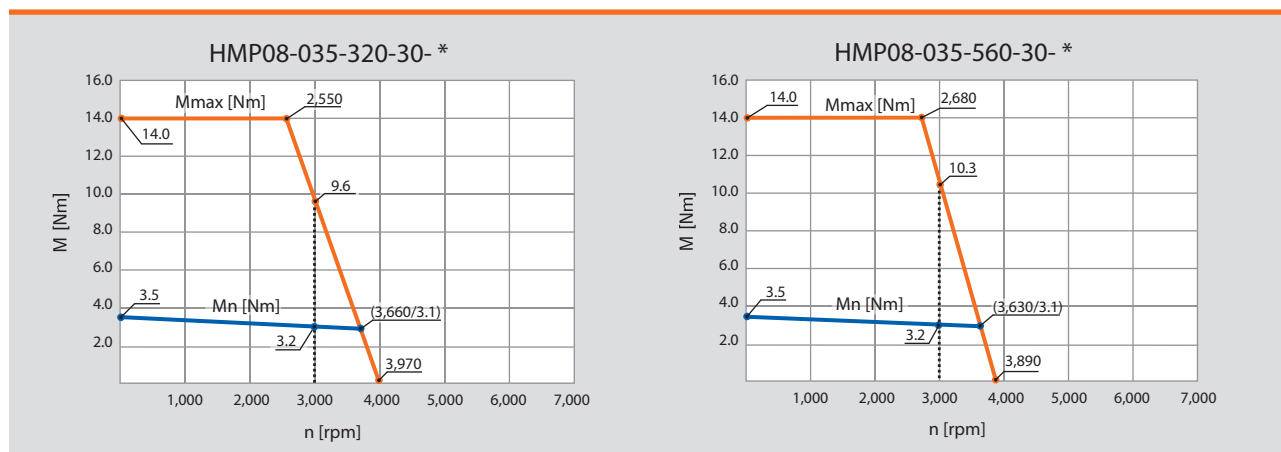

Dimensions

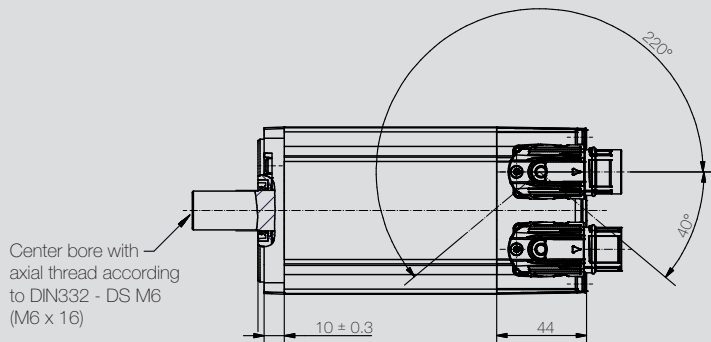
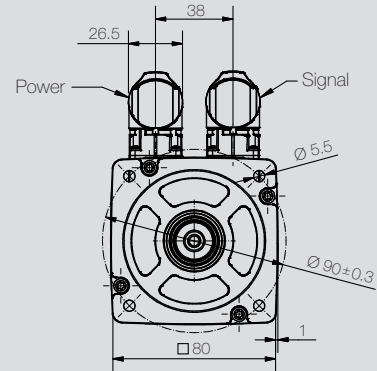
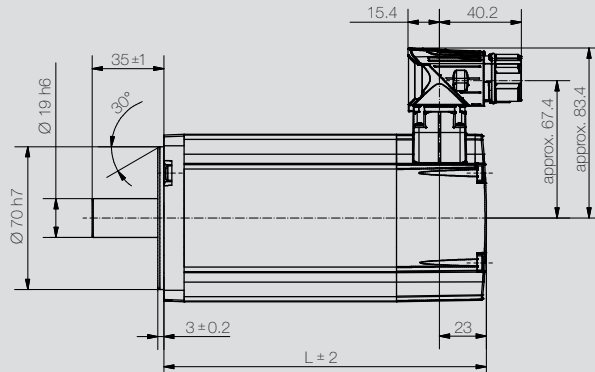

Feather key (option)

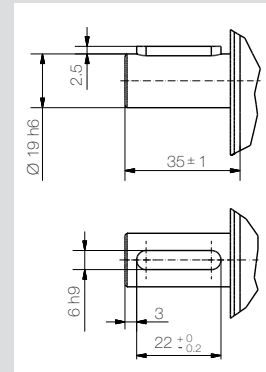

Motor model		L
HMP08-035	without brake	178 mm
HMP08-035	with brake	220 mm

HMP08

HMP08-035-320-55- *

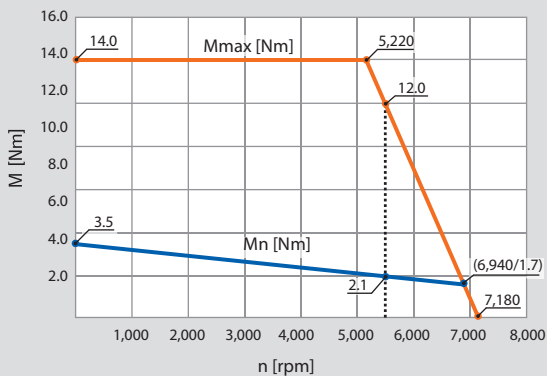

HMP08-035-560-55- *

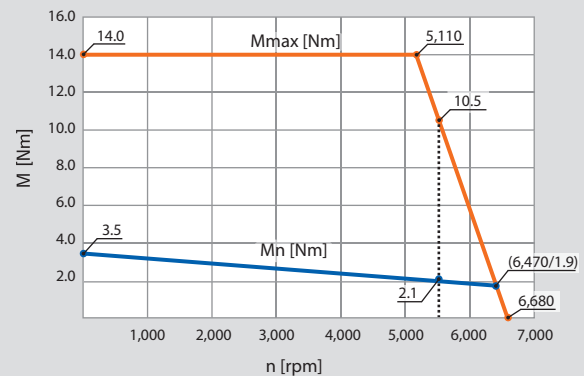

■ HMP10-056 / -075



Specifications

		HMP10-056		HMP10-075	
Rated speed [rpm]	n_n	3,000	5,000	3,000	5,000
Number of pole pairs		3	3	3	3
Wiring of the motor winding		Y	Y	Y	Y
DC bus voltage [V _{DC}]	U_{bus}	560	560	560	560
Rated voltage motor [V _{rms}]	U_{mot}	316	316	320	318
Rated power [W]	P_n	1,500	1,800	2,000	2,500
Rated torque [Nm]	M_n	4.8	3.4	6.4	4.8
Rated current per phase [A _{rms}]	I_n	3.0	3.7	4.1	5.3
Stall torque [Nm]	M_0	5.6	5.6	7.5	7.5
Stall current per phase [A _{rms}]	I_0	3.4	5.4	4.6	7.5
Peak torque [Nm]	M_{max}	22.4	22.4	30.0	30.0
Peak current [A _{rms}]	I_{max}	13.6	21.6	18.4	30.0
Maximum speed [rpm]	n_{max}	3,590	5,810	3,620	5,950
Voltage constant at 1,000 rpm [V _{rms}]	k_e	102.2	63.2	101.4	61.7
Torque constant [Nm / A _{rms}]	k_t	1.60	0.92	1.56	0.91
Winding resistance (2 phases) at 20 °C [Ω]	R_{p-p}	4.6	1.8	3.2	1.4
Winding inductance (2 phases) [mH]	L_{p-p}	19.8	7.4	15.0	5.6
Electrical time constant [ms]	t_{el}	4.3	4.1	4.7	4.0
Thermal time constant [min]	t_{th}	30	30	35	35
Moment of inertia rotor [kg-cm ²]	J	4.84E00	4.84E00	6.41E00	6.41E00
Weight of motor [kg]	m	6.4	6.4	7.75	7.75

Performance

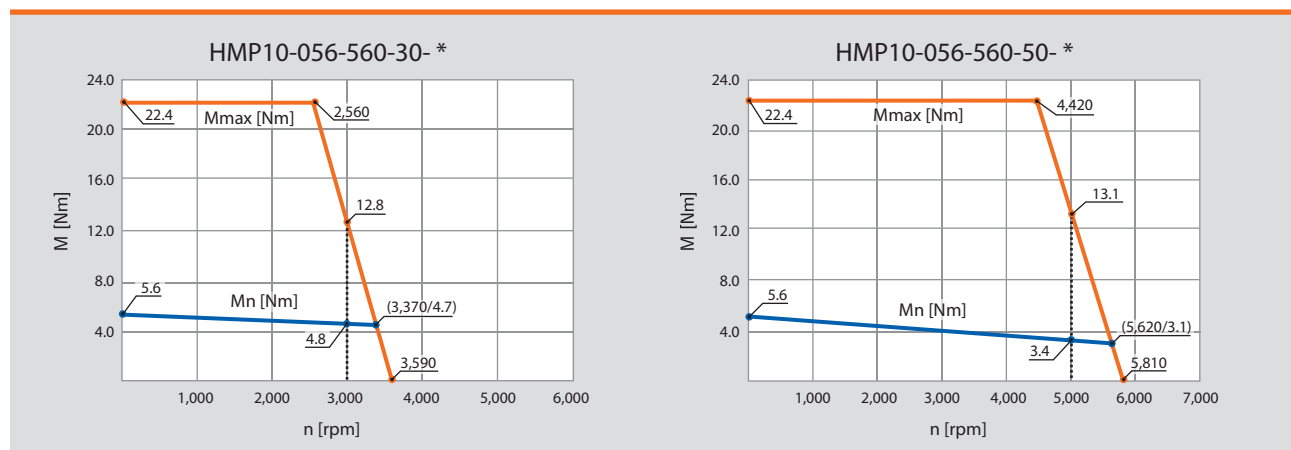

Dimensions

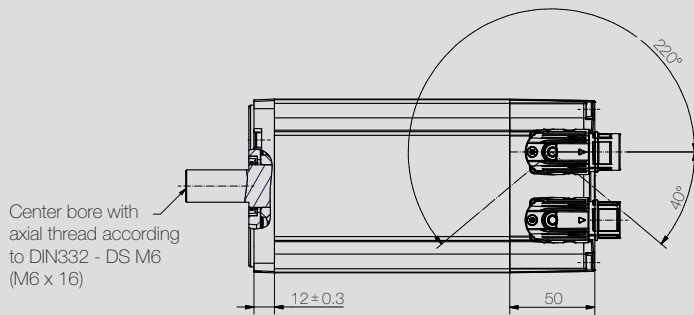
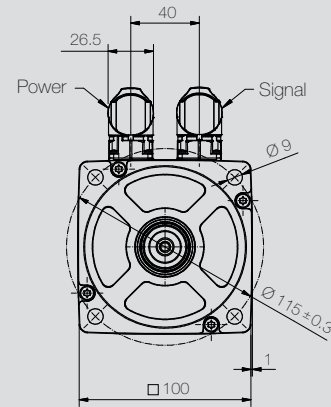
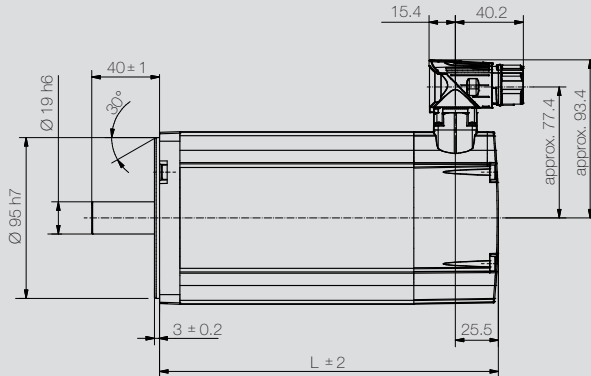

Feather key (option)

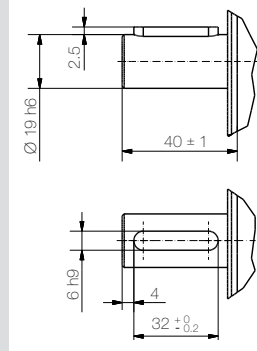

Motor model		L
HMP10-056	without brake	200 mm
HMP10-056	with brake	242 mm
HMP10-075	without brake	225 mm
HMP10-075	with brake	267 mm

HMP10

HMP10-075-560-30-*

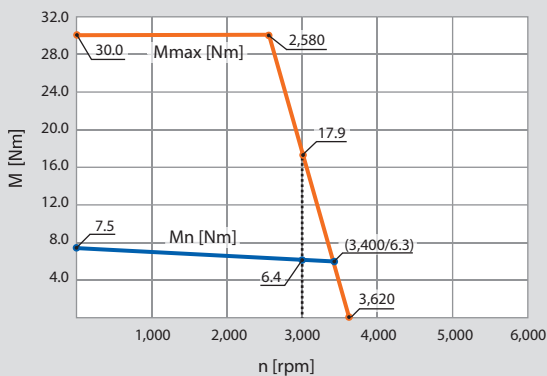

HMP10-075-560-50-*

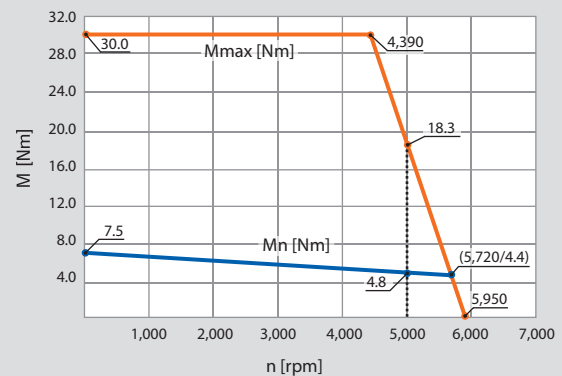

■ HMP13-055 / -091



Specifications

		HMP13-055				HMP13-091	
		2,000	3,600	2,000	3,600	2,000	3,600
Rated speed [rpm]	n_n	2,000	3,600	2,000	3,600	2,000	3,600
Number of pole pairs		3	3	3	3	3	3
Wiring of the motor winding		Y	Y	Y	Y	Y	Y
DC bus voltage [V _{DC}]	U_{bus}	320	320	560	560	560	560
Rated voltage motor [V _{rms}]	U_{mot}	178	175	317	307	315	310
Rated power [W]	P_n	1,000	1,500	1,000	1,500	1,500	2,250
Rated torque [Nm]	M_n	4.8	4.0	4.8	4.0	7.2	6.0
Rated current per phase [A _{rms}]	I_n	4.6	5.3	2.0	3.0	3.0	4.5
Stall torque [Nm]	M_0	5.5	5.5	5.5	5.5	9.1	9.1
Stall current per phase [A _{rms}]	I_0	4.1	7.1	2.2	4.1	3.8	6.7
Peak torque [Nm]	M_{max}	22.0	22.0	22.0	22.0	36.4	36.4
Peak current [A _{rms}]	I_{max}	19.0	32.8	10.8	18.8	17.6	30.8
Maximum speed [rpm]	n_{max}	2,480	4,220	2,340	4,310	2,440	4,150
Voltage constant at 1,000 rpm [V _{rms}]	k_e	85.2	50.1	157.1	85.2	150.4	85.9
Torque constant [Nm / A _{rms}]	k_t	1.34	0.77	2.5	1.34	2.56	1.36
Winding resistance (2 phases) at 20 °C [Ω]	R_{p-p}	3.5	1.1	10.7	3.5	6.1	1.9
Winding inductance (2 phases) [mH]	L_{p-p}	15.0	5.0	47.8	15.0	32.2	10.4
Electrical time constant [ms]	t_{el}	3.9	3.9	4.2	4.2	4.9	4.9
Thermal time constant [min]	t_{th}	35	35	35	35	42	42
Moment of inertia rotor [kg-cm ²]	J	9.82E00	9.82E00	9.82E00	9.82E00	1.40E01	1.40E01
Weight of motor [kg]	m	7.0	7.0	7.0	7.0	8.6	8.6

Performance

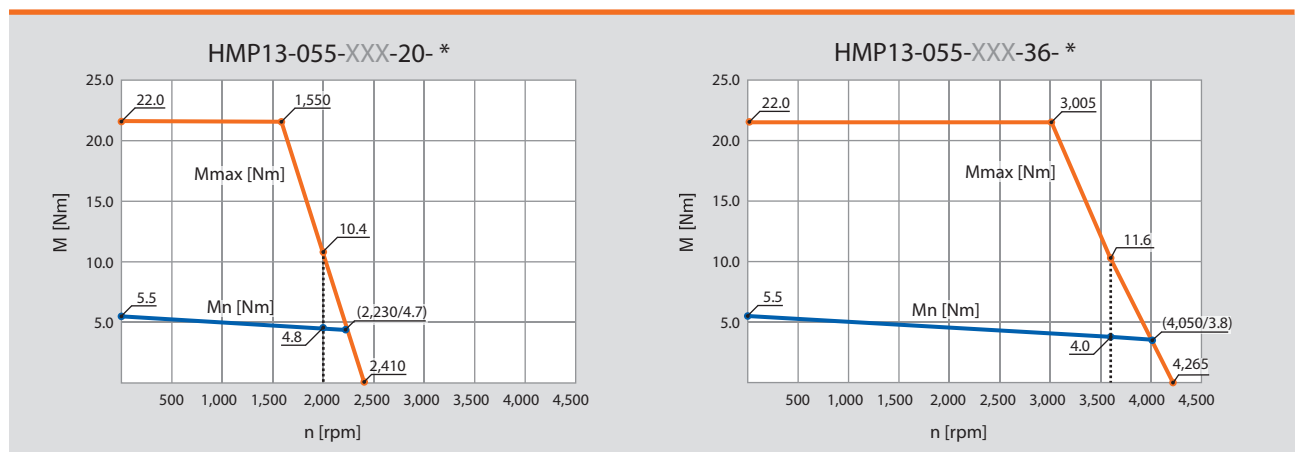

Dimensions

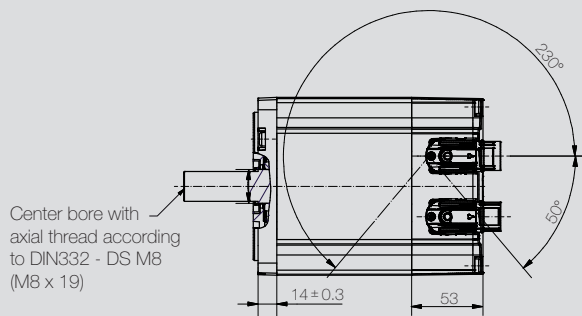
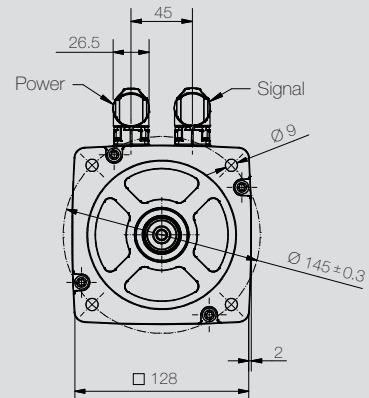
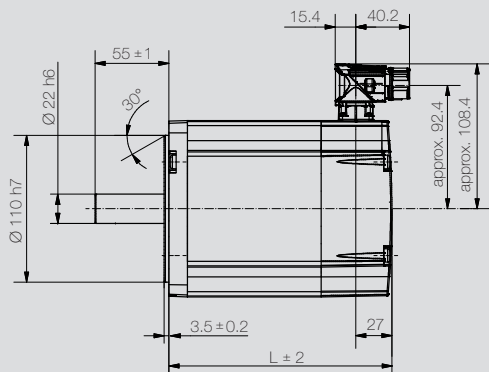

Feather key (option)

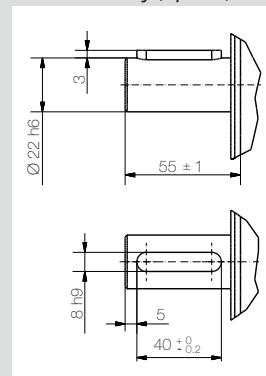

Motor model		L
HMP13-055	without brake	167 mm
HMP13-055	with brake	197 mm
HMP13-091	without brake	182 mm
HMP13-091	with brake	212 mm

HMP13

HMP13-091-560-20- *

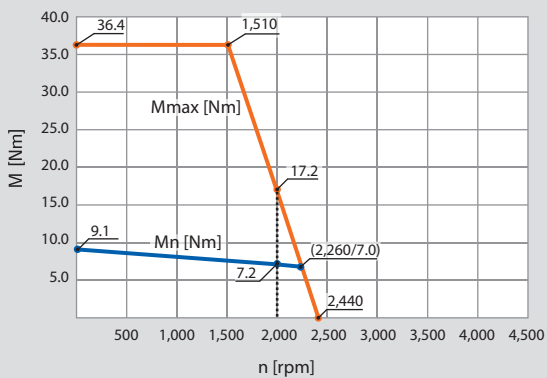

HMP13-091-560-36- *

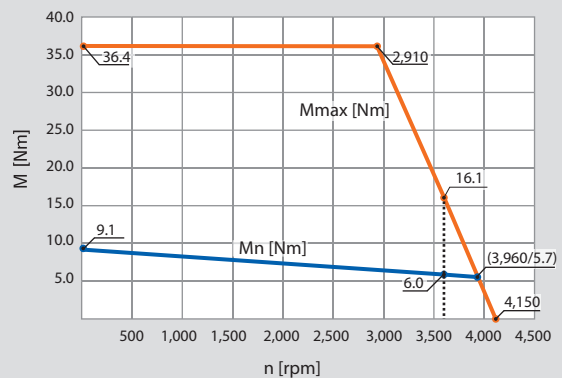

HMP13-123 / -185



Specifications

		HMP13-123		HMP13-185	
Rated speed [rpm]	n_n	2,000	3,600	2,000	3,600
Number of pole pairs		3	3	3	3
Wiring of the motor winding		Y	Y	Y	Y
DC bus voltage [V _{DC}]	U_{bus}	560	560	560	560
Rated voltage motor [V _{rms}]	U_{mot}	316	308	319	318
Rated power [W]	P_n	2,000	3,000	3,000	3,750
Rated torque [Nm]	M_n	9.6	8.0	14.4	10.0
Rated current per phase [A _{rms}]	I_n	3.8	6.2	6.0	7.2
Stall torque [Nm]	M_0	12.3	12.3	18.5	18.5
Stall current per phase [A _{rms}]	I_0	4.8	9.3	7.6	13.0
Peak torque [Nm]	M_{max}	49.2	49.2	74.0	74.0
Peak current [A _{rms}]	I_{max}	18.8	41.2	33.6	59.2
Maximum speed [rpm]	n_{max}	2,280	4,380	2,410	4,100
Voltage constant at 1,000 rpm [V _{rms}]	k_e	161.2	83.8	152.5	89.6
Torque constant [Nm / A _{rms}]	k_t	2.39	1.32	2.43	1.42
Winding resistance (2 phases) at 20 °C [Ω]	R_{p-p}	3.6	1.0	1.75	0.6
Winding inductance (2 phases) [mH]	L_{p-p}	21.2	6.6	13.2	4.2
Electrical time constant [ms]	t_{el}	5.4	5.4	5.4	5.4
Thermal time constant [min]	t_{th}	49	49	49	49
Moment of inertia rotor [kg-cm ²]	J	2.11E01	2.11E01	3.38E01	3.38E01
Weight of motor [kg]	m	10.7	10.7	14.8	14.8

Performance

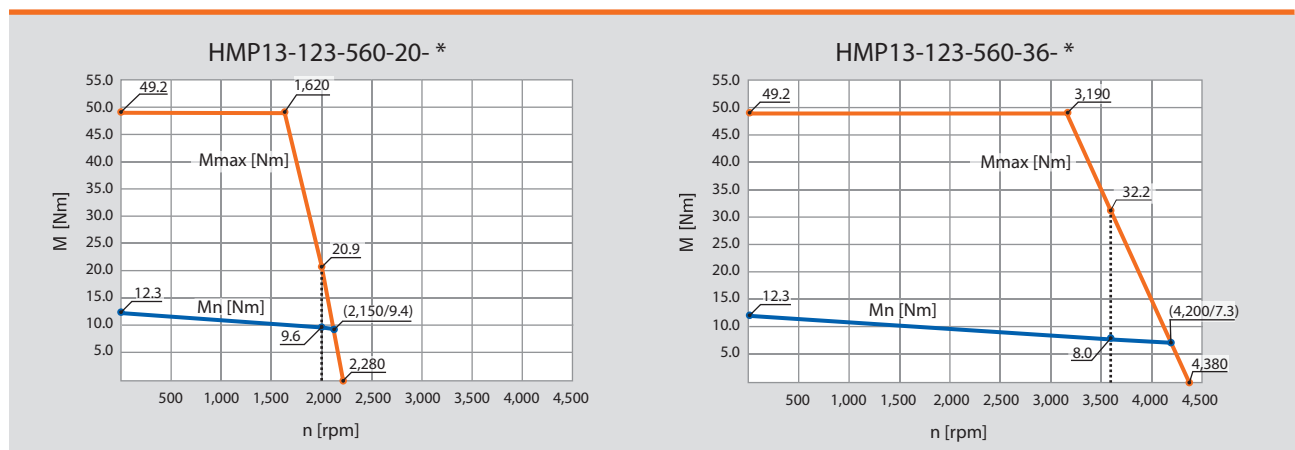

Dimensions

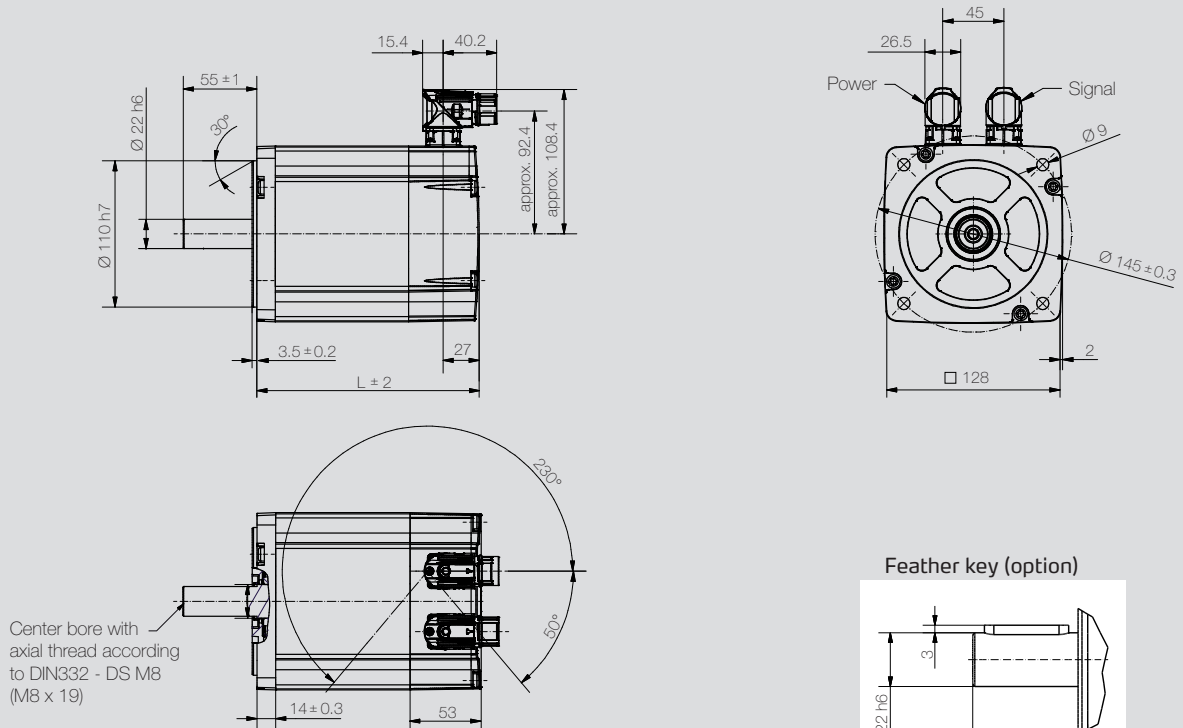

Motor model		L
HMP13-123	without brake	207 mm
HMP13-123	with brake	242 mm
HMP13-185	without brake	252 mm
HMP13-185	with brake	287 mm

Feather key (option)

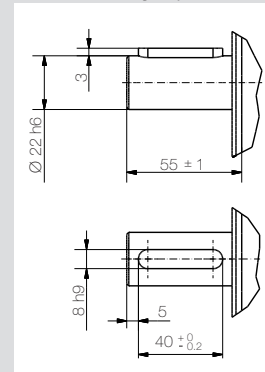

HMP13

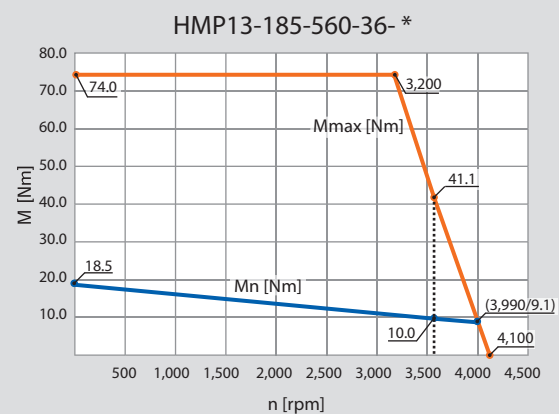
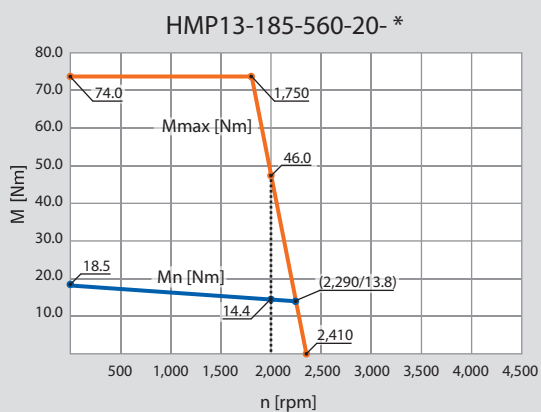

■ Configuration options

Feedback options

As standard, HeiMotion Premium motors are supplied with a resolver. As an option, various encoders with different interfaces can be mounted to the series.

Motor model	Resolver *	ECI 1118	EQI 1131	HS/M16
	Standard	EnDat 2.2	EnDat 2.2	
HMP04	X	X		X ¹⁾
HMP06	X	X	X	X
HMP08	X	X	X	X
HMP10	X	X	X	X
HMP13	X	X	X	X
	p. 30	p. 32		p. 31

* Safety enhanced version available to allow use of motors in applications up to cat. 3/PL d. acc. to EN ISO 13849-1 and SIL2 acc. to EN 62061/EN 61800-5-2

¹⁾ On request

Motor model	SEK/ SEL37	SKS/ SKM36*	SRS/ SRM50	EES/ EEM37	EKS/ EKM36*	EDS/ EDM35	HES/ HEM
	HIPERFACE®	HIPERFACE®	HIPERFACE®	HIPERFACE DSL®	HIPERFACE DSL®	HIPERFACE DSL®	hall encoder
HMP04	X						X
HMP06	X	X		X	X		X
HMP08	X	X	X	X	X	X	X
HMP10	X	X	X	X	X	X	X
HMP13	X	X	X	X	X	X	X
		p. 34		p. 36			p. 38

* Safety enhanced version available to allow use of motors in applications up to cat. 3/PL d. acc. to EN ISO 13849-1 and SIL2 acc. to EN 62061/EN 61800-5-2

Feedback system overview

Feedback device type	HCB	HCL
Resolver	X	
HIPERFACE® encoder	X	
HIPERFACE DSL® encoder	X	
Incremental encoder	X	X
SSI/BiSS	X	X (only SSI)
EnDat encoder	X	
	p. 50	p. 56

Connection options

Motor model	Y-Tec	2 x M23	I-Tec	1 x M23
HMP04	X			
HMP06	X	X	X	X
HMP08	X	X	X	X
HMP10	X	X	X	X
HMP13	X	X	X	X
	p. 42	p. 44	p. 46	p. 47

Standard connectors are rotatable; fixed connector orientation available upon request. Twintus and direct cable outlet available upon request.

Standard Resolver

Order Code: R1P

Specifications

RE-15

Number of pole pairs	1
Input frequency	10 kHz
Input voltage	7 V _{rms}
Current input	max. 50 mA
Transformation ratio	0.5 ± 10 %
Phase shift (nominal)	5° ± 3°
Ohmic resistance (at 25 °C)	
Stator winding	(at 20 °C) 67 ± 10 %
Rotor winding	(at 20 °C) 29 ± 10 %
Impedances	
Z _{ro} (no-load impedance rotor)	typ. 95 j 140
Z _{so} (no-load impedance stator)	typ. 130 j 250
Z _{ss} (short-circuit impedance stator)	typ. 115 j 215
Maximum residual voltage	30 mV
Accuracy	± 10'
Weight	86 g
Protection class	IP20
Insulation class	F
Insulation test housing / winding	500 V _{AC} / 50 Hz / 1 s
Moment of inertia rotor	15 g·cm ²
Order code	XXR1PXXXX



Environmental

Working environment	IE 32 according to EN 60721-3-3
Operating temperature	- 55 °C to 155 °C
Vibration according to EN 60068-2-6	100 m/s ² 10 - 150 Hz
Impact strength	400 m/s ² 6 ms
Maximum operating speed	20,000 rpm

Dimensions

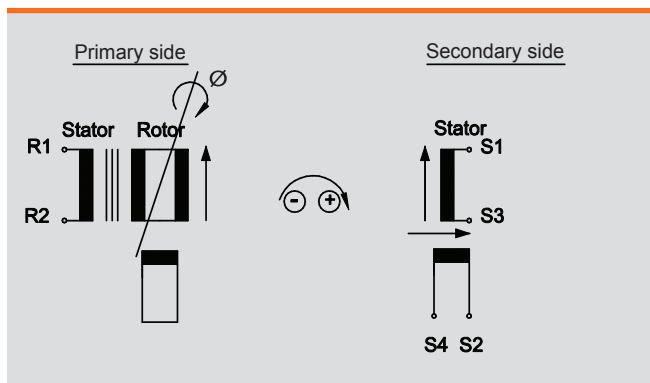

All specified rated motor values determined with resolver.

Safety norms

Safety Integrity Level	SIL 2 (EN 61800-5-2 / EN 62061)
Category	3 (EN ISO 13849-1)
Performance Level	PL d (EN ISO 13849-1)



SIL/PL
Capability

www.tuv.com
ID 0600000000

■ Absolute Encoder HS/M 16

Order Code S1S / B1M



Features:

- Integrated, compact dual encoder in the standard HeiMotion modular system
- Singleturn with SSI
- Multiturn with BiSS-C²⁾
- Speeds up to 12,000 min⁻¹
- Temperature evaluation via BiSS-C possible
- Electronic nameplate possible on request

Specifications	HS 16 (singleturn)	HM 16 (multiturn)
Supply voltage	5.0 V _{DC} +10/-5 %	5.0 V _{DC} +10/-5 %
Typical output current (without load)	120 mA	120 mA
Power consumption	0.6 W	0.6 W
Max. resolution singleturn	16 bit ¹⁾	16 bit ¹⁾
Max. number of absolute revolutions detected	-	12 bit (mechanical)
Data interface	SSI gray (RS422) + SinCos 1V _{pp}	BiSS-C (RS422) ²⁾ + SinCos 1V _{pp}
Sin/cos tracks	differential	differential
Number of sin/cos periods per revolution	256	256
Max. angular acceleration	100,000 rad/sec ²	100,000 rad/sec ²
Resistance to shocks (DIN EN 60068-2-27)	3,000 m/s ² (6 ms)	3,000 m/s ² (6 ms)
Resistance to vibration (DIN EN 60068-2-6)	300 m/s ²	300 m/s ²
Operating temperature	-40°C / +120°C	-40°C / +120°C
Storage temperature	-30°C / +80°C	-30°C / +80°C
Order code	XXS1SXXXX	XXB1MXXXX

¹⁾ 20 bit on request

²⁾ SSI gray on request

■ Options EnDAT® 2.2

Inductive sensing encoder EnDAT® 2.2

ECl1118

(Singleturn encoder)

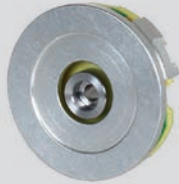

Specifications:

- Inductive encoder system without integral bearing
- Purely serial EnDAT® 2.2 interface
- For machines with high demands on dynamics and robustness
- High system accuracy
- Digital data transmission
- Electronic type plate

EnDat 2.2

EQI1131

(Multiturn encoder)



Specifications:

- Inductive encoder system without integral bearing
- Multiturn function via gearbox
- Purely serial EnDAT® 2.2 interface
- For machines with high demands on dynamics and robustness
- High system accuracy
- Digital data transmission
- Electronic type plate

EnDat 2.2

Specifications	ECl1118	EQI1131
Encoder type	inductive	inductive
Position values / revolution	262,144 18 bit	524,288 19 bit
Revolutions	-	4,096 12 bit
Calculation time t_{cal}	$\leq 6 \mu s$	$\leq 5 \mu s$
Clock frequency	$\leq 8 \text{ MHz}$	$\leq 16 \text{ MHz}$
System accuracy	$\pm 120''$	$\pm 120''$
Maximum operating temperature	+ 115 °C - 20 °C	+ 110 °C - 40 °C
Mechanically permissible speed	15,000 rpm	12,000 rpm
Voltage supply	3.6 - 14 V _{DC}	3.6 - 14 V _{DC}
Max. power consumption	520 - 600 mW	700 - 850 mW
Current consumption (typical) at 5 V	80 mA	115 mA
Multiturn	-	gearbox
Vibration 55 Hz to 2,000 Hz	$\leq 300 \text{ m/s}^2$	$\leq 400 \text{ m/s}^2$
Shock 6 ms	$\leq 1.000 \text{ m/s}^2$	$\leq 2.000 \text{ m/s}^2$
Digital interface	EnDAT® 2.2	EnDAT® 2.2
Order code	XXE1SXXXX	XXE1MXXXX

Options HIPERFACE®

Capacitive sensing encoder - HIPERFACE®

SEK / SEL37

(Single-/ Multiturn encoder)



Specifications:

- 16 sin/cos periods per revolution
- Absolute position with a resolution of 512 steps per revolution
- Measuring of 4,096 revolutions (multiturn)
- Programming of the position value
- HIPERFACE®-interface
- Electronic type label



Optical sensing encoder - HIPERFACE®

SKS / SKM36

(Single-/ Multiturn encoder)



Specifications:

- 128 sin/cos periods per revolution
- Absolute position with a revolution of 4,096 steps per revolution
- Measuring of 4,096 revolutions (multiturn)
- Programming of the position value
- HIPERFACE®-interface
- Electronic type label



SRS / SRM50

(Single-/ Multiturn encoder)



Specifications:

- 1,024 sin/cos periods per revolution
- Absolute position with a revolution of 32,768 steps per revolution
- Measuring of 4,096 revolutions (multiturn)
- Programming of the position value
- HIPERFACE®-interface
- Electronic type label



Specifications	SEK/SEL37	SKS/SKM36	SRS/SRM50
Number of sin/cos periods per revolution	16	128	1.024
Maximum number of turns	Single SEK 1 Multi SEL 4,096	Single SKS 1 Multi SKM 4,096	Single SRS 1 Multi SRM 4,096
Code type for absolute value	binary	binary	binary
Code sequence ¹⁾	ascending	ascending	ascending
Measuring step during interpolation of the sin/cos signals (for 12 bit)	20 arc seconds	2.5 arc seconds	0.3 arc seconds
Maximum sin/cos signals interpretation error, integral non-linearity	± 288 arc seconds	± 80 arc seconds	± 45 arc seconds
Non-linearity of a sin/cos period differential non-linearity	± 144 arc seconds ²⁾	± 40 arc seconds ²⁾	± 7 arc seconds ²⁾
Output frequency	-	0 ... 65 kHz	0 ... 200 kHz
Resistance to shocks	100 g / 10 ms	100 g / 6 ms	100 g / 10 ms
Resistance to vibration	50 g / 10...2,000 Hz	50 g / 10...2,000 Hz	50 g / 10...2,000 Hz
Operating voltage range	7...12 V	7...12 V	7...12 V
Recommended supply voltage	8 V	8 V	8 V
Maximum operating current without load	< 50 mA	60 mA	80 mA
Available memory area within EEPROM 2048 ³⁾	1,792 bytes	1,792 bytes	1,792 bytes
Interface signals Process data cable = SIN, REFSIN, COS, REFCOS Parameter channel = RS 485	analog, differential digital	analog, differential digital	analog, differential digital
Maximum working temperature		+ 115 °C - 40 °C	
Order code	XXH1SXXXX XXH1MXXXX	XXH2SXXXX XXH2MXXXX	XXH3SXXXX XXH3MXXXX

Encoder

Safety norms

SKS/SKM36S

Safety integrity level ⁴⁾	-	SIL2 (EN 61800-5-2 / EN 62061)	-
Category ⁴⁾	-	3 (EN ISO 13849-1)	-
Performance level ⁴⁾	-	PL d (EN ISO 13849-1)	-

1) For rotation of the shaft in clockwise direction when facing in the direction of "A"

2) In the nominal position ± 0.1 mm

3) When using the electronic nameplate in operative connection with numerical controls, consider the patent EP 425 912 B 2; use in operative connection with speed controllers is excluded from this rule.

4) Safety norms are only valid for motors with safely mounted encoders.

Options HIPERFACE DSL®

Capacitive sensing encoder - HIPERFACE DSL®

EES / EEM37

(Single- or Multiturn encoder)



Specifications:

- Absolute position with a resolution of 17 Bit
- Measuring of 4,096 revolutions (multiturn)
- Programming of the position value
- HIPERFACE DSL®-interface
- Electronic type label



Optical sensing encoder - HIPERFACE DSL®

EKS / EKM36

(Single- or Multiturn encoder)



Specifications:

- Absolute position with a resolution of 18 Bit
- Measuring of 4,096 revolutions (multiturn)
- Programming of the position value
- HIPERFACE DSL®-interface
- Electronic type label



EDS / EDM35

(Single- or Multiturn encoder)



Specifications:

- Optical motor feedback system
- Measuring of 4,096 revolutions (multiturn)
- Programming of the position value
- HIPERFACE DSL®-interface
- Electronic type label



Specifications	EES/EEM ₃₇	EKS/EKM ₃₆	EDS/EDM ₃₅
Maximum number of turns	Single EES 1 Multi EEM 4.096	Single EKS 1 Multi EKM 4.096	Single EDS 1 Multi EDM 4.096
Code type for absolute value	binary	binary	binary
Code sequence ¹⁾	ascending	ascending	ascending
System accuracy	± 160 arc seconds	± 120 arc seconds	± 25 arc seconds
Resistance to shocks	100 g / 6 ms	100 g / 6 ms	100 g / 6 ms
Resistance to vibration	50 g / 10...2,000 Hz	50 g / 10...2,000 Hz	50 g / 10...2,000 Hz (according to EN 60068-2-6)
Operating voltage range	7...12 V	7...12 V	7...12 V
Recommended supply voltage	-	8 V	-
Maximum operating current without load	150 mA	150 mA	150 mA
Available memory area within EEPROM 2048 ²⁾	8,192 byte	8,192 byte	8,192 byte
Resolution	17 bit	18 bit	24 bit
Maximum working temperature	+ 115 °C - 40 °C	+ 115 °C - 20 °C	+ 115 °C - 40 °C
Order code	××D1S×××× ××D1M××××	××D2S×××× ××D2M××××	××D3S×××× ××D3M××××

Encoder

Safety norms	EES/EEM ₃₇	EKS/EKM ₃₆₋₂	EDS/EDM ₃₅
Safety integrity level ³⁾	SIL2 (EN 61800-5-2 / EN 62061)	SIL2 (EN 61800-5-2 / EN 62061)	-
Category ³⁾	3 (EN ISO 13849-1)	3 (EN ISO 13849-1)	-
Performance level ³⁾	PL d (EN ISO 13849-1)	PL d (EN ISO 13849-1)	-

1) For rotation of the shaft in clockwise direction when facing in the direction of "A"

2) When using the electronic nameplate in operative connection with numerical controls, consider the patent EP 425 912 B 2; use in operative connection with speed controllers is excluded from this rule.

3) Safety norms are only valid for motors with safely mounted encoders.

Options

SSI / BiSS-C / Incremental Encoder

Absolute Encoder SSI / BiSS-C

HES1-002



Specifications:

- Singleturn encoder with a resolution of 12 bit (interpolated 14 bit)
- SSI interface differential and single-ended
- Differential sin/cos signals with 1.0 V_{p-p}

HEM1-001

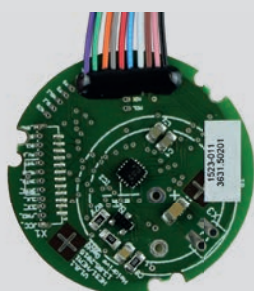

Specifications:

- Multiturn encoder with a resolution of 32 bit (≈ 4.2 billion revolutions measurable)
- Singleturn encoder with a resolution of 12 bit (interpolated 14 bit)
- SSI interface differential and single-ended
- Differential sin/cos signals with 1.0 V_{p-p}
- External battery connector

HEM1-002*



Specifications:

- Multiturn encoder with a resolution of up to 32 bit (≈ 4.2 billion revolutions measurable)
- Singleturn encoder with a resolution of 12 bit (interpolated 14 bit)
- BiSS interface differential and single-ended
- Differential sin/cos signals with 1.0 V_{p-p}
- Battery on board

Incremental Encoder

HES3



Specifications:

- Commutation and incremental signals ABZ, differential and single-ended

*Further information for your application upon request.

Specifications

(according to DIN 32878)

	HES1-002	HEM1-001	HEM1-002	HES3
Diameter (mm)	34.95 ± 0.05	34.95 ± 0.05	34.95 ± 0.05	34.95 ± 0.05
Power supply voltage	5.0 V _{DC} ± 10%	5.0 V _{DC} ± 10%	5.0 V _{DC} ± 10%	5.0 V _{DC} ± 10%
Maximum output current	50 mA	50 mA	50 mA	50 mA
Resolution singleturn	12 Bit 0,088°	12 Bit 0,088°	12 Bit 0,088°	13 Bit 0,044°
Number of turns	-	20 bit	20 bit	-
Backup battery for multiturn encoder	-	external	on board	-
SSI interface	differential & single ended gray coded	differential & single ended binary coded	differential & single ended binary coded	-
Maximum SSI operating frequency	4 MHz	4 MHz	4 MHz	-
Sin/cos signals	differential	differential	differential	-
Number of sin/cos periods per turn	1	1	1	-
Amplitude sin/cos	1.0 V _{p-p}	1.0 V _{p-p}	1.0 V _{p-p}	-
Incremental signals ABZ	-	-	-	differential
High-level output voltage ABZ	-	-	-	min. 2.8 V
Low-level output voltage ABZ	-	-	-	max. 0.4 V
Commutation signals	-	-	-	differential
Commutation high-level output voltage (U _W)	-	-	-	min. 2.8 V
Commutation low-level output voltage (U _W)	-	-	-	max. 0.4 V
Maximum working temperature	+ 125 °C - 30 °C			
Permissible relative humidity	15 to 85 % without condensation			
Order code segment	XXM2SXXXX	XXM1MXXXX	XXM2MXXXX	XXM1IXXXX

Encoder

■ Option Holding Brake

Every HeiMotion Premium motor can be equipped with a permanent-magnet DC holding brake.

Insulation class:	F (155 °C)
Maximum speed:	10,000 rpm
Voltage supply:	24 V _{DC} + 6 % / -10 %

Specifications brake	HMPo4		HMPo6		HMPo8	
	-002	-004	-007	-015	-028	-035
Moment of inertia motor <u>with</u> brake * [kg-cm ²]	5.50E-02	7.90E-02	3.19E-01	5.12E-01	1.68E00	2.20E00
Static braking torque min. at 20°C [Nm]	0.4	0.4	2.0	2.0	4.5	4.5
Dynamic braking torque at 20°C [Nm]	0.3	0.3	1.7	1.7	3.8	3.8
Rated input power at rated voltage and 20°C [W]	8	8	11	11	12	12
Working voltage [V _{DC}]	24	24	24	24	24	24
Input current brake [A]	0.33	0.33	0.46	0.46	0.50	0.50
Energy rating [kJ]	180	180	410	410	580	580
Separating time brake [ms]	≤10	≤10	≤40	≤40	≤38	≤38
Brake delay [ms]	≤2	≤2	≤3	≤3	≤3	≤3
Application delay time [ms]	≤6	≤6	≤15	≤15	≤20	≤20
Weight of motor <u>with</u> brake * [kg]	0.65	0.85	1.8	2.35	3.85	4.5
Slipping time ** [s]	0.5	0.5	0.5	0.5	0.5	0.5
Idle time ** [s]	0.5	0.5	0.5	0.5	0.5	0.5
Speed ** [min ⁻¹]	250	250	100	100	100	100
Cycle quantity ** [-]	5	5	5	5	5	5

Specifications brake	HMP10		HMP13			
	-056	-075	-055	-091	-123	-185
Moment of inertia motor <u>with</u> brake * [kg-cm ²]	5.63E00	7.20E00	1.05E01	1.48E01	2.31E01	3.58E01
Static braking torque min. at 20°C [Nm]	9.0	9.0	9.0	9.0	20	20
Dynamic braking torque at 20°C [Nm]	7.5	7.5	7.5	7.5	15	15
Rated input power at rated voltage and 20°C [W]	18	18	18	18	28	28
Working voltage [V _{DC}]	24	24	24	24	24	24
Input current brake [A]	0.75	0.75	0.75	0.75	1.17	1.17
Energy rating [kJ]	890	890	890	890	1,290	1,290
Separating time brake [ms]	≤70	≤70	≤70	≤70	≤90	≤90
Brake delay [ms]	≤3	≤3	≤3	≤3	3	3
Application delay time [ms]	≤30	≤30	≤30	≤30	≤35	≤35
Weight of motor <u>with</u> brake * [kg]	7.4	8.75	8.0	9.4	12.2	16.4
Slipping time ** [s]	0.5	0.5	0.5	0.5	0.5	0.5
Idle time ** [s]	0.5	0.5	0.5	0.5	0.5	0.5
Speed ** [min ⁻¹]	100	100	100	100	75	75
Cycle quantity ** [-]	5	5	5	5	5	5

* Incl. all attachment parts

** In order to ensure the optimum function of the brake at all times, it is recommended that the respective maintenance cycle (refreshment) be carried out when the brake is first put into operation and at four-week intervals.

The motor may not be operated with the brake applied. The brake is designed as a holding brake. An emergency stop of a running motor using the brake is permitted in exceptional cases. The number of emergency stops is limited by the moment of inertia of the entire system.

Option connector Y-Tec



Power		Signal Resolver	Signal HIPERFACE®	Signal SSI/BiSS	Signal EnDat 2.2		
Pin	Function	Pin	Function	Pin	Function		
A	U	1	cos +	1	cos +	1	-
B	V	2	cos - / refcos	2	cos - / refcos	2	-
C	W	3	sin +	3	sin +	3	-
Ground.	PE	4	sin- / refs sin	4	sin- / refs in	4	-
1	Therm. Prot. + ²⁾	5	R1 (ref +)	5	Data +	5	U _p
2	Therm. Prot. - ²⁾	6	R2 (ref -)	6	Data -	6	GND / 0 V
3	Brake + ¹⁾	7	-	7	U _s	7	Data +
4	Brake - ¹⁾	8	-	8	GND	8	Data -
5	-	9	Therm. Prot. + / Temp +	9	Therm. Prot. + / Temp +	9	CLK +
		10	Therm. Prot. - / Temp -	10	Therm. Prot. - / Temp -	10	CLK -
		11	-	11	-	11	Therm. Prot. +
		12	-	12	-	12	Therm. Prot. -

1) If applicable
2) Only with CKS 36, HES3 and HEM1-001

3) Battery + at HEM1-001
4) Battery - at HEM1-001

Motor connector

View mating face

<p>9-pole 9 x Ø 1 mm (3+PE+5)</p>	<p>12-pole 12 x Ø 1 mm</p>	<p>12-pole 12 x Ø 1 mm</p>	<p>12-pole 12 x Ø 1 mm</p>	<p>12-pole 12 x Ø 1 mm</p>
---------------------------------------	--------------------------------	--------------------------------	--------------------------------	--------------------------------

Mating connector

View mating face

<p>Intercontec type designation ESTA 202 NN00 34 0500 000 (Cable clamping range 10.5 - 12 mm)</p>	<p>Intercontec type designation ESTA 002 NN00 33 0001 000 (Cable clamping range 8.5 - 10.5 mm)</p>	<p>Intercontec type designation ESTA 002 NN00 33 0001 000 (Cable clamping range 8.5 - 10.5 mm)</p>	<p>Intercontec type designation ESTA 002 NN00 33 0001 000 (Cable clamping range 8.5 - 10.5 mm)</p>	<p>Intercontec type designation ESTA 002 NN00 33 0001 000 (Cable clamping range 8.5 - 10.5 mm)</p>
---	--	--	--	--

Signal Incremental

Pin	Function
1	Z
2	\bar{Z}
3	A
4	\bar{A}
5	B
6	\bar{B}
7	U (R)
8	\bar{U} (\bar{R})
9	V (S)
10	\bar{V} (\bar{S})
11	W (T)
12	\bar{W} (\bar{T})
A	$V_{CC} / 5 V$
B	GND
C	-



Mating connector with metal gland as shown or with plastic gland.

Motor connector Angled receptacle Y-Tec, rotatable

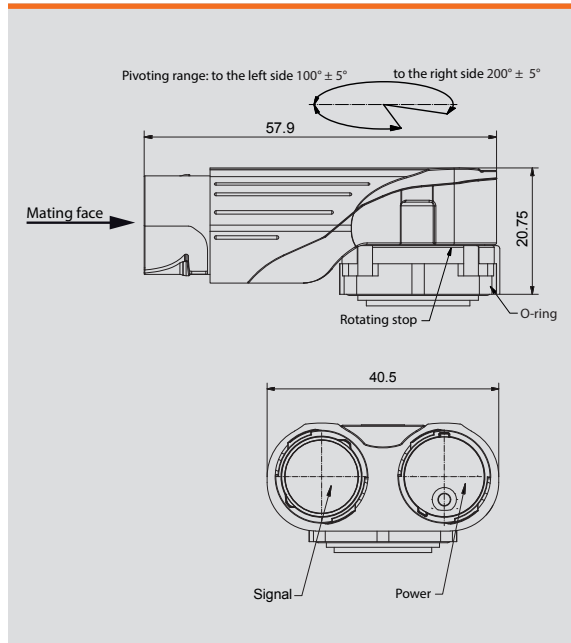

Connector

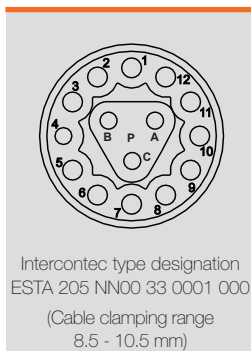

Mating connector

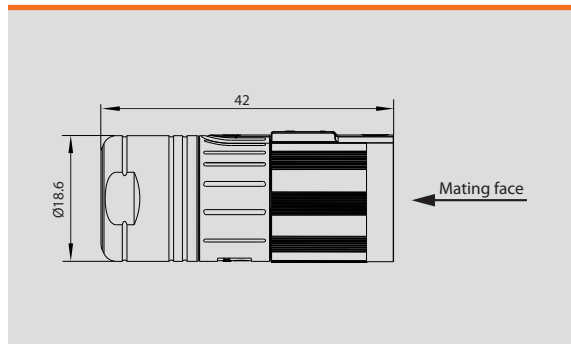

Option connector M23



Power		Signal Resolver	Signal HIPERFACE®	Signal SSI/BiSS	Signal EnDat 2.2
Pin	Function	Pin	Function	Pin	Function
A	Brake + ¹⁾	1	cos +	1	cos +
B	Brake - ¹⁾	2	cos - / refcos	2	cos - / refcos
C	Therm. Prot. +	3	sin +	3	sin +
D	Therm. Prot. -	4	sin - / refs sin	4	sin - / refs sin
1	U	5	-	5	V _{CC} / 5 V
4	V	6	R1 (ref +)	6	GND
3	W	7	R2 (ref -)	7	Data +
Ground.	PE	8	-	8	Data -
		9	-	9	CLK +
		10	-	10	CLK -
		11	Therm. Prot. + / Temp +	11	Data -
		12	Therm. Prot. - / Temp -	12	Therm. Prot. + / Temp +
				13	Therm. Prot. - / Temp -
				14	- ²⁾
				15	- ³⁾
				16	-
				17	-

1) If applicable
 2) Battery + at HEM1-001
 3) Battery - at HEM1-001

Motor connector

View mating face

8-pole 4 x Ø 2 mm (3+PE) + 4 x Ø 1 mm	12-pole 12 x Ø 1 mm, 0° coded	17-pole 17 x Ø 1 mm, 0° coded	17-pole 17 x Ø 1 mm, 0° coded	17-pole 17 x Ø 1 mm, 0° coded

Mating connector

View mating face

Intercontec type designation BSTA 078 NN00 42 0100 000 (Cable clamping range 9.5-14.5 mm)	Intercontec type designation ASTA 013 NN00 41 0100 000 (Cable clamping range 6-10 mm)	Intercontec type designation ASTA 014 NN00 41 0100 000 (Cable clamping range 6-10 mm)	Intercontec type designation ASTA 014 NN00 41 0100 000 (Cable clamping range 6-10 mm)	Intercontec type designation ASTA 014 NN00 41 0100 000 (Cable clamping range 6-10 mm)



Signal Incremental

Pin	Function
1	Z
2	\bar{Z}
3	A
4	\bar{A}
5	B
6	\bar{B}
7	U (R)
8	\bar{U} (\bar{R})
9	V (S)
10	\bar{V} (\bar{S})
11	W (T)
12	\bar{W} (\bar{T})
13	V _{CC} / 5 V
14	GND
15	Therm. Prot. +
16	Therm. Prot. -
17	-

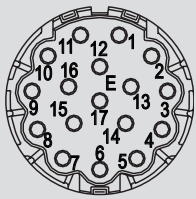

17-pole
17 x Ø 1 mm, 0° coded

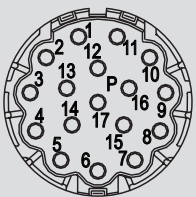

Intertec type designation
ASTA 014 NN00 41 0100 000
(Cable clamping range
6-10 mm)

Motor connector

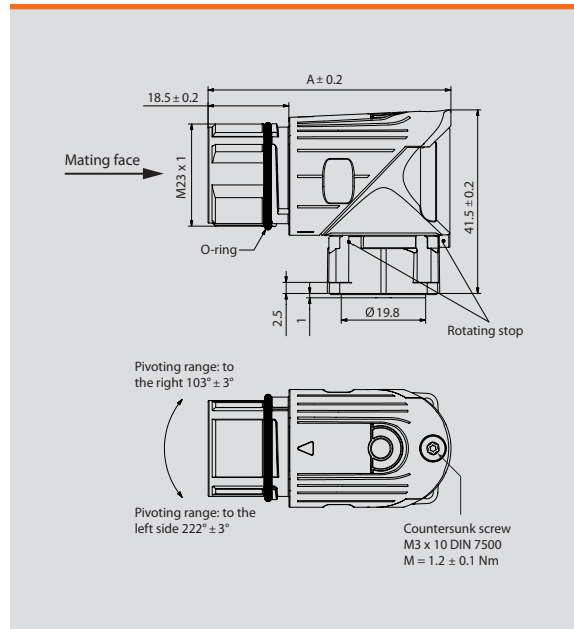

Mating connector

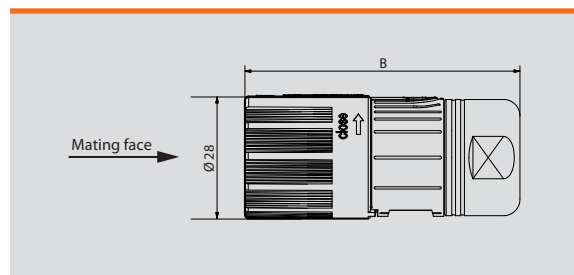

Connector type	A	B
Signal	55.6	59
Power	55.3	78

Connector

Option connectors for one cable solution

I-Tec connector



Power / Signal

Pin	Function
A	U
B	V
C	W
Grounding	PE
1	U _s (DSL +)
2	GND (DSL -)
3	Brake + *
4	Brake - *
5	-

Motor connector

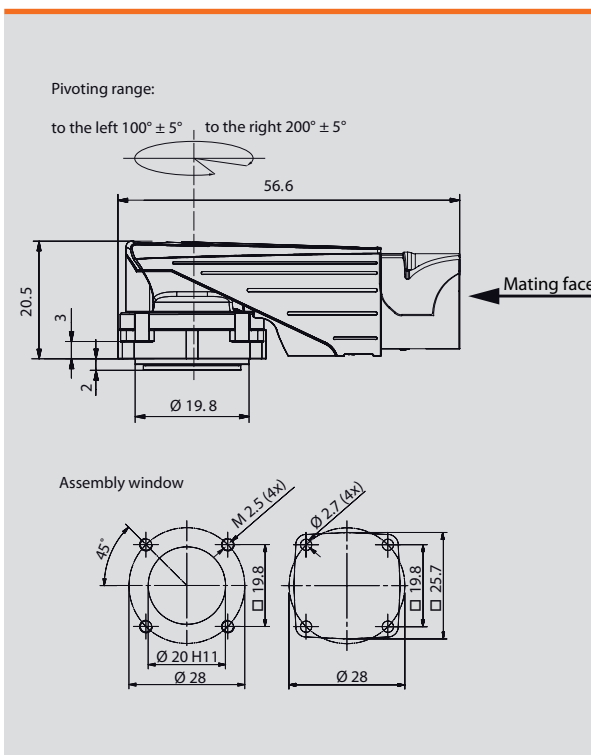

Motor connector



Mating connector

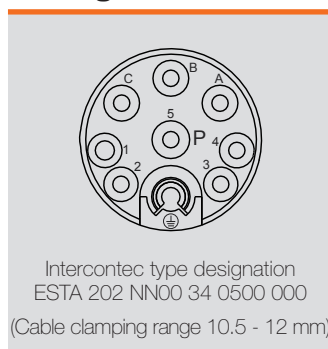

Mating connector

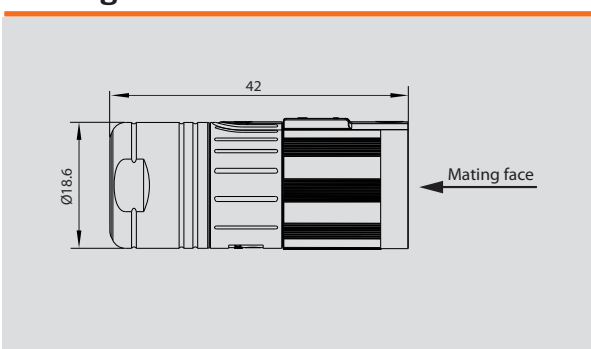

* If available

M23 connector



Power / Signal

Pin	Function
A	Brake + *
B	Brake - *
C	U _s (DSL+)
D	GND (DSL-)
1	U
4	V
3	W
Grounding	PE

Motor connector

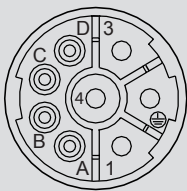

8-pole
4 x Ø 2mm (3+PE) + 4 x Ø 1mm

Mating connector

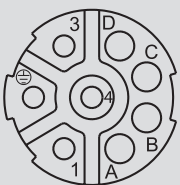

Intercontec type designation
BSTA 078 NN00 42 0100 000
(Cable clamping range 9.5 - 14.5 mm)

* If available

Motor connector

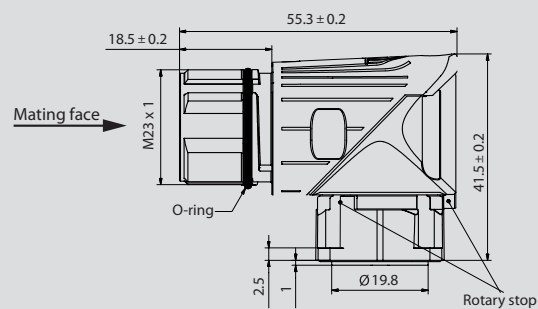

Pivoting range: to the right 103° ± 3°

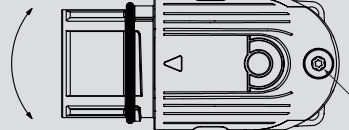

Pivoting range: to the left side 222° ± 3°

Countersunk screw
M3 x 10 DIN 7500
M = 1.2 ± 0.1 Nm

Connector

Mating connector

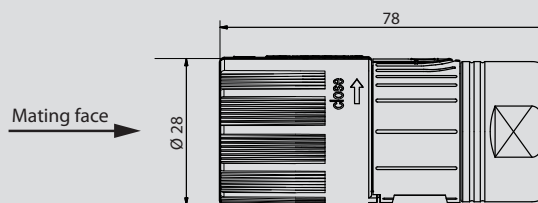

Option connectors for one cable solution

M23 H-Tec (hybrid) connector



Power / Signal

Pin	Function
A	U
B	V
C	W
D	-
Grounding	PE
7	Brake + *
8	Brake - *
H	U _s (DSL +)
L	GND (DSL -)

Motor connector

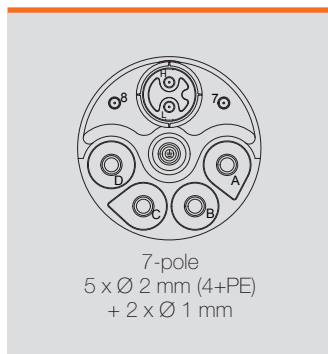

Mating connector

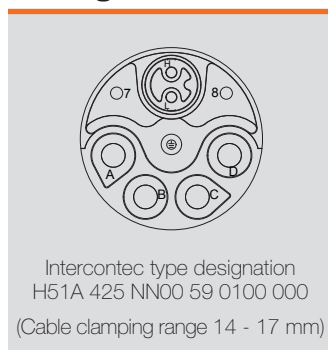

Motor connector

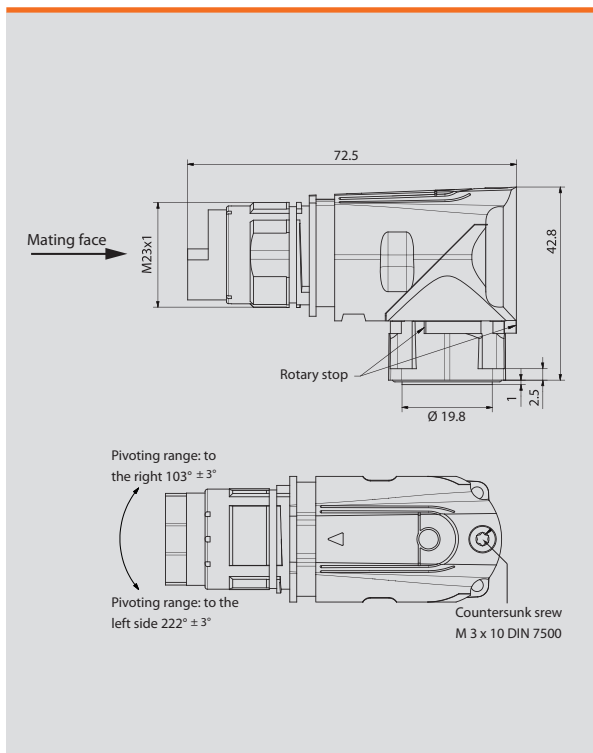

Mating connector

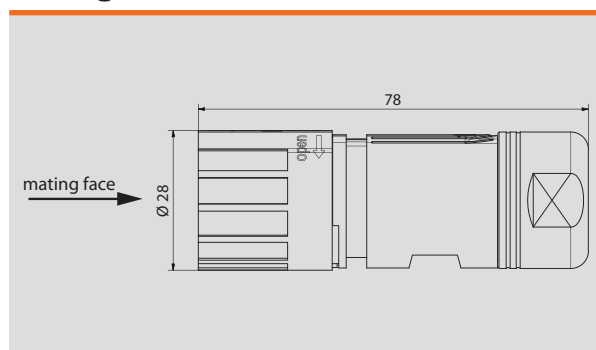

* If available

Servo drives

HCB servo drive - The compact

p. 50



The compact single-axis servo drives of the HCB series are true all-rounders in drive technology. They combine maximum power density with extensive motion control functions.

HCL Low Voltage Servo Drive

p. 56



In addition to the integrated controllers, the HCL servo controller series can be combined perfectly with our 24 V and 48 V motors of the HMD Next Generation series.

With a maximum current of up to 225 A peak, the controllers, in combination with our HMD servomotors, offer an ideal solution for demanding tasks.

■ HCB servo drive

General Information

The compact single-axis servo drives of the HCB-series are true all-rounders in drive technology. They combine maximum power density with extensive motion control functions. The HCB-series consists of two sizes, which are divided into two power stages for the 1-phase units and three power stages for the 3-phase units.



All proven fieldbus interfaces are “on board” – from CANopen® to EtherCAT® to PROFINET®, which promise problem-free communication. Its versatility is further underlined by the numerous encoder interfaces, also for single-cable solutions. Complex positioning tasks through linked position sets can be interconnected. The position-synchronous or speed-synchronous motion of various drives with variable gear ratios can be quickly parameterised via the software assistant. Rotary table applications, position triggers, rotor position triggers or switching cams – a wide range of dynamic application tasks can be handled via the integrated software functions.

In combination with the HeiMotion servo motors with encoder variant matched to your application and a gearbox from the HMPG series mounted in the gearbox direct attachment, you get a customized drive axis from a single source at an unbeatable price-performance ratio.

■ Connections / Inputs and Outputs

Connection	Function
X1	I/O communication
X2A	Resolver connection
X2B	Multi-encoder connection
X3	STO interface (STOA, STOB), limit switch (DIN6, DIN7) Dig. output (DOUT0)
X4	CANopen®
X6	Motor connection
X6A	Motor brake / HIPERFACE DSL® (HCB 3-phase)
X9	Voltage supply
X9A	Brake resistor (HCB 3-phase)
X9B	24V supply (HCB 3-phase)
X18	Ethernet interface
X19	USB interfae
X21	Realtime Ethernet interface

■ General Properties

Ambient Conditions

Ambient temperature in operation:	0 °C to +40 °C +40 °C to +50 °C with power reduction 2.5 % / K
Storage temperature:	-25 °C to +70 °C
Operating and storage humidity:	Relative humidity 90 % (without condensation)
Protection class:	IP20
Installation altitude:	Mounting height max. 2000 m above sea level, above 1000 m above sea level with power reduction 1 % per 100 m
Degree of pollution:	2
Type of installation	Installation in switch cabinet with at least protection class IP54

Functions*

- Safety function "Safe Torque Off" (STO)
- Realization of functionality SS1 possible
- Switching cams
- Direct control of the holding brake in the motor
- Automatic determination of motor parameters
- Position set-dependent synchronization possible
- Path program / linking
- Integrated position control
- Parameterizable belt locks

* Some functions are not available for all models.

Power cable

Length	Heidrive-No.
3 m	14-007-051-18-0
5 m	14-007-051-19-0
10 m	14-007-051-23-0

Signal cable (resolver)

Length	Heidrive-No.
3 m	14-007-051-60-0
5 m	14-007-051-62-0
10 m	14-007-051-67-0

Signal cable (HIPERFACE®)

Length	Heidrive-No.
3 m	14-007-051-78-0
5 m	14-007-051-80-0
10 m	14-007-051-85-0

■ HCB Servo Drive

Single-phase

■ Specifications

	HCB 2/6-1	HCB 4/12-1	HCB 8/24-1
Voltage supply	230 V _{AC} [± 10 %], 50...60 Hz		
Control voltage	24 V _{DC} [± 20 %] (0.35 A)		
DC link voltage	325 V _{DC} (with U _{mains} = 230 V _{AC})		
Output power	400 W	800 W	1.6 kW
Max. output power for 2 s	1 kW	2 kW	4.8 kW
Rated output current	2 A _{rms}	4 A _{rms}	8 A _{rms}
Max. output current for 2 s	6 A _{rms}	12 A _{rms}	24 A _{rms}
Internal brake resistor	75 Ω		30 Ω
Continuous power / pulse power	bis 2 kW		6.4 kW
External brake resistor	75 Ω, max. 2 kW		≥ 30 Ω
Holding brake	24 V _{DC} , max. 2 A		
Dimensions servo drive H x W x D	200 x 50 x 163 mm 245 x 50 x 163 mm with mounting plate		230 x 67 x 200 mm 275 x 67 x 200 mm with mounting plate
Weight	1.5 kg		2.9 kg
Encoder evaluation	EnDAT® 2.2, HIPERFACE®, HIPERFACE DSL®, resolver, analog and digital incremental encoders with/without commutation signals, BiSS (Type C)		
Interfaces	USB 2.0, Ethernet, CAN bus, EtherCAT®, PROFINET®, MicroSD card		
Inputs / outputs	8 x digital in (24 V _{DC}), 2 x analog in (± 10 V) 3 x digital out (24 V _{DC})		
Product numbers	12-225-020-01-0	12-225-020-02-0	12-225-020-03-0

Dimensional Drawing HCB 2/6-1 and HCB 4/12-1

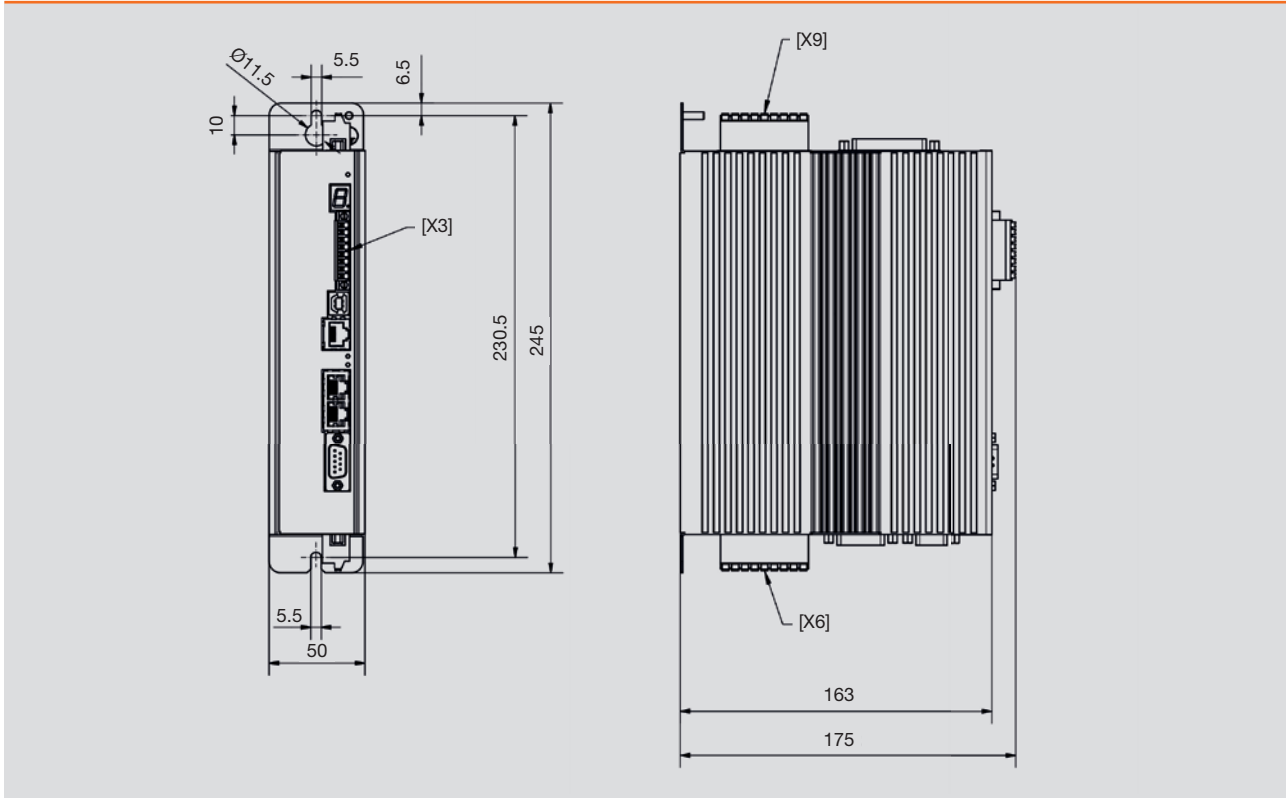

Dimensional Drawing HCB 8/24-1

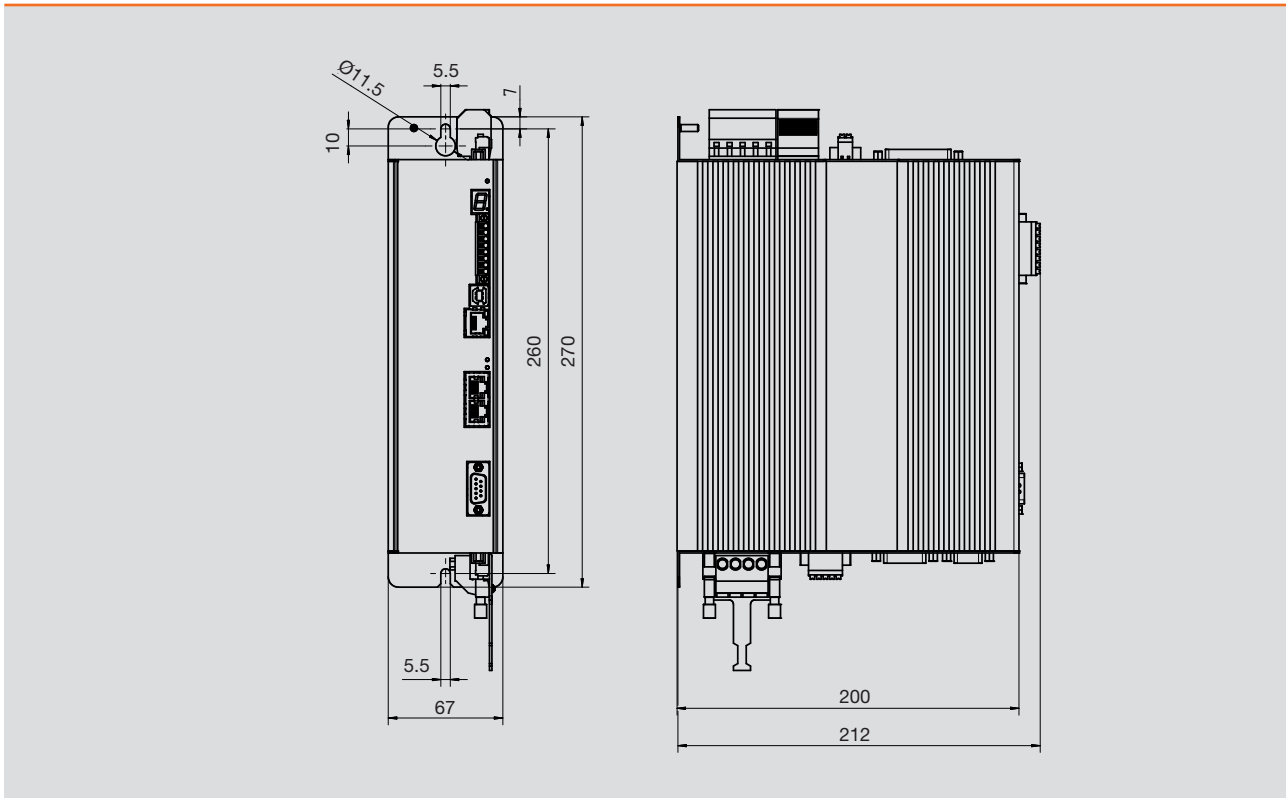

■ HCB Servo Drive

Three-phase

■ Specifications

	HCB 4/12-3	HCB 8/24-3	HCB 12/30-3	HCB 20/50-3	HCB 40/100-3
Voltage supply	3 x 230...480 V _{AC} [± 10 %], 45...66 Hz				
Control voltage	24 V _{DC} [± 20 %] (0.35 A)	24 V _{DC} [± 20 %] (0.45 A)	24 V _{DC} [± 20 %] (0.65 A)	24 V _{DC} [± 20 %] (max. 1 A)	
DC link voltage	565 V _{DC} (with U _{mains} = 400 V _{AC})				
Output power	1.6 kW	3.2 kW	4.8 kW	8 kW	16 kW
Max. output power for 2 s	4.8 kW	9.6 kW	12 kW	20 kW	40 kW
Rated output current	4 A _{rms}	8 A _{rms}	12 A _{rms}	20 A _{rms}	40 A _{rms}
Max. output current for 2s	12 A _{rms}	24 A _{rms}	30 A _{rms}	50 A _{rms}	100 A _{rms}
Internal brake resistor	30 Ω				15 Ω
Continuous power / pulse power	50 W to 24 kW			80 W	160 W
External brake resistor	≥ 30 Ω			15 Ω ≤ R _{ex} ≤ 50 Ω	15 Ω ≤ R _{ex} ≤ 50 Ω
Holding brake	24 V _{DC} , max. 2A				
Dimensions servo drive H x W x D	230 x 67 x 200 mm 275 x 67 x 200 mm with mounting plate			351 x 90.5 x 256.5 mm 390 x 93 x 263 mm with mounting plate	351 x 162.5 x 256.5 mm 390 x 165 x 263 mm with mounting plate
Weight	2,9 kg		8,0 kg		13,5 kg
Encoder evaluation	EnDAT® 2.2, HIPERFACE®, HIPERFACE DSL®, resolver, analog and digital incremental encoders with/without commutation signals, BiSS (Type C)				
Interfaces	USB 2.0, Ethernet, CAN, EtherCAT®, PROFINET®, MicroSD card			USB 2.0, Ethernet, CAN, EtherCAT®, PROFINET®, MicroSD card, Ethernet Powerlink*	USB 2.0, Ethernet, CAN, EtherCAT®, PROFINET®, MicroSD card, Ethernet Powerlink*
Inputs / outputs	8 x digital in (24 V _{DC}), 2 x analog in (± 10 V) 3 x digital out (24 V _{DC})				
Product numbers	12-405-020-11-0	12-405-020-12-0	12-405-020-13-0	12-405-020-14-0	12-405-020-15-0

* On request.

Dimensional Drawing HCB 4/12-3, HCB 8/24-3, HCB 12/30-3

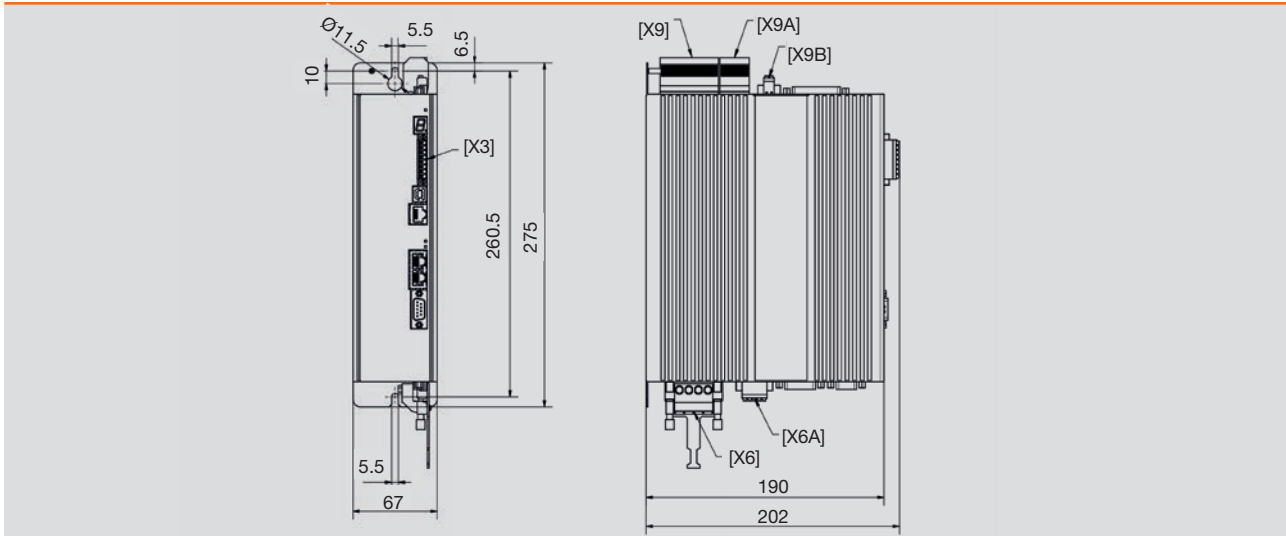

Dimensional Drawing HCB 20/50-3

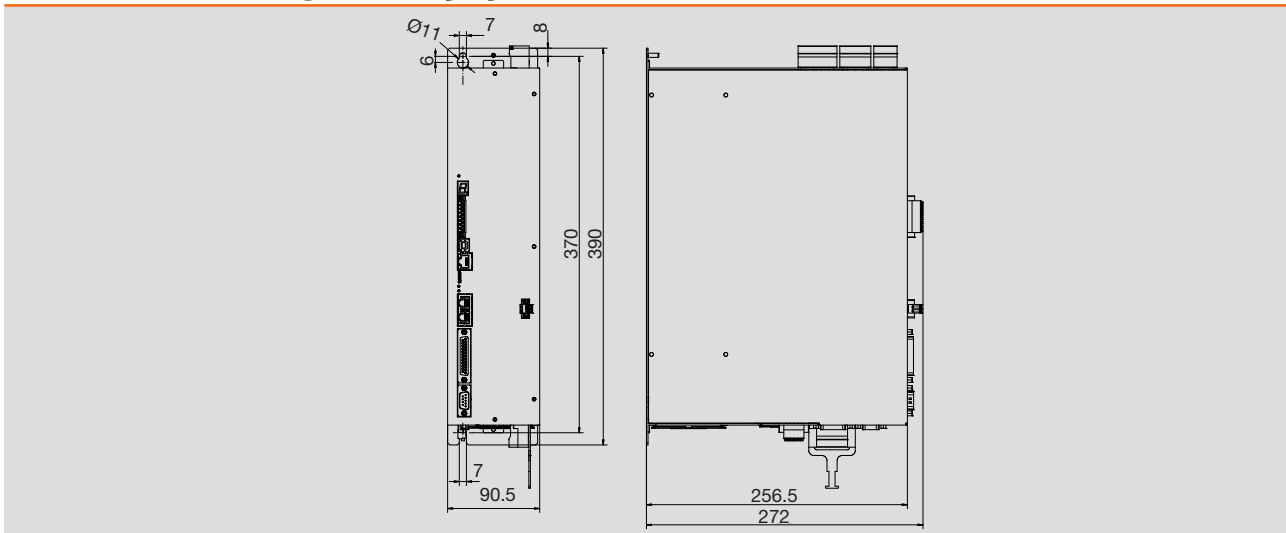

Dimensional Drawing HCB 40/100-3

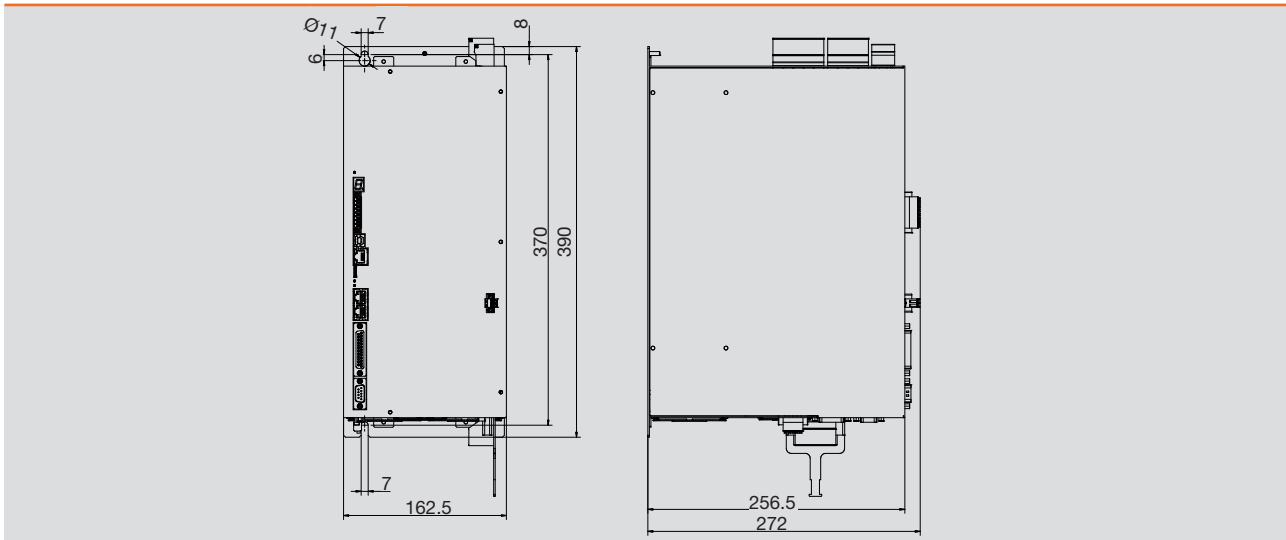

■ HCL Servo Drive

■ Introduction

In addition to the integrated controllers, the HCL servo controller series perfectly can be combined perfectly with our 24 V and 48 V motors of the HMD Next Generation series.

With a maximum current of up to 225 A peak, the controllers, in combination with our HMD servo-motors, offer an ideal solution for demanding tasks.

This solution delivers an extremely cost-efficient package that includes a certified STO interface and UL recognition.

Thanks to their freely programmable Motion Process Unit (MPU), the controllers are ideal for simple control tasks. An additional PLC is often not required. EtherCAT® or CANopen® are two of the most common and proven fieldbuses available for use with an external PLC.

■ Sizes



Ambient Conditions

Protection class	IP20 except clamps (IP00)
Accident prevention regulation	In conformity with local regulations (in Germany e. g. DGUV regulation 3)
Mounting method	Installation only for vertical mounting into a switch cabinet with protection class at least IP4x, if using the safety function STO at least IP54

Functions

- "Safe Torque Off (STO)" safety function
- Device status display via three LEDs
- Freely programmable MPU (**M**otion **P**rocess **U**nit)
 - simple PLC functionality
- Compact 4-quadrant controller
- Vector controlled
- Galvanically isolated fieldbus interfaces

Accessories

HCL stick – USB/CAN program interface

The HCL stick connects the HCL CAN controller to your Windows® computer via its USB interface. This makes it easy to commission, parameterize and program the controller using the software tools that we provide for the controllers.

HCL brake – brake chopper for mains-powered systems

The HCL brake chopper effectively cuts overvoltages and redirects braking energy to an external load resistor. To protect all components in the DC link, the overvoltage threshold can be set using a DIP switch. The maximum peak braking current is 55 A when an external 1 Ohm load resistor is connected (not included in the scope of delivery).

■ HCL Servo Drive

60 C

Specifications

	HCL 60 C
Electronic supply voltage U_e	18 - 30 V
Power supply voltage U_p	9 - 60 V
Maximal output current	42.5 A _{rms}
Continuous output current (UL/CE) ≤ 24 V	14.5 A _{rms}
Continuous output current (UL/CE) ≤ 60 V	9.5 A _{rms}
PWM frequency	32 KHz
PWM mode	SVPWM
Motor types	Brushless motors, linear motors
STO	Yes
Security integrity level (SIL)	SIL 3
Performance level (PL)	PL e
Fieldbus	CAN
Galvanically isolated	No
CAN protocol	DS301
Encoder supply	5 V / 0.2 A
Encoder evaluation	SSI / incremental encoder / BiSS
Number of inputs / outputs	6 digital IN / 3 digital OUT / 1 analog IN
Size	78 x 74 x 29 mm
Assembly	Wall mounted
Installation requirements	IP54
Maximum operating ambient temperature	-40 °C to 55 °C

Dimensional Drawing

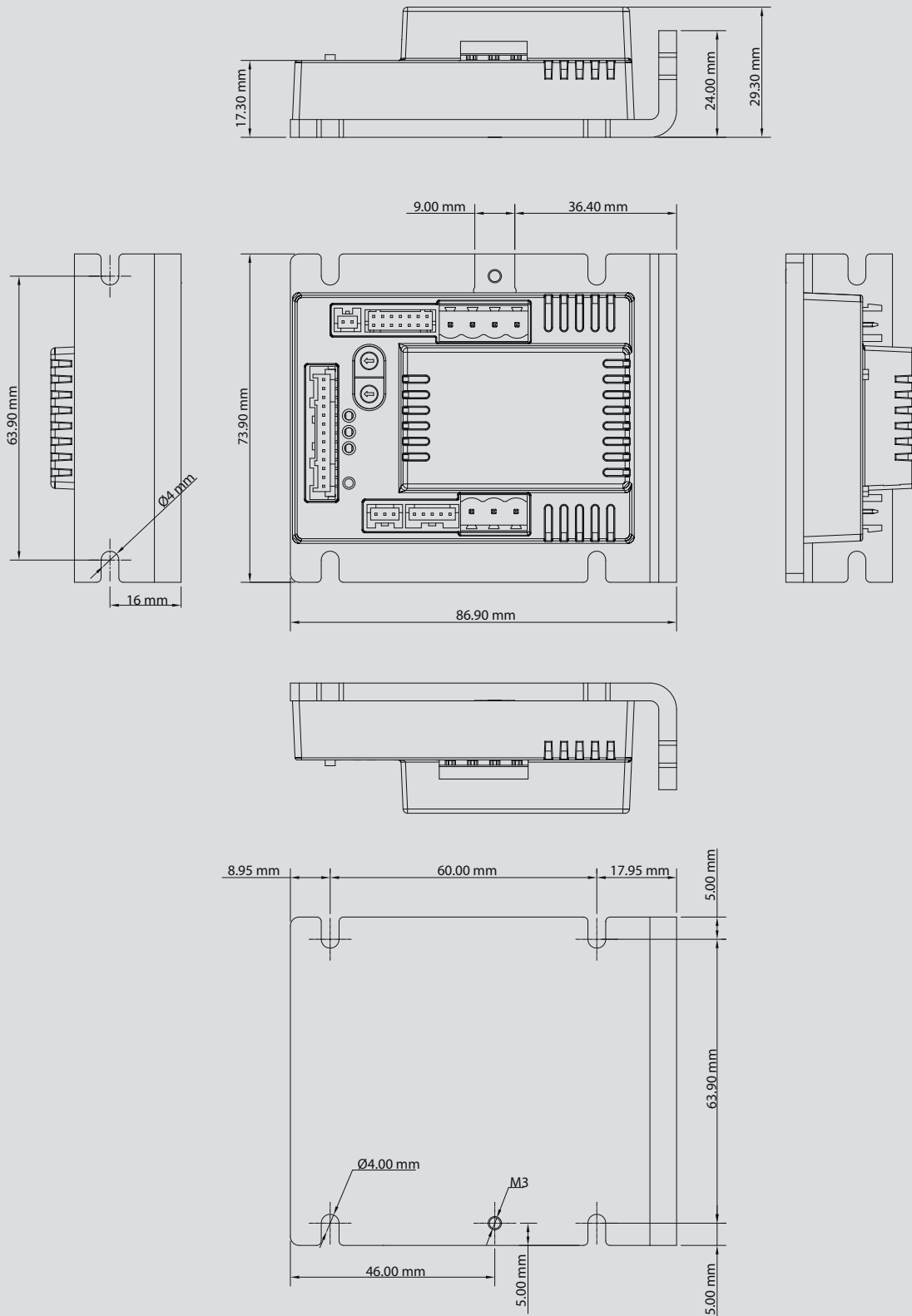

■ HCL Servo Drive

120 C / E

Specifications	HCL 120 C	HCL 120 E
Electronic supply voltage U_e	18 - 30 V	
Power supply voltage U_p	9 - 60 V	
Maximal output current	85 A _{rms}	
Continuous output current (UL/CE) ≤ 24 V	-	
Continuous output current (UL/CE) ≤ 60 V	18.5 A _{rms}	
PWM frequency	32 KHz	
PWM mode	SVPWM	
Motor types	Brushless motors, linear motors	
STO	Yes	
Security integrity level (SIL)	SIL 3	
Performance level (PL)	PL e	
Fieldbus	CAN	EtherCAT®
Galvanically isolated	No	Yes
CAN protocol	DS301	
Encoder supply	5 V / 0.2 A	
Encoder evaluation	SSI / incremental encoder / BiSS	
Number of inputs / outputs	6 digital IN / 3 digital OUT / 1 analog IN	
Size	87 x 74 x 29 mm	87 x 74 x 49 mm
Assembly	Wall mounted	
Installation requirements	IP54	
Maximum operating ambient temperature	-40 °C to 55 °C	

Dimensional Drawing HCL 120 C

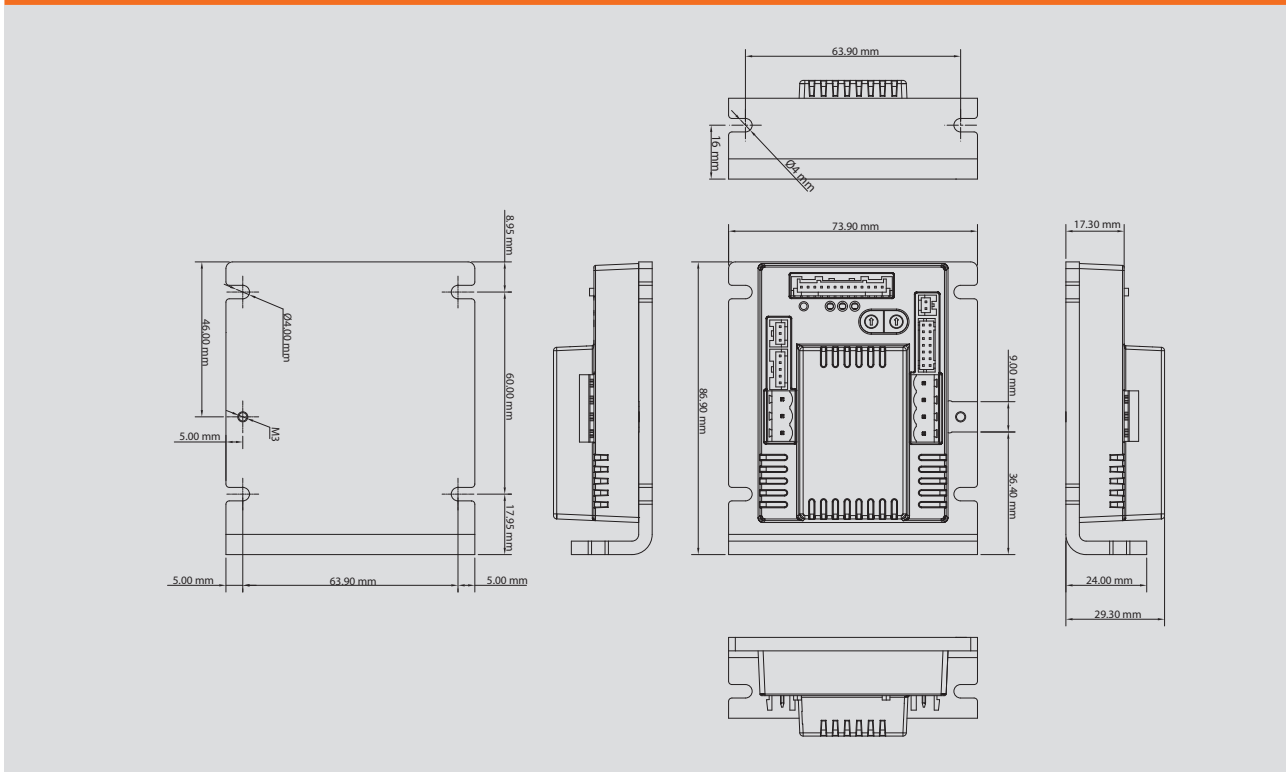

Dimensional Drawing HCL 120 E

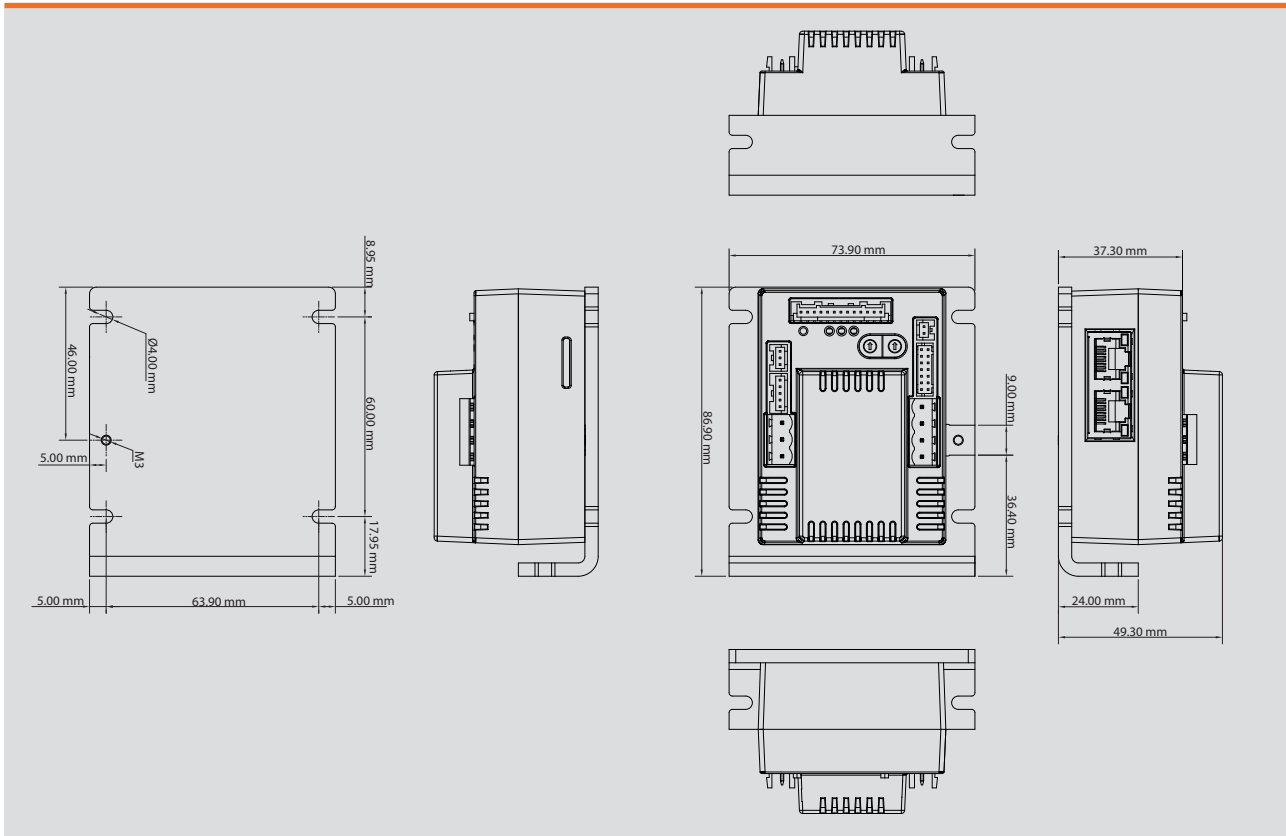

■ HCL Servo Drive

225 CS

Specifications

	HCL 225 CS
Electronic supply voltage U_e	9 - 30 V
Power supply voltage U_p	9 - 60 V
Maximal output current	159 A _{rms}
Continuous output current (UL/CE) ≤ 24 V	54.5 A _{rms}
Continuous output current (UL/CE) ≤ 60 V	46 A _{rms}
PWM frequency	32 KHz
PWM mode	SVPWM
Motor types	Brushless motors, linear motors
STO	Yes
Security integrity level (SIL)	SIL 3
Performance level (PL)	PL e
Fieldbus	CAN
Galvanically isolated	Yes
CAN protocol	DS301
Encoder supply	5 V / 0.2 A
Encoder evaluation	SSI / incremental encoder / BiSS
Number of inputs / outputs	6 digital IN / 3 digital OUT / 2 analog IN
Size	111 x 100 x 56 mm
Assembly	Wall
Installation requirements	IP54
Maximum operating ambient temperature	-40 °C to 40 °C

Dimensional Drawing

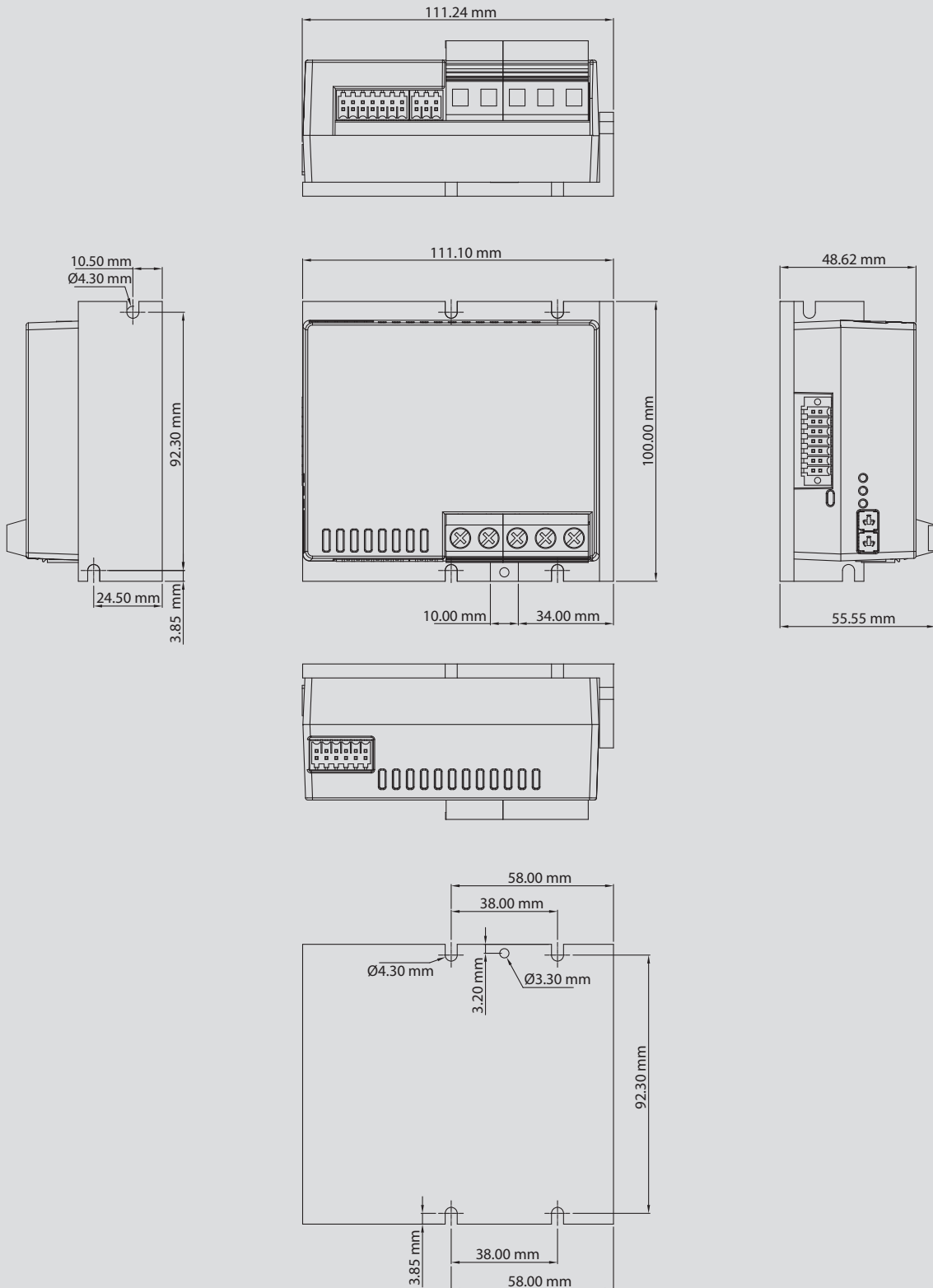

■ HCL Servo Drive

225 C / E

Specifications

	HCL 225 C	HCL 225 E
Electronic supply voltage U_e	9 - 30 V	
Power supply voltage U_p	9 - 60 V	
Maximal output current	159 A _{rms}	
Continuous output current (UL/CE) ≤ 24 V	54.5 A _{rms}	
Continuous output current (UL/CE) ≤ 60 V	46 A _{rms}	
PWM frequency	32 KHz	
PWM mode	SVPWM	
Motor types	Brushless motors, linear motors	
STO	Yes	
Security integrity level (SIL)	SIL 3	
Performance level (PL)	PL e	
Fieldbus	CAN	EtherCAT®
Galvanically isolated	Yes	
CAN protocol	DS301	
Encoder supply	5 V / 0.2 A	
Encoder evaluation	SSI / incremental encoder / BiSS	
Number of inputs / outputs	6 digital IN / 3 digital OUT / 2 analog IN	
Size	111 x 100 x 39 mm	78 x 74 x 29 mm
Assembly	Wall mounted	
Installation requirements	IP54	
Maximum operating ambient temperature	-40 °C to 40 °C	

Dimensional Drawing HCL 225 C

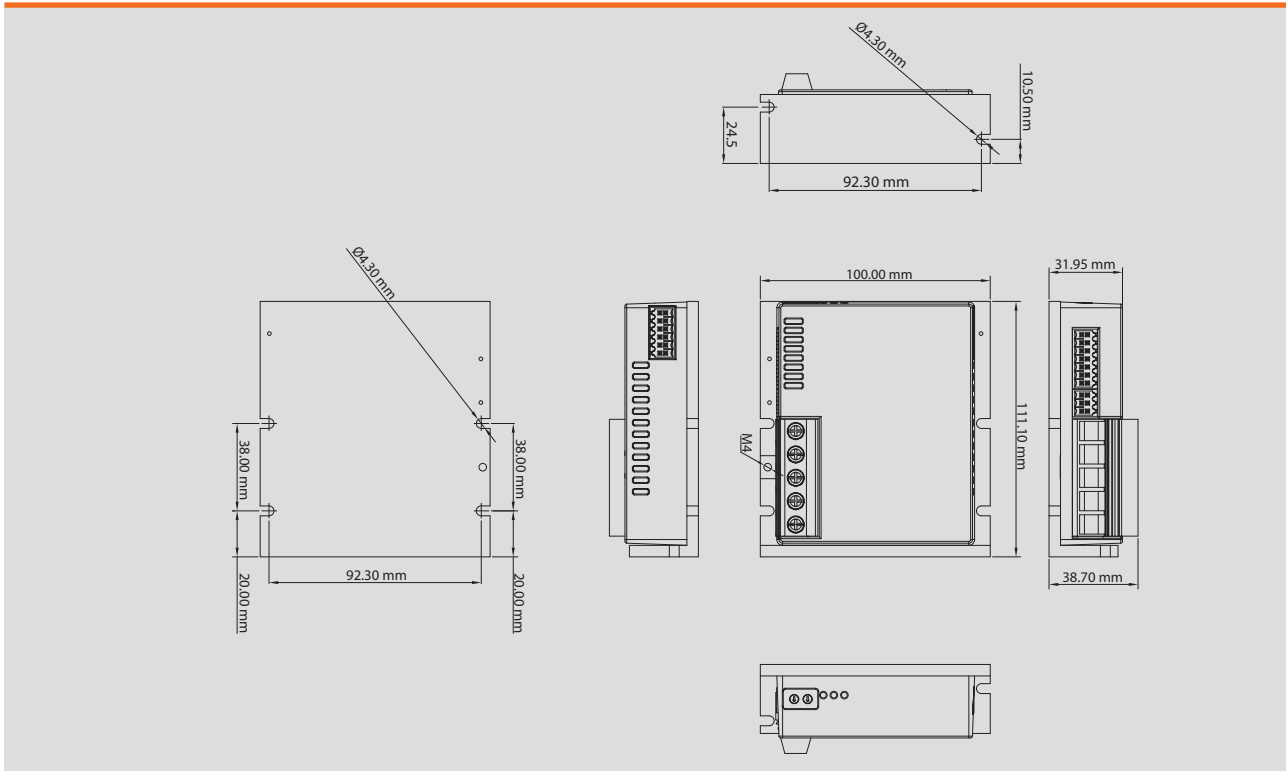

Dimensional Drawing HCL 225 E

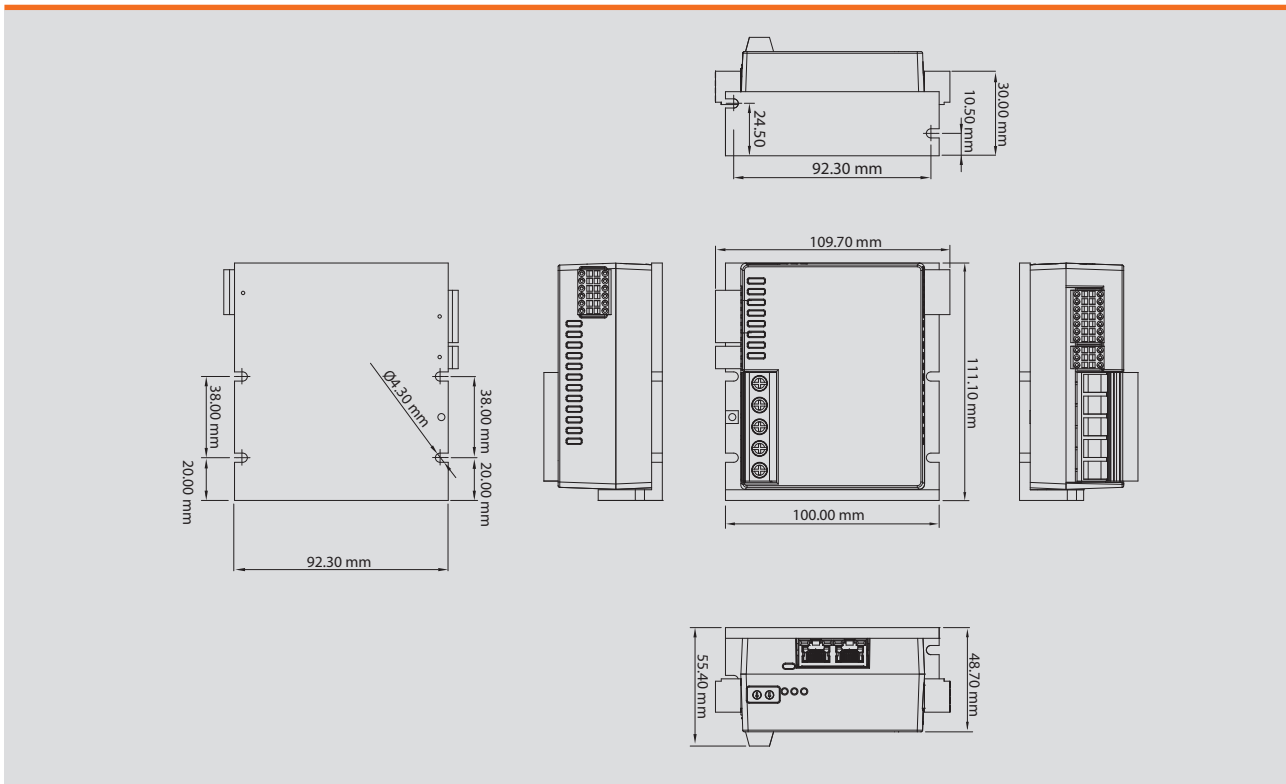

Technical data subject to change! Last changes: 10/2024

Heidrive GmbH

Starenstraße 23
D-93309 Kelheim

Phone +49 9441/707-0
Fax +49 9441/707-259

info@heidrive.de
www.heidrive.com

