



HMD Next Generation - Servo Drive Systems

## ■ Introduction

The new highly dynamic HMD Next Generation series presents itself with overall lengths reduced by over 30 % compared to the predecessor motors and strongly optimised moments of inertia. The considerable reduction in length and the variety of flange sizes offer the optimum, highly dynamic solution for particularly small installation space. Numerous voltage variants and the finest power gradations leave nothing to be desired.

The HeiMotion Dynamic Next Generation motors are available in six different flange sizes:

- 60 mm - HMD06
- 80 mm - HMD08
- 100 mm - HMD10
- 130 mm - HMD13
- 150 mm - HMD15
- 190 mm - HMD19

Overview of features:

- 5 pole pairs
- Concentrated winding technology with high efficiency
- Voltage slope  $dU / dt$  14 kV /  $\mu s$  due to encapsulated stator and special connection technology
- Temperature sensor PT1000; optional KTY / PTC600
- Shortened end caps as standard for various encoders and plug-in systems

## ■ Contents

### General Information Page

---

Overview Motors	4
Mating Servo Drive Matrix	6
Operating Modes	8
Standards	9
Ambient Conditions and Technical Characteristics	10
Abbreviations and Definitions	11
Life Span	12
Order Code	13

HMD06

HMD08

HMD10

HMD13

### HeiMotion Dynamic Motors Page

---

HMD06	14
HMD08	26
HMD10	42
HMD13	58
HMD15	64
HMD19	70

HMD15

HMD19

### Motor Options Page

---

Configuration Options	76
Standard Resolver	80
Absolute Encoders AM 34	81
Options EnDAT® 2.2	82
Options HIPERFACE®	84
Options HIPERFACE DSL®	86
Options SSI / BiSS / Incremental encoders	88
Holding Brake	90
Connector Y-Tec	92
Connector M23	94
Connector M40 + M23	96
Terminal Box	98
Connectors for one Cable Solution	100

Encoder

Brake

Connector

### Servo Drives Page

---

HCB Servo Drive	104
HCL Low Voltage Servo Drive	110

Drives

# Overview

## HeiMotion Dynamic Next Generation Motors

Type	Model	$U_{bus}$	$I_o$	$I_n$	$M_o$	$M_n$	$M_{max}$	$n_n$	J	$P_n (S1)$
		[V <sub>DC</sub> ]	[A]	[A]	[Nm]	[Nm]	[Nm]	[rpm]	[kg/cm <sup>2</sup> ]	[W]
HMD06	HMD06-011	24	17.9	18.1	1.0	1.0	2.5	3,000	2.68E-01	315
		<b>48</b>	<b>9.6</b>	<b>10.0</b>	<b>1.0</b>	<b>1.0</b>	<b>2.5</b>	<b>3,000</b>	<b>2.68E-01</b>	<b>315</b>
		48	17.9	18.2	1.0	1.0	2.5	6,000	2.68E-01	630
		<b>320</b>	<b>1.29</b>	<b>1.34</b>	<b>1.0</b>	<b>1.0</b>	<b>2.5</b>	<b>3,000</b>	<b>2.68E-01</b>	<b>315</b>
		320	2.5	2.7	1.0	1.0	2.5	6,000	2.68E-01	630
		560	1.29	1.34	1.0	1.0	2.5	6,000	2.68E-01	630
	HMD06-019	560	1.3	1.4	1.0	1.0	2.5	6,000	2.68E-01	630
		<b>48</b>	<b>16.9</b>	<b>15.2</b>	<b>1.9</b>	<b>1.7</b>	<b>4.8</b>	<b>3,000</b>	<b>4.89E-01</b>	<b>530</b>
		<b>320</b>	<b>2.5</b>	<b>2.1</b>	<b>1.9</b>	<b>1.7</b>	<b>4.8</b>	<b>3,000</b>	<b>4.89E-01</b>	<b>530</b>
		320	4.6	3.6	1.9	1.45	4.8	6,000	4.89E-01	915
		560	1.3	1.2	1.9	1.7	4.8	3,000	4.89E-01	530
		560	2.5	2.0	1.9	1.45	4.8	6,000	4.89E-01	915
	HMD06-026	<b>48</b>	<b>20.4</b>	<b>20.0</b>	<b>2.6</b>	<b>2.5</b>	<b>6.5</b>	<b>3,000</b>	<b>7.11E-01</b>	<b>775</b>
		48	30.0 <sup>1)</sup>	30.0	2.0 <sup>1)</sup>	2.0	6.5	6,000	7.11E-01	1,250
		<b>320</b>	<b>3.2</b>	<b>3.2</b>	<b>2.6</b>	<b>2.5</b>	<b>6.5</b>	<b>3,000</b>	<b>7.11E-01</b>	<b>775</b>
		320	5.8	4.7	2.6	2.0	6.5	6,000	7.11E-01	1,250
		560	1.8	1.7	2.6	2.5	6.5	3,000	7.11E-01	775
		560	3.2	2.57	2.6	2.0	6.5	6,000	7.11E-01	1,250
HMD08	HMD08-024	24	45.3	45.4	2.4	2.3	6.0	3,000	8.00E-01	720
		<b>48</b>	<b>23.6</b>	<b>23.7</b>	<b>2.4</b>	<b>2.3</b>	<b>6.0</b>	<b>3,000</b>	<b>8.00E-01</b>	<b>720</b>
		48	45.3	42.5	2.4	2.1	6.0	5,500	8.00E-01	1,210
		<b>320</b>	<b>3.2</b>	<b>2.8</b>	<b>2.4</b>	<b>2.3</b>	<b>6.0</b>	<b>3,000</b>	<b>8.00E-01</b>	<b>720</b>
		320	5.4	4.9	2.4	2.1	6.0	5,500	8.00E-01	1,210
		<b>560</b>	<b>1.9</b>	<b>1.8</b>	<b>2.4</b>	<b>2.3</b>	<b>6.0</b>	<b>3,000</b>	<b>8.00E-01</b>	<b>720</b>
	HMD08-032	560	3.2	2.9	2.4	2.1	6.0	5,500	8.00E-01	1,210
		24	52.2	50.3	3.2	3.0	8.0	3,000	1.13E+00	940
		<b>48</b>	<b>27.6</b>	<b>26.6</b>	<b>3.2</b>	<b>3.0</b>	<b>8.0</b>	<b>3,000</b>	<b>1.13E+00</b>	<b>940</b>
		48	52.2	44.9	3.2	2.6	8.0	5,500	1.13E+00	1,500
		<b>320</b>	<b>4.3</b>	<b>4.2</b>	<b>3.2</b>	<b>3.0</b>	<b>8.0</b>	<b>3,000</b>	<b>1.13E+00</b>	<b>940</b>
		320	7.2	6.0	3.2	2.6	8.0	5,500	1.13E+00	1,500
	HMD08-042	<b>560</b>	<b>2.4</b>	<b>2.3</b>	<b>3.2</b>	<b>3.0</b>	<b>8.0</b>	<b>3,000</b>	<b>1.13E+00</b>	<b>940</b>
		560	4.3	3.6	3.2	2.6	8.0	5,500	1.13E+00	1,500
		24	62.4	59.9	4.2	3.9	10.5	3,000	1.46E+00	1,225
		<b>48</b>	<b>33.7</b>	<b>32.3</b>	<b>4.2</b>	<b>3.9</b>	<b>10.5</b>	<b>3,000</b>	<b>1.46E+00</b>	<b>1,225</b>
		48	62.4	54.0	4.2	3.4	10.5	5,500	1.46E+00	1,950
		<b>320</b>	<b>5.0</b>	<b>4.7</b>	<b>4.2</b>	<b>3.9</b>	<b>10.5</b>	<b>3,000</b>	<b>1.46E+00</b>	<b>1,225</b>
	HMD08-057	320	8.6	7.2	4.2	3.4	10.5	5,500	1.46E+00	1,950
		<b>560</b>	<b>2.7</b>	<b>2.6</b>	<b>4.2</b>	<b>3.9</b>	<b>10.5</b>	<b>3,000</b>	<b>1.46E+00</b>	<b>1,225</b>
		560	5.0	4.3	4.2	3.4	10.5	5,500	1.46E+00	1,950
		<b>48</b>	<b>47.7</b>	<b>54.8</b>	<b>5.7</b>	<b>5.3</b>	<b>14.3</b>	<b>3,000</b>	<b>2.12E+00</b>	<b>1,665</b>
		<b>320</b>	<b>6.5</b>	<b>6.1</b>	<b>5.7</b>	<b>5.3</b>	<b>14.3</b>	<b>3,000</b>	<b>2.12E+00</b>	<b>1,665</b>
		320	11.2	8.8	5.7	4.3	14.3	5,500	2.12E+00	2,480
HMD08-057	<b>560</b>	<b>3.4</b>	<b>3.3</b>	<b>5.7</b>	<b>5.3</b>	<b>14.3</b>	<b>3,000</b>	<b>2.12E+00</b>	<b>1,665</b>	
	560	6.5	5.1	5.7	4.3	14.3	5,500	2.12E+00	2,480	

<sup>1)</sup> Rated and/or standstill current of the motor greater than the rated current of the connection technology. When using this connection method, derating of the motor must be accepted.

Type	Model	$U_{bus}$ [V <sub>DC</sub> ]	$I_o$ [A]	$I_n$ [A]	$M_o$ [Nm]	$M_n$ [Nm]	$M_{max}$ [Nm]	$n_n$ [rpm]	J [kg-cm <sup>2</sup> ]	$P_n$ (S1) [W]
HMD10	HMD10-039	<b>48</b>	<b>34.6</b>	<b>32.9</b>	<b>3.9</b>	<b>3.6</b>	<b>9.8</b>	<b>3,000</b>	<b>1.94E+00</b>	<b>1,130</b>
		48	56.0	48.5	3.9	3.2	9.8	5,000	1.94E+00	1,675
		<b>320</b>	<b>5.0</b>	<b>4.7</b>	<b>3.9</b>	<b>3.6</b>	<b>9.8</b>	<b>3,000</b>	<b>1.94E+00</b>	<b>1,130</b>
		320	8.2	7.0	3.9	3.2	9.8	5,000	1.94E+00	1,675
		<b>560</b>	<b>2.8</b>	<b>2.7</b>	<b>3.9</b>	<b>3.6</b>	<b>9.8</b>	<b>3,000</b>	<b>1.94E+00</b>	<b>1,130</b>
	560	5.0	4.3	3.9	3.2	9.8	5,000	1.94E+00	1,675	
	HMD10-057	48	47.1	44.4	5.7	5.2	14.3	3,000	2.75E+00	1,635
		48	70.6	53.3	5.7	4.0	14.3	5,000	2.75E+00	2,095
		<b>320</b>	<b>6.5</b>	<b>6.1</b>	<b>5.7</b>	<b>5.2</b>	<b>14.3</b>	<b>3,000</b>	<b>2.75E+00</b>	<b>1,635</b>
		320	10.2	7.6	5.7	4.0	14.3	5,000	2.75E+00	2,095
		<b>560</b>	<b>3.6</b>	<b>3.4</b>	<b>5.7</b>	<b>5.2</b>	<b>14.3</b>	<b>3,000</b>	<b>2.75E+00</b>	<b>1,635</b>
	560	6.5	4.8	5.7	4.0	14.3	5,000	2.75E+00	2,095	
	HMD10-076	<b>48</b>	<b>57.7</b>	<b>50.3</b>	<b>7.6</b>	<b>6.5</b>	<b>19.0</b>	<b>3,000</b>	<b>3.57E+00</b>	<b>2,000</b>
		<b>320</b>	<b>9.1</b>	<b>8.0</b>	<b>7.6</b>	<b>6.5</b>	<b>19.0</b>	<b>3,000</b>	<b>3.57E+00</b>	<b>2,000</b>
		320	13.5	9.4	7.6	4.8	19.0	5,000	3.57E+00	2,500
		<b>560</b>	<b>4.9</b>	<b>4.3</b>	<b>7.6</b>	<b>6.5</b>	<b>19.0</b>	<b>3,000</b>	<b>3.57E+00</b>	<b>2,000</b>
		560	9.1	6.3	7.6	4.8	19.0	5,000	3.57E+00	2,500
	HMD10-105	<b>48</b>	<b>82.3</b>	<b>70.6</b>	<b>10.5</b>	<b>8.6</b>	<b>26.3</b>	<b>3,000</b>	<b>5.21E+00</b>	<b>2,700</b>
		<b>320</b>	<b>11.0</b>	<b>9.0</b>	<b>10.5</b>	<b>8.6</b>	<b>26.3</b>	<b>3,000</b>	<b>5.21E+00</b>	<b>2,700</b>
		320	18.0	10.6	10.5	5.5	26.3	5,000	5.21E+00	2,900
<b>560</b>		<b>6.4</b>	<b>5.5</b>	<b>10.5</b>	<b>8.6</b>	<b>26.3</b>	<b>3,000</b>	<b>5.21E+00</b>	<b>2,700</b>	
560		6.5	9.0	10.5	5.5	26.3	5,000	5.21E+00	2,900	
HMD13	HMD13-133	560	5.5	4.8	13.3	11.5	33.3	2,000	8.21E+00	2,400
		<b>560</b>	<b>9.3</b>	<b>6.3</b>	<b>13.3</b>	<b>9.0</b>	<b>33.3</b>	<b>3,600</b>	<b>8.21E+00</b>	<b>3,400</b>
	HMD13-190	560	7.5	6.3	19.0	16.0	47.5	2,000	1.20E+01	3,350
		<b>560</b>	<b>13.7</b>	<b>8.2</b>	<b>19.0</b>	<b>11.2</b>	<b>47.5</b>	<b>3,600</b>	<b>1.20E+01</b>	<b>4,200</b>
HMD13-245	560	9.7	8.2	24.5	20.5	61.3	2,000	1.58E+01	4,300	
	<b>560</b>	<b>17.1</b>	<b>9.6</b>	<b>24.5</b>	<b>13.3</b>	<b>61.3</b>	<b>3,600</b>	<b>1.58E+01</b>	<b>5,000</b>	
HMD15	HMD15-036	560	15.1	11.7	36.0	28.0	72.0	2,000	3.87E+01	5,850
		<b>560</b>	<b>22.6</b>	<b>13.2</b>	<b>36.0</b>	<b>21.0</b>	<b>72.0</b>	<b>3,000</b>	<b>3.87E+01</b>	<b>6,600</b>
	HMD15-043	560	18.0	13.8	42.5	32.5	85.0	2,000	4.82E+01	6,800
		<b>560</b>	<b>26.0</b>	<b>15.3</b>	<b>42.5</b>	<b>25.0</b>	<b>85.0</b>	<b>3,000</b>	<b>4.82E+01</b>	<b>7,850</b>
	HMD15-049	560	20.4	15.5	49.0	37.0	98.0	2,000	5.76E+01	7,750
		<b>560</b>	<b>30.0</b>	<b>17.8</b>	<b>49.0</b>	<b>29.0</b>	<b>98.0</b>	<b>3,000</b>	<b>5.76E+01</b>	<b>9,110</b>
HMD19	HMD19-051	560	24.5	16.6	51.0	35.5	102.0	2,000	7.42E+01	7,435
		560	35.9	17.6	51.0	25.5	102.0	3,000	7.42E+01	8,000
	HMD19-078	<b>560</b>	<b>38.0</b>	<b>24.4</b>	<b>78.0</b>	<b>51.5</b>	<b>156.0</b>	<b>2,000</b>	<b>1.10E+02</b>	<b>10,780</b>
		560	56.6	24.1	78.0	34.0	156.0	3,000	1.10E+02	10,680
	HMD19-105	<b>560</b>	<b>52.5</b>	<b>32.5</b>	<b>105.0</b>	<b>66.5</b>	<b>210.0</b>	<b>2,000</b>	<b>1.45E+02</b>	<b>13,920</b>

#### Standard version

If different from the standard version, longer delivery times are to be expected.

## HeiMotion Dynamic Motors Mating Servo Drive Matrix

Type	Model	n [rpm]	U <sub>bus</sub> [V <sub>DC</sub> ]	I <sub>o</sub> [A]	HCB		HCL	HCL
					1 x 230 V <sub>AC</sub>	3 x 400 V <sub>AC</sub>	24 - 48 V <sub>DC</sub>	24 - 48 V <sub>DC</sub>
HMD06	HMD06-011	3000	24	17.9			HCL 60 C	HCL 120C/E
		3000	48	9.6			HCL 60 C	HCL 120C/E
		6000	48	17.9			HCL 60 C	HCL 120C/E
		3000	320	1.29	HCB 2/6-1	HCB 4/12-3		
		6000	320	2.5	HCB 4/12-1	HCB 4/12-3		
		3000	560	1.29		HCB 4/12-3		
	HMD06-019	6000	560	1.3		HCB 4/12-3		
		3000	48	16.9			HCL 60 C	HCL 120C/E
		3000	320	2.5	HCB 4/12-1	HCB 4/12-3		
		6000	320	4.6	HCB 8/24-1	HCB 8/24-3		
		3000	560	1.3		HCB 4/12-3		
	HMD06-026	6000	560	2.5		HCB 4/12-3		
		3000	48	20.4			HCL 225 CS/C/E	
		6000	48	30.0 <sup>1)</sup>			HCL 225 CS/C/E	
		3000	320	3.2	HCB 4/12-1	HCB 4/12-3		
6000		320	5.8	HCB 8/24-1	HCB 8/24-3			
HMD08	HMD08-024	3000	560	1.8		HCB 4/12-3		
		6000	560	3.2		HCB 4/12-3		
		3000	24	45.3			HCL 225 CS/C/E	
		3000	48	23.6			HCL 225 CS/C/E	
		5500	48	45.3			HCL 225 CS/C/E	
		3000	320	3.2	HCB 4/12-1	HCB 4/12-3		
		5500	320	5.4	HCB 8/24-1	HCB 8/24-3		
	HMD08-032	3000	560	1.9		HCB 4/12-3		
		5500	560	3.2		HCB 4/12-3		
		3000	24	52.2				
		3000	48	27.6			HCL 225 CS/C/E	
		5500	48	52.2				
		3000	320	4.3	HCB 4/12-1	HCB 8/24-3		
		5500	320	7.2	HCB 8/24-1	HCB 8/24-3		
	HMD08-042	3000	560	2.4		HCB 4/12-3		
		5500	560	4.3		HCB 8/24-3		
		3000	24	62.4				
		3000	48	33.7			HCL 225 CS/C/E	
		5500	48	62.4				
		3000	320	5.0	HCB 8/24-1	HCB 8/24-3		
		5500	320	8.6		HCB 12/30-3		
	HMD08-057	3000	560	2.7		HCB 4/12-3		
		5500	560	5.0		HCB 8/24-3		
		3000	48	47.7				
3000		320	3.4	HCB 8/24-1	HCB 8/24-3			
5500		320	6.5		HCB 12/30-3			
	3000	560	3.6		HCB 4/12-3			
	5500	560	6.6		HCB 8/24-3			

<sup>1)</sup> Rated and/or standstill current of the motor greater than the rated current of the connection technology. When using this connection method, derating of the motor must be accepted.

Type	Model	n [rpm]	U <sub>bus</sub> [V <sub>DC</sub> ]	I <sub>o</sub> [A]	HCB		HCL	HCL
					1 x 230 V <sub>AC</sub>	3 x 400 V <sub>AC</sub>	24 - 48 V <sub>DC</sub>	24 - 48 V <sub>DC</sub>
HMD10	HMD10-039	3000	48	34.6			HCL 225 C/CS/E	
		5000	48	56				
		3000	320	5	HCB 8/24-1	HCB 8/24-3		
		5000	320	8.2		HCB 12/30-3		
		3000	560	2.8		HCB 4/12-3		
		5000	560	5		HCB 8/24-3		
	HMD10-057	3000	48	47.1				
			5000	48	70.6			
		3000	320	6.5	HCB 8/24-1	HCB 8/24-3		
			5000	320	10.2		HCB 12/30-3	
		3000	560	3.6		HCB 4/12-3		
			5000	560	6.5		HCB 8/24-3	
	HMD10-076	3000	48	57.7				
			3000	320	9.1		HCB 12/30-3	
		5000	320	13.5		HCB 20/50-3		
			3000	560	4.9		HCB 8/24-3	
		5000	560	9.1		HCB 12/30-3		
	HMD10-105	3000	48	82.3				
			3000	320	11		HCB 12/30-3	
		5000	320	18		HCB 20/50-3		
3000			560	6.4		HCB 8/24-3		
5000		560	11		HCB 12/30-3			
HMD13	HMD13-133	2000	560	5.5		HCB 8/24-3		
		3600	560	9.3		HCB 12/30-3		
	HMD13-190	2000	560	7.5		HCB 8/24-3		
		3600	560	13.7		HCB 20/50-3		
	HMD13-245	2000	560	9.7		HCB 12/30-3		
		3600	560	17.1		HCB 20/50-3		
HMD15	HMD15-036	2000	560	15.1		HCB 20/50-3		
		3000	560	22.6		HCB 40/100-3		
	HMD15-043	2000	560	18		HCB 20/50-3		
		3000	560	26		HCB 40/100-3		
	HMD15-049	2000	560	20.4		HCB 40/100-3		
		3000	560	30		HCB 40/100-3		
HMD19	HMD19-051	2000	560	24.5		HCB 40/100-3		
		3000	560	35.9		HCB 40/100-3		
	HMD19-078	2000	560	38		HCB 40/100-3		
		3000	560	56.6				
	HMD19-105	2000	560	52.5				



HCB  
p. 104



HCL  
p. 110

# Operating Modes

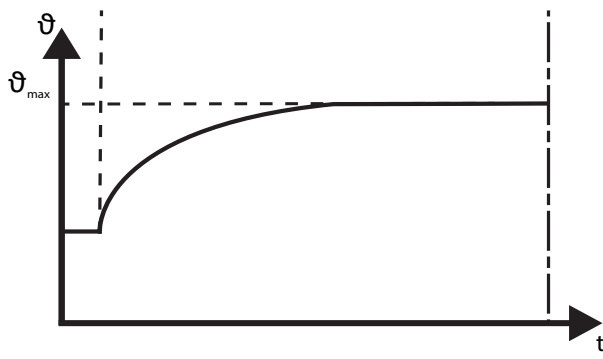
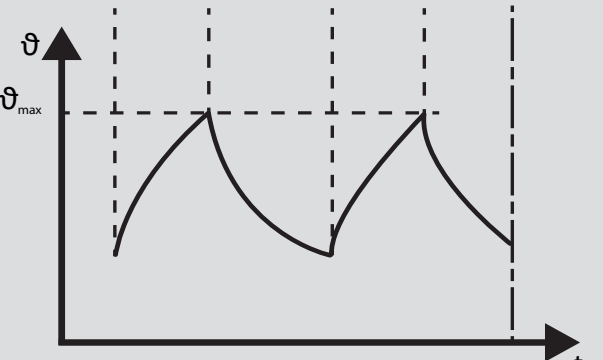
	Definition	Graph
S1	Continuous operation with constant load	
S3	Periodic intermittent operation without influence of the starting process on motor heating	

## ■ Applied Harmonized Standards

Standard	Explanation
EN ISO 12100:2010	Safety of machinery General design principles Risk assessment and risk reduction
EN 60034-1:2010 + Cor.:2010	Rotating electrical machines Part 1: Dimensioning and operating behavior
EN 60204-1:2018	Safety of machinery Electrical equipment of machines Part 1: General requirements
EN 60529:1991 + A1:2000 + A2:2013	Degrees of protection by enclosure (IP code)
EN IEC 60664-1:2020	Insulation coordination for equipment in low-voltage power supply systems Part 1: Principles, requirements and tests

## ■ General Information

### Ambient Conditions and Technical Characteristics

Motor type	Permanent magnet three-phase synchronous servo motor	
Ambient operating temperature	- 10 °C to + 40 °C	
Ambient storage temperature	- 25 °C to + 70 °C	
Humidity	< 90 % relative humidity (without condensation)	
Insulation class	F (155 °C) $\Delta T = 115 K$	
Pollution level	2	
Protection class	IP65 as standard, shaft outlet IP21 (ball bearing with sealing disc on request) -Optional with shaft seal IP65 (no dry running)	
Max. mechanical rpm limit	10,000 rpm (higher upon request)	
Cooling	Natural convective	
Overvoltage category	II max. 4000 meters above sea level; III max. 3,000 meters above sea level	
Bearing life	20,000 h under rated operation conditions ( $M_r$ )	
Temperature sensor	PT1000; optional KTY / PTC600	
Voltage slew rate dU/dt	14 kV / $\mu s$	
Maximum altitude	4,000 meters above sealevel; derate 1 % per 100 meters above 1,000 meters	
Concentricity, coaxiality and axial run-out	N (normal) per DIN 42955	
Vibration	Stage N in accordance to ISO 2373	
Cogging torque factor $c_t$	HMD06	< 2.0 % based on the stall torque ( $M_o$ )
	HMD08	< 1.5 % based on the stall torque ( $M_o$ )
	HMD10	< 1.2 % based on the stall torque ( $M_o$ )
	HMD13 - 19	< 1.0 % based on the stall torque ( $M_o$ )
Coating	Black top coat, RAL 9005	
Magnet material	Neodymium-Iron-Boron (NdFeB)	
Shaft end	Cylindrical shaft end with / without keyway	
Balancing quality	Q 2.5	
Encoder systems	Resolver, HIPERFACE®, HIPERFACE DSL®, Incremental encoder, SSI/BISS, EnDAT® 2.2	
Approvals	CE,  - certification (see E341694)	

## Abbreviations and Definitions

Abbr.	Unit	Tolerance	Explanation
$f_n$	[Hz]	-	Rated frequency
$I_0$	[A <sub>rms</sub> ]	± 10 %	Stall current per phase (motor current at stall torque $M_0$ )
$I_n$	[A <sub>rms</sub> ]	± 10 %	Rated current (rated current per phase)
$I_{max}$	[A <sub>rms</sub> ]	-	Peak current (maximum permissible current per phase)
J	[kg-cm <sup>2</sup> ]	-	Moment of inertia rotor (motor without brake)
$k_e$	[V <sub>rms</sub> / krpm]	± 6 %	Voltage constant (induced voltage between two phases at 1,000 rpm) rms (root mean square value)
$k_{tn}$	[Nm / A <sub>rms</sub> ]	± 6 %	Torque constant (rms) at nominal point at 20 °C
$L_{p-p}$	[mH]	-	Winding inductance (2 phases) at rated current $I_n$
m	[kg]	-	Weight (motor without brake)
$M_0$	[Nm]	± 10 %	Stall torque (stall torque at S1)
$M_n$	[Nm]	± 10 %	Rated torque (continuous torque at S1)
$M_{max}$	[Nm]	-	Peak torque (maximum permissible torque for short periods)
$n_n$	[rpm]	-	Rated speed
$n_{max}$	[rpm]	-	Maximum speed
$P_n$	[W]	-	Rated power (mechanical power at the shaft)
$R_{p-p}$	[Ω]	± 5 % ± 10 %	Winding resistance (2 phases, at winding temperature of 20 °C), ± 5 % for 320/560 V <sub>DC</sub> , ± 10 % for 24/48 V <sub>DC</sub> motors
$C_t$	[%]	-	Local cogging torque $C_t = \frac{M_{cmax} - M_{cmin}}{M_0} \times 100 \%$
$M_{cmax}$	[Nm]	-	Local maximum of the cogging torque
$M_{cmin}$	[Nm]	-	Local minimum of the cogging torque
$T_{el}$	[ms]	-	Electrical time constant
$T_{th}$	[min]	-	Thermal time constant
$U_{mot}$	[V <sub>rms</sub> ]	-	Rated motor voltage (2 phases at rated working point), rms
$U_{bus}$	[V <sub>DC</sub> ]	-	DC bus voltage

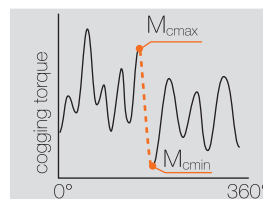

# Life Span

## Shaft Loading Forces

Life span of the motors is at least 20,000 hours if operated under rated conditions. The table below shows admissible radial forces for the bearing load. Point of force application is in the middle of the shaft (see drawing).

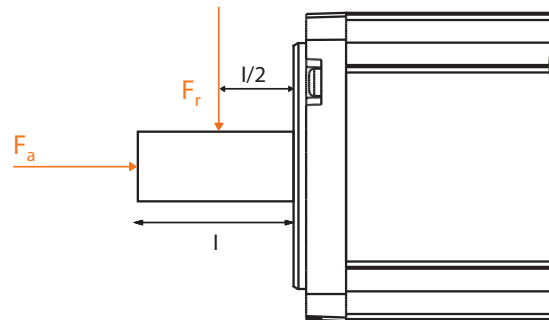

## Maximum Radial Force $F_r$ , [N]

	1,000 [rpm]	2,000 [rpm]	3,000 [rpm]	4,000 [rpm]	5,000 [rpm]	6,000 [rpm]	7,000 [rpm]	8,000 [rpm]	9,000 [rpm]	10,000 [rpm]
HMD06-011	355	280	245	220	205	195	185	175	170	160
HMD06-019	390	310	270	240	230	210	200	190	185	180
HMD06-026	400	320	280	260	240	220	210	200	195	190
HMD08-024	430	340	300	270	250	240	225	215	-	-
HMD08-032	460	370	320	290	270	250	240	230	-	-
HMD08-042	480	380	330	300	280	265	250	240	-	-
HMD08-057	510	410	350	320	300	280	270	260	-	-
HMD10-039	800	640	560	510	470	440	420	-	-	-
HMD10-057	850	670	590	535	500	470	445	-	-	-
HMD10-076	885	705	615	560	520	490	465	-	-	-
HMD10-105	940	740	650	615	570	540	510	-	-	-
HMD13-133	1,260	1,000	880	790	740	-	-	-	-	-
HMD13-190	1,340	1,070	930	840	780	-	-	-	-	-
HMD13-245	1,400	1,110	970	880	820	-	-	-	-	-
HMD15-036	1,640	1,300	1,140	1,030	-	-	-	-	-	-
HMD15-043	1,690	1,340	1,170	1,070	-	-	-	-	-	-
HMD15-049	1,730	1,370	1,200	1,090	-	-	-	-	-	-
HMD19-051	2,390	1,900	1,660	1,510	-	-	-	-	-	-
HMD19-078	2,530	2,010	1,750	1,590	-	-	-	-	-	-
HMD19-105	2,620	2,080	1,810	1,650	-	-	-	-	-	-

Maximum axial force:  $F_a = 0.2 \times F_r$

At stall, a one-time axial force of 40 % of the radial force may be applied during motor mounting. Maximum allowed axial and radial forces must not occur together at the same time.

## Order Code

HMD08-024-320-30-BPH2MW23W		Options	Page
<b>Frame/flange size</b>		Without brake	0XXXXXXXXX
60 mm → 06		With brake	BXXXXXXXXX 90
80 mm → 08		Without feather key	X0XXXXXXXX
100 mm → 10		With feather key	XPXXXXXXXX
130 mm → 13		Resolver	XXR1PXXXX 80
150 mm → 15		Resolver safely mounted	XXRAPXXXX
190 mm → 19		HES 1 (1.0 V <sub>p-p</sub> )	XXM2SXXXX 88
<b>Stall torque</b>		HEM 1 (1.0 V <sub>p-p</sub> without battery)	XXM1MXXXX 88
1.1 Nm → 011		HEM 1 (1.0 V <sub>p-p</sub> with battery)	XXM2MXXXX 88
1.9 Nm → 019		HES 3	XXM3IXXXX 88
2.4 Nm → 024		AM34 (Singleturn)	XXS1SXXXX 81
2.6 Nm → 026		AM34 (Multiturn)	XXB1MXXXX 81
3.2 Nm → 032		ECI 1118	XXE1SXXXX 82
3.9 Nm → 039		EQI 1131	XXE1MXXXX 82
4.2 Nm → 042		ECI 1319	XXE3SXXXX 82
5.7 Nm → 057		EQI 1331	XXE3MXXXX 82
7.6 Nm → 076		SEK 37	XXH1SXXXX 84
10.5 Nm → 105		SEL 37	XXH1MXXXX 84
13.3 Nm → 133		SKS 36	XXH2SXXXX 84
19.0 Nm → 190		SKS 36S safely mounted	XXHBSXXXX 84
24.5 Nm → 245		SKM 36	XXH2MXXXX 84
36.0 Nm → 036		SKM 36S safely mounted	XXHBMXXXX 84
42.5 Nm → 043		SRS 50	XXH3SXXXX 84
49.0 Nm → 049		SRM 50	XXH3MXXXX 84
51.0 Nm → 051		EES 37	XXD1SXXXX 86
78.0 Nm → 078		EES 37-2 safely mounted	XXDASXXXX 86
105.0 Nm → 105		EEM 37	XXD1MXXXX 86
<b>DC bus voltage</b>		EEM 37-2 safely mounted	XXDAMXXXX 86
24 V → 024		EKS 36	XXD2SXXXX 86
48 V → 048		EKS 36-2 safely mounted	XXDBSXXXX 86
320 V → 320		EKM 36	XXD2MXXXX 86
560 V → 560		EKM 36-2 safely mounted	XXDBMXXXX 86
<b>Rated speed</b>		EDS 35	XXD3SXXXX 86
2,000 rpm → 20		EDM 35	XXD3MXXXX 86
3,000 rpm → 30		M23 angled	XXXXXW23X 94
3,600 rpm → 36		M40 angled	XXXXXW40X 96
5,000 rpm → 50		M23 angled one cable solution	XXXXX I 23 X 102
5,500 rpm → 55		M40 angled one cable solution	XXXXX I 40 X 103
6,000 rpm → 60		Y-Tec	XXXXXY17X 92
		I-Tec	XXXXXI17X 100
		Cable outlet 1.5m <sup>1)</sup>	XXXXXK15X
		Cable outlet 5m <sup>1)</sup>	XXXXXK50X
		Terminal box <sup>1)2)</sup>	XXXXXKB0X 98
		Terminal box <sup>1)2)</sup>	XXXXXKB2X 98
		Terminal box <sup>1)2)</sup>	XXXXXKA0X 98
		Terminal box <sup>1)2)</sup>	XXXXXKA2X 98
		Without radial shaft seal	XXXXXXXXX0
		With radial shaft seal	XXXXXXXXXW
		AS ball bearing <sup>1)</sup> with double rubber seals <sup>1)</sup>	XXXXXXXXXD

1) Upon request

2) Mounting direction and cable gland see page 98/99

Example: HMD08-024-320-30-BPH2MW23W		Options:
Frame/flange size 80 mm		With brake
Stall torque 2.4 Nm		Without feather key
DC bus voltage 320 V		Encoder SKM 36
Rated speed 3,000 rpm		Angled connector M23
		With radial shaft seal

# ■ HMD06-011

## 24 / 48 V



## Specifications

HMD06-011

Rated speed [rpm]	$n_n$	3,000	3,000	6,000
Number of pole pairs		5	5	5
Wiring of the motor winding		Y	Y	Y
DC bus voltage [V <sub>DC</sub> ]	$U_{bus}$	24	48	48
Rated voltage motor [V <sub>rms</sub> ]	$U_{mot}$	14.6	26.2	26.2
Rated power [W] <sup>1)</sup>	$P_n$	315	315	630
Rated torque [Nm]	$M_n$	1.0	1.0	1.0
Rated current per phase [A <sub>rms</sub> ]	$I_n$	18.1	10.0	18.2
<b>Stall torque [Nm]</b>	<b><math>M_0</math></b>	<b>1.0</b>	<b>1.0</b>	<b>1.0</b>
Stall current per phase [A <sub>rms</sub> ]	$I_0$	17.9	9.6	17.9
Peak torque [Nm]	$M_{max}$	2.5	2.5	2.5
Peak current [A <sub>rms</sub> ]	$I_{max}$	53.2	26.4	53.4
Maximum speed [rpm]	$n_{max}$	3,620	4,520	7,410
Voltage constant at 1.000 rpm [V <sub>rms</sub> ]	$k_e$	3.50	6.5	3.50
Torque constant [Nm / A <sub>rms</sub> ]	$k_t$	0.055	0.100	0.055
Winding resistance (2 phases) at 20 °C [Ω]	$R_{p-p}$	0.1	0.4	0.1
Winding inductance (2 phases) [mH]	$L_{p-p}$	0.1	0.4	0.1
Electrical time constant [ms]	$t_{el}$	1.1	1.1	1.1
Thermal time constant [min]	$t_{th}$	25	25	25
Moment of inertia rotor [kg-cm <sup>2</sup> ]	$J$	2.68E-01	2.68E-01	2.68E-01
Weight of motor [kg]	$m$	1.2	1.2	1.2

For standstill / rated current greater than 30 A, observe connection technology (Page 78) and encoder selection (Page 76)!  
Other voltage variants available on request.  
All nominal values with resolver.

## Performance

HMD06-011-024-30-\*

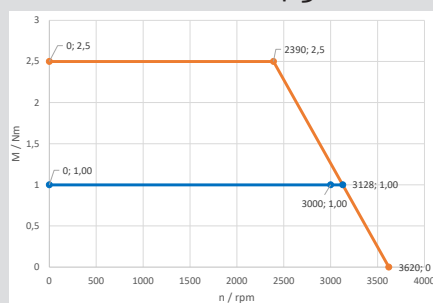

— M max  
— M (S1)

HMD06-011-048-30-\*

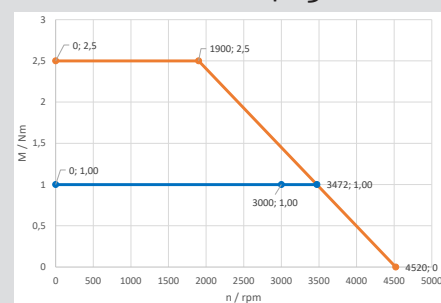

<sup>1)</sup> For UL approval, an S1 characteristic curve deviating by approx. 15 % applies. The specifications on the nameplates correspond to the UL values.

## Dimensions

HMD06

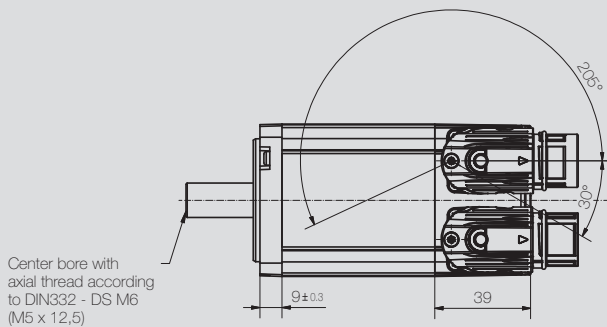
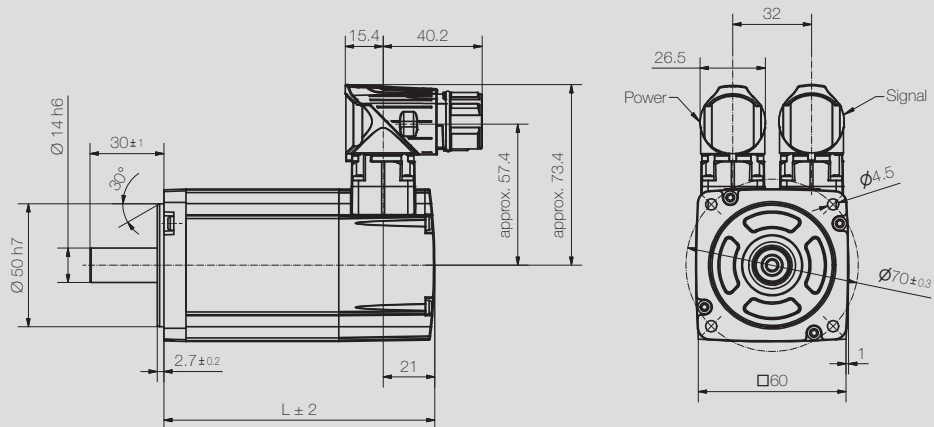

Feather key (option)

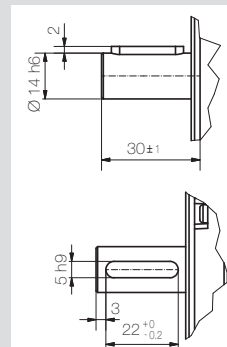

L [mm]

Motor	without brake	with brake
HMD06-011	110 mm	149 mm

### HMD06-011-048-60-\*

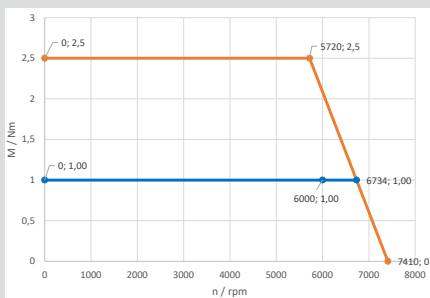

# ■ HMD06-011

320 / 560 V



## Specifications

		HMD06-011			
Rated speed [rpm]	$n_n$	3,000	6,000	3,000	6,000
Number of pole pairs		5	5	5	5
Wiring of the motor winding		Y	Y	Y	Y
DC bus voltage [V <sub>DC</sub> ]	$U_{bus}$	320	320	560	560
Rated voltage motor [V <sub>rms</sub> ]	$U_{mot}$	192.4	181.0	192.4	347.0
Rated power [W]	$P_n$	315	630	315	630
Rated torque [Nm]	$M_n$	1.0	1.0	1.0	1.0
Rated current per phase [A <sub>rms</sub> ]	$I_n$	1.34	2.7	1.34	1.4
<b>Stall torque [Nm]</b>	<b><math>M_0</math></b>	<b>1.0</b>	<b>1.0</b>	<b>1.0</b>	<b>1.0</b>
Stall current per phase [A <sub>rms</sub> ]	$I_0$	1.29	2.5	1.29	1.3
Peak torque [Nm]	$M_{max}$	2.5	2.5	2.5	2.5
Peak current [A <sub>rms</sub> ]	$I_{max}$	3.8	7.1	3.8	3.8
Maximum speed [rpm]	$n_{max}$	4,540	8,000	7,595	7,595
Voltage constant at 1.000 rpm [V <sub>rms</sub> ]	$k_e$	48.1	25.4	48.1	48.1
Torque constant [Nm / A <sub>rms</sub> ]	$k_t$	0.748	0.378	0.748	0.714
Winding resistance (2 phases) at 20 °C [Ω]	$R_{p-p}$	21.0	5.9	21.0	21.0
Winding inductance (2 phases) [mH]	$L_{p-p}$	25.5	7.0	25.5	25.2
Electrical time constant [ms]	$t_{el}$	1.2	1.2	1.2	1.2
Thermal time constant [min]	$t_{th}$	25	25	25	25
Moment of inertia rotor [kg-cm <sup>2</sup> ]	J	2.68E-01	2.68E-01	2.68E-01	2.68E-01
Weight of motor [kg]	m	1.2	1.2	1.2	1.2

For standstill / rated current greater than 30 A, observe connection technology (Page 78) and encoder selection (Page 76)!  
Other voltage variants available on request.  
All nominal values with resolver.

## Performance

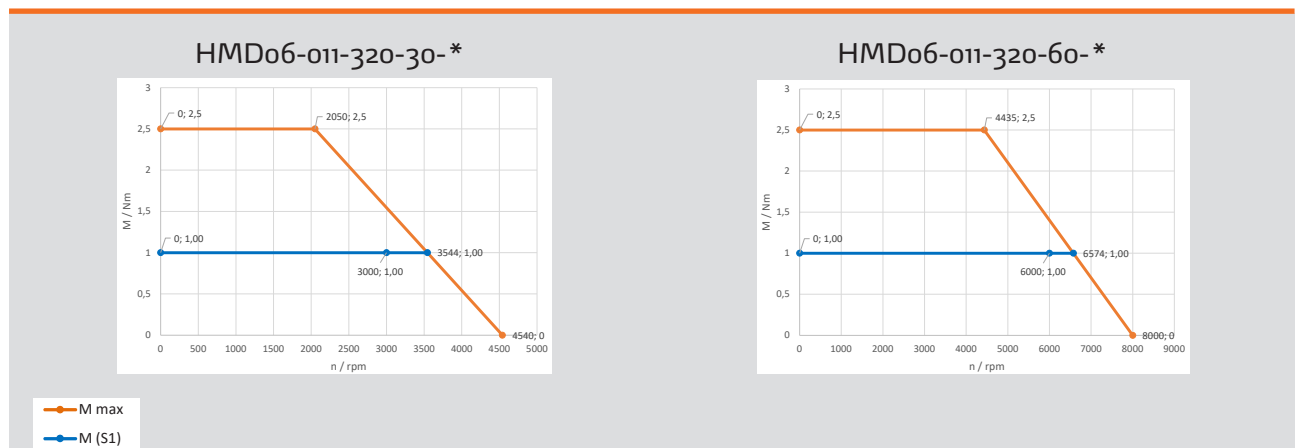

## Dimensions

HMD06

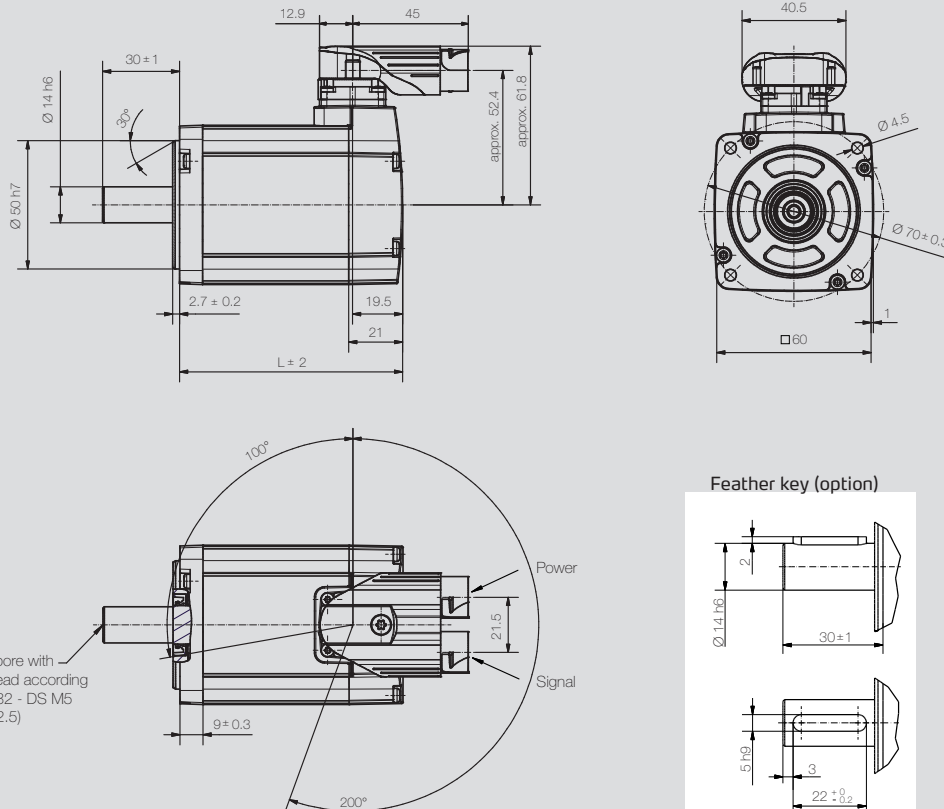

Motor	L [mm] with encoder category 1*		L [mm] with encoder category 2*	
	without brake	with brake	without brake	with brake
HMD06-011	92 mm	131 mm	110 mm	149 mm

\* Encoder category 1: Resolver, SEK/SEL37, HESx/HEMx, AM 34; only for variants with  $U_{bus} = 320/560 V_{DC}$   
Encoder category 2: Remaining encoders

HMD06-011-560-30-\*

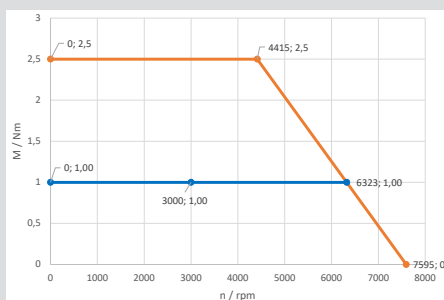

HMD06-011-560-60-\*

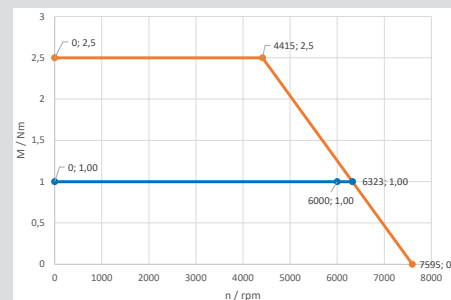

# ■ HMD06-019

## 48 V



## Specifications

HMD06-019

Rated speed [rpm]	$n_n$	3,000
Number of pole pairs		5
Wiring of the motor winding		Y
DC bus voltage [V <sub>DC</sub> ]	$U_{bus}$	48
Rated voltage motor [V <sub>rms</sub> ]	$U_{mot}$	25.6
Rated power [W] <sup>1)</sup>	$P_n$	530
Rated torque [Nm]	$M_n$	1.7
Rated current per phase [A <sub>rms</sub> ]	$I_n$	15.2
<b>Stall torque [Nm]</b>	<b><math>M_0</math></b>	<b>1.9</b>
Stall current per phase [A <sub>rms</sub> ]	$I_0$	16.9
Peak torque [Nm]	$M_{max}$	4.8
Peak current [A <sub>rms</sub> ]	$I_{max}$	48.5
Maximum speed [rpm]	$n_{max}$	4,000
Voltage constant at 1.000 rpm [V <sub>rms</sub> ]	$k_e$	7.1
Torque constant [Nm / A <sub>rms</sub> ]	$k_t$	0.112
Winding resistance (2 phases) at 20 °C [Ω]	$R_{p-p}$	0.2
Winding inductance (2 phases) [mH]	$L_{p-p}$	0.2
Electrical time constant [ms]	$t_{el}$	1.4
Thermal time constant [min]	$t_{th}$	25
Moment of inertia rotor [kg-cm <sup>2</sup> ]	J	4.89E-01
Weight of motor [kg]	m	1.6

For standstill / rated current greater than 30 A, observe connection technology (Page 78) and encoder selection (Page 76)!  
Other voltage variants available on request.  
All nominal values with resolver.

## Performance

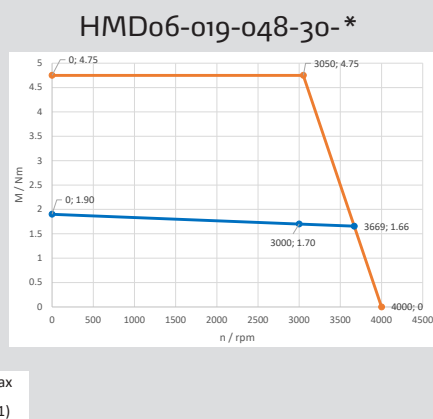

<sup>1)</sup> For UL approval, an S1 characteristic curve deviating by approx. 15 % applies. The specifications on the nameplates correspond to the UL values..

## Dimensions

HMD06

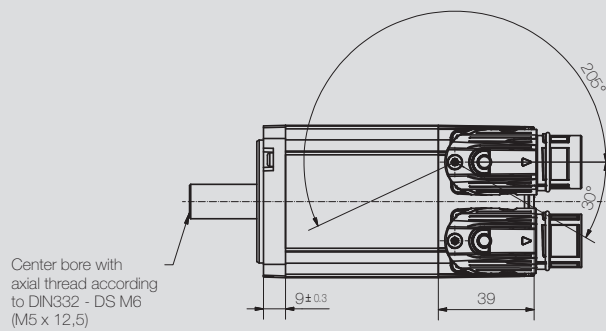
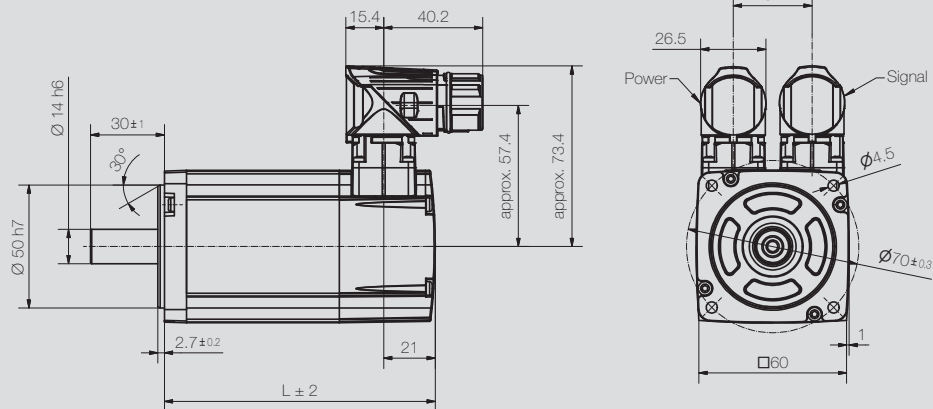

Feather key (option)

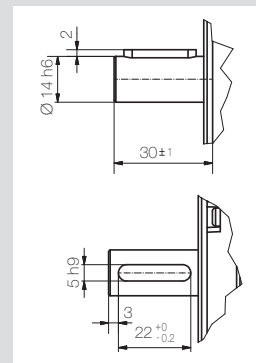

L [mm]

Motor	without brake	with brake
HMD06-019	135 mm	174 mm

# ■ HMD06-019

## 320 / 560 V



## Specifications

HMD06-019

Rated speed [rpm]	$n_n$	3,000	6,000	3,000	6,000
Number of pole pairs		5	5	5	5
Wiring of the motor winding		Y	Y	Y	Y
DC bus voltage [V <sub>DC</sub> ]	$U_{bus}$	320	320	560	560
Rated voltage motor [V <sub>rms</sub> ]	$U_{mot}$	168.0	167.0	312.0	331.0
Rated power [W]	$P_n$	530	915	530	915
Rated torque [Nm]	$M_n$	1.7	1.5	1.7	1.5
Rated current per phase [A <sub>rms</sub> ]	$I_n$	2.1	3.6	1.2	2.0
<b>Stall torque [Nm]</b>	<b><math>M_0</math></b>	<b>1.9</b>	<b>1.9</b>	<b>1.9</b>	<b>1.9</b>
Stall current per phase [A <sub>rms</sub> ]	$I_0$	2.5	4.6	1.30	2.5
Peak torque [Nm]	$M_{max}$	4.8	4.8	4.8	4.8
Peak current [A <sub>rms</sub> ]	$I_{max}$	6.7	12.3	3.5	6.7
Maximum speed [rpm]	$n_{max}$	4,370	8,140	4,025	7,335
Voltage constant at 1.000 rpm [V <sub>rms</sub> ]	$k_e$	48.4	26.5	91.1	48.4
Torque constant [Nm / A <sub>rms</sub> ]	$k_t$	0.802	0.398	1.440	0.722
Winding resistance (2 phases) at 20 °C [Ω]	$R_{p-p}$	7.1	2.2	24.8	7.1
Winding inductance (2 phases) [mH]	$L_{p-p}$	10.2	3.0	37.3	10.2
Electrical time constant [ms]	$t_{el}$	1.4	1.4	1.5	1.4
Thermal time constant [min]	$t_{th}$	25	25	25	25
Moment of inertia rotor [kg-cm <sup>2</sup> ]	J	4.89E-01	4.89E-01	4.89E-01	4.89E-01
Weight of motor [kg]	m	1.6	1.6	1.6	1.6

For standstill / rated current greater than 30 A, observe connection technology (Page 78) and encoder selection (Page 76)!  
Other voltage variants available on request.  
All nominal values with resolver.

## Performance

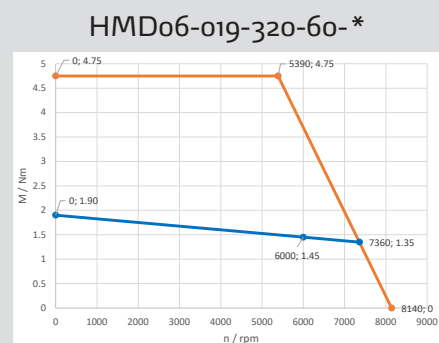
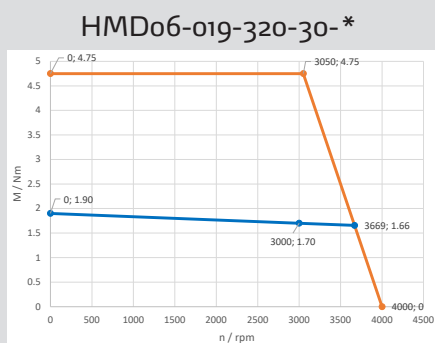

— M max  
— M (S1)

## Dimensions

HMD06

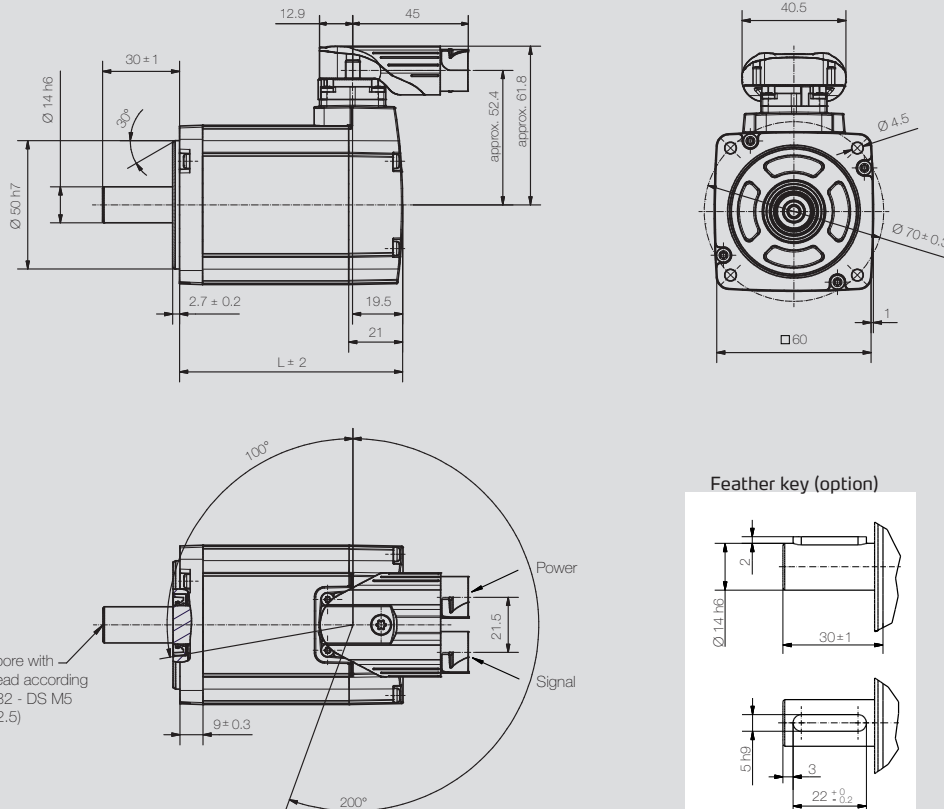

Motor	L [mm] with encoder category 1*		L [mm] with encoder category 2*	
	without brake	with brake	without brake	with brake
HMD06-019	117 mm	156 mm	135 mm	174 mm

\* Encoder category 1: Resolver, SEK/SEL37, HESx/HEMx, AM 34; only for variants with  $U_{bus} = 320/560 V_{DC}$   
Encoder category 2: Remaining encoders

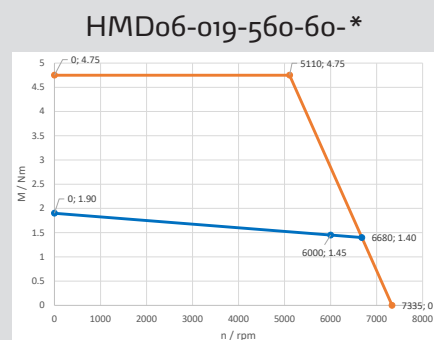
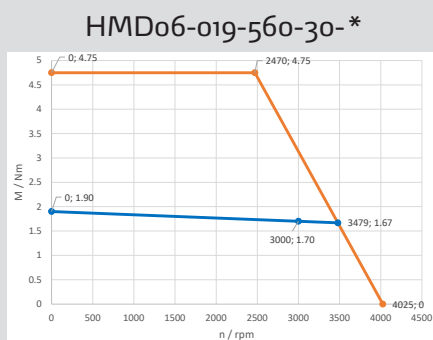

# HMD06-026

## 48 V



## Specifications

HMD06-026

Rated speed [rpm]	$n_n$	3,000	6,000
Number of pole pairs		5	5
Wiring of the motor winding		Y	Y
DC bus voltage [V <sub>DC</sub> ]	$U_{bus}$	48	48
Rated voltage motor [V <sub>rms</sub> ]	$U_{mot}$	27.4	27.1
Rated power [W] <sup>1)</sup>	$P_n$	785	1,250
Rated torque [Nm]	$M_n$	2.5	2.0
Rated current per phase [A <sub>rms</sub> ]	$I_n$	20.0	30.0
<b>Stall torque [Nm]</b>	<b><math>M_0</math></b>	<b>2.6</b>	<b>2.0<sup>2)</sup></b>
Stall current per phase [A <sub>rms</sub> ]	$I_0$	20.4	30.0 <sup>2)</sup>
Peak torque [Nm]	$M_{max}$	6.5	6.5
Peak current [A <sub>rms</sub> ]	$I_{max}$	53.6	108.0
Maximum speed [rpm]	$n_{max}$	3,785	6,990
Voltage constant at 1.000 rpm [V <sub>rms</sub> ]	$k_e$	8.0	4.2
Torque constant [Nm / A <sub>rms</sub> ]	$k_t$	0.125	0.066
Winding resistance (2 phases) at 20 °C [Ω]	$R_{p-p}$	0.12	0.03
Winding inductance (2 phases) [mH]	$L_{p-p}$	0.2	0.1
Electrical time constant [ms]	$t_{el}$	1.5	1.5
Thermal time constant [min]	$t_{th}$	25	25
Moment of inertia rotor [kg-cm <sup>2</sup> ]	$J$	7.11E-01	7.11E-01
Weight of motor [kg]	$m$	2.0	2.0

For standstill / rated current greater than 30 A, observe connection technology (Page 78) and encoder selection (Page 76)!  
Other voltage variants available on request.  
All nominal values with resolver.

## Performance

HMD06-026-048-30-\*

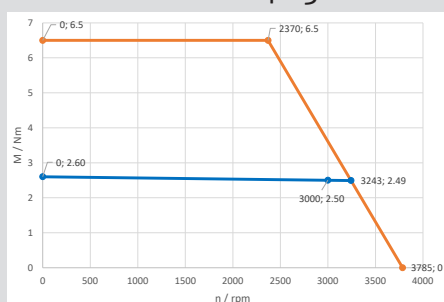

HMD06-026-048-60-\*

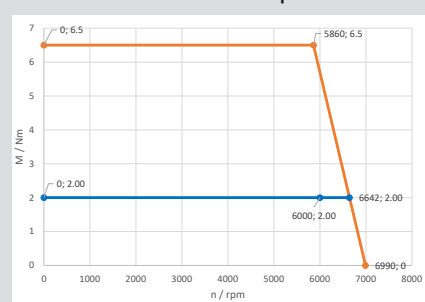

— M max  
— M (S1)

<sup>1)</sup> For UL approval, an S1 characteristic curve deviating by approx. 15 % applies. The specifications on the nameplates correspond to the UL values.

<sup>2)</sup> Rated and/or standstill current of the motor greater than the rated current of the connection technology. When using this connection method, derating of the motor must be accepted.

## Dimensions

HMD06

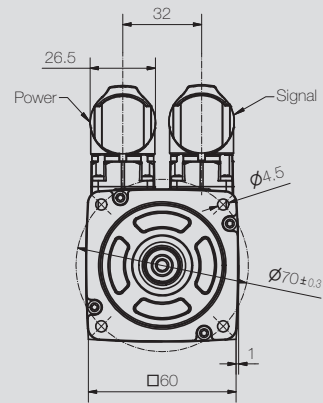
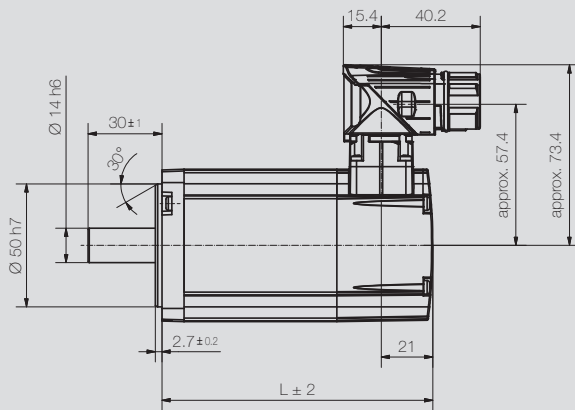

Feather key (option)

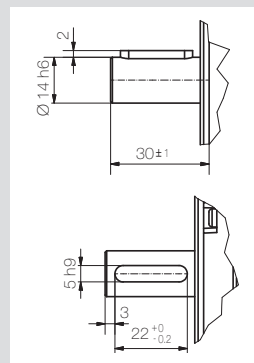

Center bore with axial thread according to DIN332 - DS M6 (M5 x 12,5)

L [mm]

Motor	without brake	with brake
HMD06-026	165 mm	204 mm

# HMD06-026

320 / 560 V



## Specifications

		HMD06-026			
Rated speed [rpm]	$n_n$	3,000	6,000	3,000	6,000
Number of pole pairs		5	5	5	5
Wiring of the motor winding		Y	Y	Y	Y
DC bus voltage [V <sub>DC</sub> ]	$U_{bus}$	320	320	560	560
Rated voltage motor [V <sub>rms</sub> ]	$U_{mot}$	168.0	172.0	317.0	309.0
Rated power [W]	$P_n$	785	1,250	785	1,250
Rated torque [Nm]	$M_n$	2.5	2.0	2.5	2.0
Rated current per phase [A <sub>rms</sub> ]	$I_n$	3.2	4.7	1.7	2.59
<b>Stall torque [Nm]</b>	<b><math>M_0</math></b>	<b>2.6</b>	<b>2.6</b>	<b>2.6</b>	<b>2.6</b>
Stall current per phase [A <sub>rms</sub> ]	$I_0$	3.2	5.8	1.8	3.2
Peak torque [Nm]	$M_{max}$	6.5	6.5	6.5	6.5
Peak current [A <sub>rms</sub> ]	$I_{max}$	8.5	16.3	4.4	8.5
Maximum speed [rpm]	$n_{max}$	4,130	7,210	3,645	6,595
Voltage constant at 1.000 rpm [V <sub>rms</sub> ]	$k_e$	50.2	27.6	97.1	50.2
Torque constant [Nm / A <sub>rms</sub> ]	$k_t$	0.793	0.427	1.510	0.772
Winding resistance (2 phases) at 20 °C [Ω]	$R_{p-p}$	4.8	1.5	17.9	4.80
Winding inductance (2 phases) [mH]	$L_{p-p}$	7.3	2.2	27.1	7.3
Electrical time constant [ms]	$t_{el}$	1.5	1.5	1.5	1.5
Thermal time constant [min]	$t_{th}$	25	25	25	25
Moment of inertia rotor [kg-cm <sup>2</sup> ]	$J$	7.11E-01	7.11E-01	7.11E-01	7.11E-01
Weight of motor [kg]	$m$	2.0	2.0	2.0	2.0

For standstill / rated current greater than 30 A, observe connection technology (Page 78) and encoder selection (Page 76)!  
Other voltage variants available on request.  
All nominal values with resolver.

## Performance

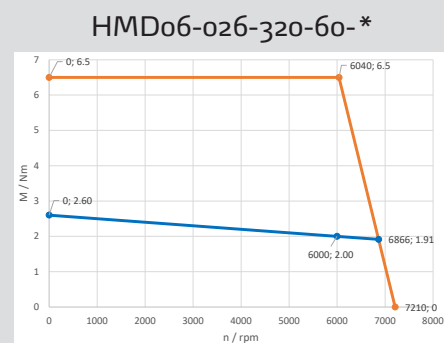
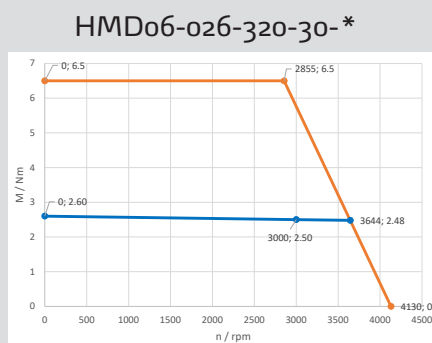

— M max  
— M (S1)

## Dimensions

HMD06

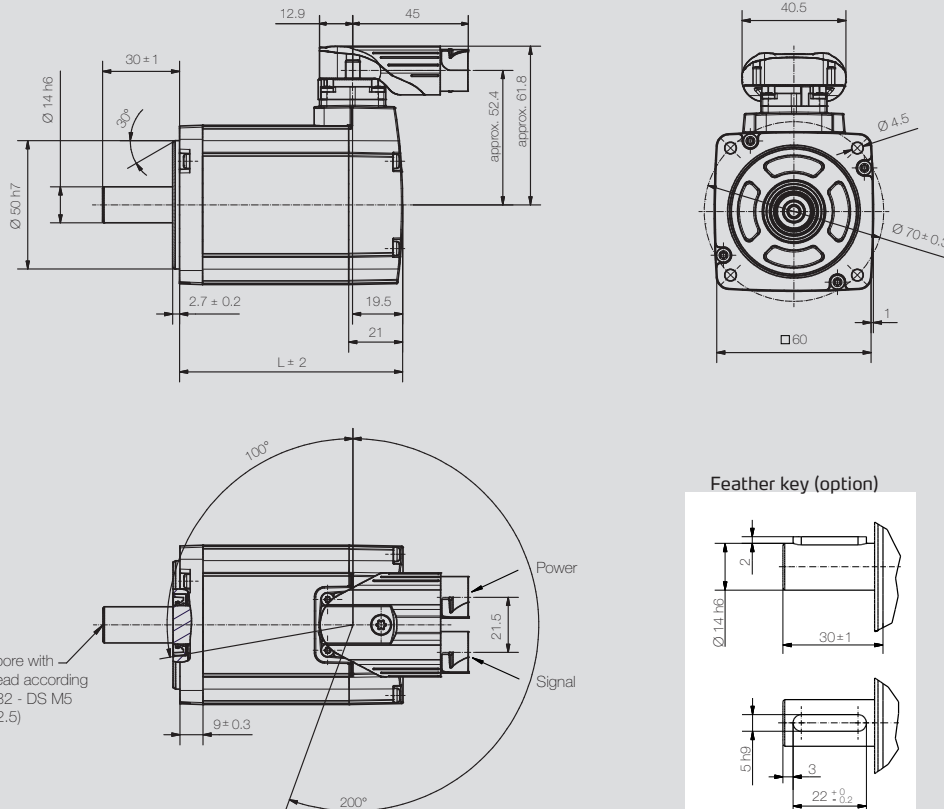

Motor	L [mm] with encoder category 1*		L [mm] with encoder category 2*	
	without brake	with brake	without brake	with brake
HMD06-026	147 mm	186 mm	165 mm	204 mm

\* Encoder category 1: Resolver, SEK/SEL37, HESx/HEMx, AM 34; only for variants with  $U_{bus} = 320/560 V_{DC}$   
Encoder category 2: Remaining encoders

HMD06-026-560-30-\*

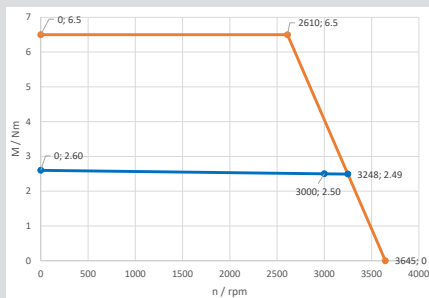

HMD06-026-560-60-\*

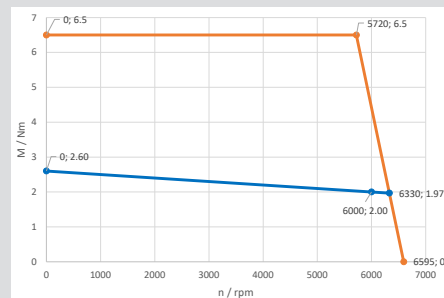

# HMD08-024

24 / 48 V



## Specifications

		HMD08-024		
Rated speed [rpm]	$n_n$	3,000	3,000	5,500
Number of pole pairs		5	5	5
Wiring of the motor winding		Y	Y	Y
DC bus voltage [V <sub>DC</sub> ]	$U_{bus}$	24	48	48
Rated voltage motor [V <sub>rms</sub> ]	$U_{mot}$	13.7	26.3	23.2
Rated power [W] <sup>1)</sup>	$P_n$	720	720	1,210
Rated torque [Nm]	$M_n$	2.3	2.3	2.1
Rated current per phase [A <sub>rms</sub> ]	$I_n$	45.4	23.7	42.5
<b>Stall torque [Nm]</b>	<b><math>M_0</math></b>	<b>2.4</b>	<b>2.4</b>	<b>2.4</b>
Stall current per phase [A <sub>rms</sub> ]	$I_0$	45.3	23.6	45.3
Peak torque [Nm]	$M_{max}$	6.0	6.0	6.0
Peak current [A <sub>rms</sub> ]	$I_{max}$	138.3	64.5	138.3
Maximum speed [rpm]	$n_{max}$	4,480	4,800	9,170
Voltage constant at 1.000 rpm [V <sub>rms</sub> ]	$k_e$	3.4	7.2	3.4
Torque constant [Nm / A <sub>rms</sub> ]	$k_t$	0.051	0.097	0.049
Winding resistance (2 phases) at 20 °C [Ω]	$R_{p-p}$	0.03	0.1	0.03
Winding inductance (2 phases) [mH]	$L_{p-p}$	0.1	0.3	0.1
Electrical time constant [ms]	$t_{el}$	2.3	2.3	2.4
Thermal time constant [min]	$t_{th}$	30	30	30
Moment of inertia rotor [kg-cm <sup>2</sup> ]	J	8.00E-01	8.00E-01	8.00E-01
Weight of motor [kg]	m	2.5	2.5	2.5

For standstill / rated current greater than 30 A, observe connection technology (Page 78) and encoder selection (Page 76)!  
Other voltage variants available on request.  
All nominal values with resolver.

## Performance

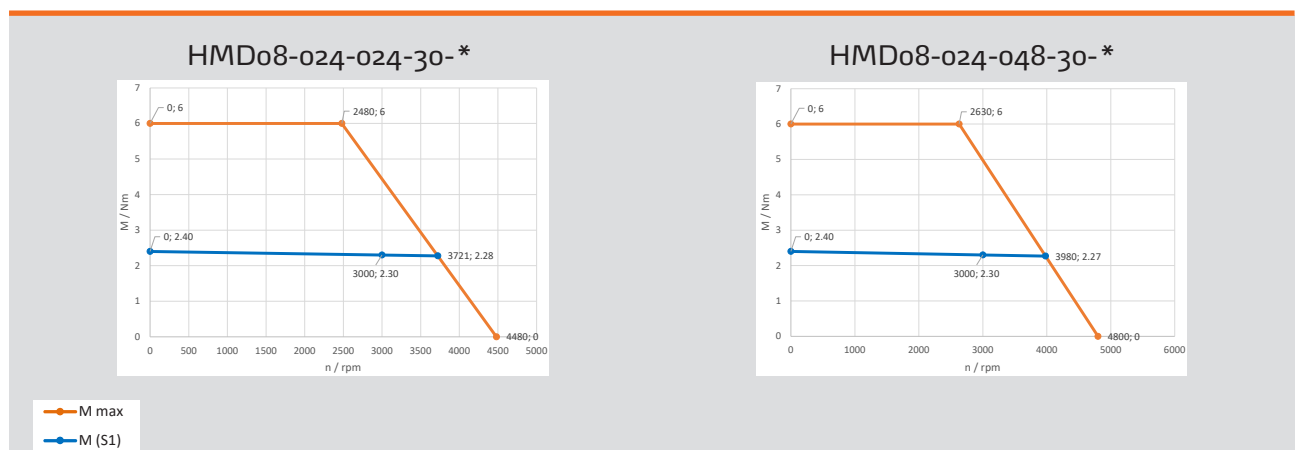

<sup>1)</sup> For UL approval, an S1 characteristic curve deviating by approx. 15 % applies. The specifications on the nameplates correspond to the UL values..

## Dimensions

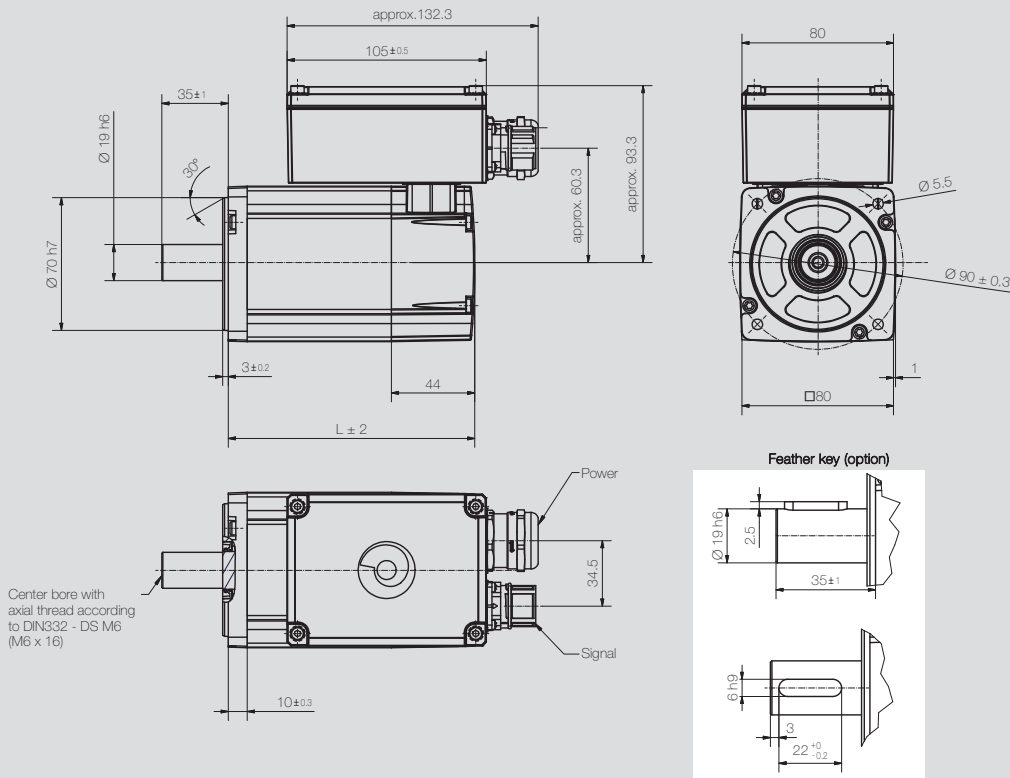

HMD08

Motor	L [mm]	
	without brake	with brake
HMD08-024	130 mm	178.5 mm

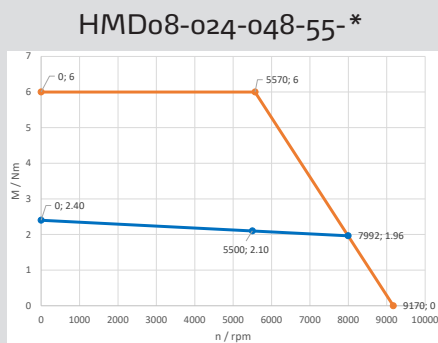

# ■ HMD08-024

## 320 / 560 V



## Specifications

HMD08-024

Rated speed [rpm]	$n_n$	3,000	5,500	3,000	5,500
Number of pole pairs		5	5	5	5
Wiring of the motor winding		Y	Y	Y	Y
DC bus voltage [V <sub>DC</sub> ]	$U_{bus}$	320	320	560	560
Rated voltage motor [V <sub>rms</sub> ]	$U_{mot}$	187.8	189.0	329.0	323.0
Rated power [W]	$P_n$	720	1,210	720	1,210
Rated torque [Nm]	$M_n$	2.3	2.1	2.3	2.1
Rated current per phase [A <sub>rms</sub> ]	$I_n$	2.8	4.9	1.8	2.9
<b>Stall torque [Nm]</b>	<b><math>M_0</math></b>	<b>2.4</b>	<b>2.4</b>	<b>2.4</b>	<b>2.4</b>
Stall current per phase [A <sub>rms</sub> ]	$I_0$	3.2	5.4	1.9	3.2
Peak torque [Nm]	$M_{max}$	6.0	6.0	6.0	6.0
Peak current [A <sub>rms</sub> ]	$I_{max}$	10.2	16.1	5.6	10.2
Maximum speed [rpm]	$n_{max}$	4,560	7,800	4,500	7,980
Voltage constant at 1.000 rpm [V <sub>rms</sub> ]	$k_e$	48.6	28.4	83.5	48.6
Torque constant [Nm / A <sub>rms</sub> ]	$k_t$	0.738	0.430	1.260	0.735
Winding resistance (2 phases) at 20 °C [Ω]	$R_{pp}$	6.0	2.2	19.8	6.0
Winding inductance (2 phases) [mH]	$L_{pp}$	14.4	5.0	45.7	14.4
Electrical time constant [ms]	$T_{el}$	2.4	2.3	2.3	2.4
Thermal time constant [min]	$T_{th}$	30	30	30	30
Moment of inertia rotor [kg-cm <sup>2</sup> ]	$J$	8.00E-01	8.00E-01	8.00E-01	8.00E-01
Weight of motor [kg]	$m$	2.5	2.5	2.5	2.5

For standstill / rated current greater than 30 A, observe connection technology (Page 78) and encoder selection (Page 76)!

Other voltage variants available on request.

All nominal values with resolver.

## Performance

HMD08-024-320-30-\*

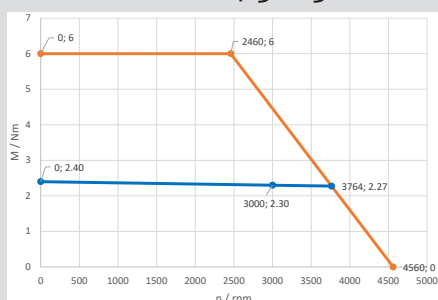

HMD08-024-320-55-\*

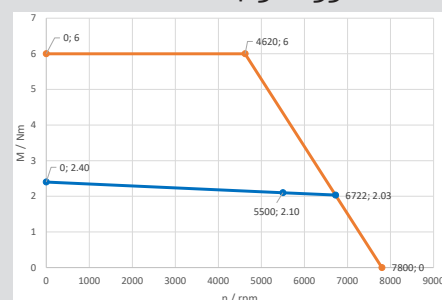

## Dimensions

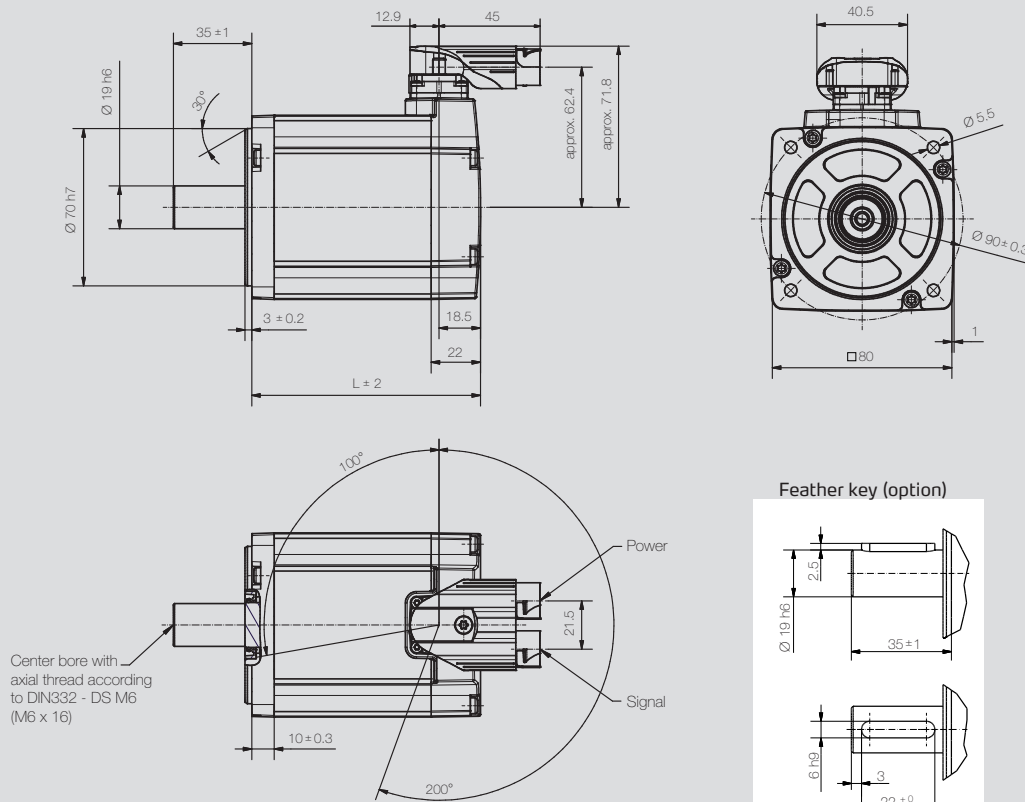

HMD08

Motor	L [mm] with encoder category 1*		L [mm] with encoder category 2*	
	without brake	with brake	without brake	with brake
HMD08-024	108 mm	156.5 mm	130 mm	178.5 mm

\* Encoder category 1: Resolver, SEK/SEL37, HESx/HENx, AM 34; only for variants with  $U_{\text{bus}} = 320/560\text{ V}_{\text{DC}}$   
Encoder category 2: Remaining encoders

HMD08-024-560-30-\*

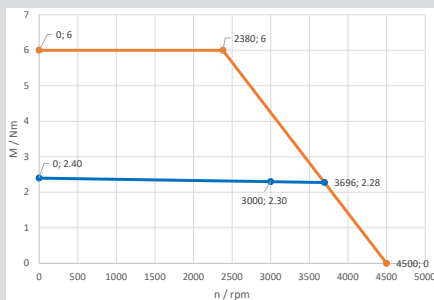

HMD08-024-560-55-\*

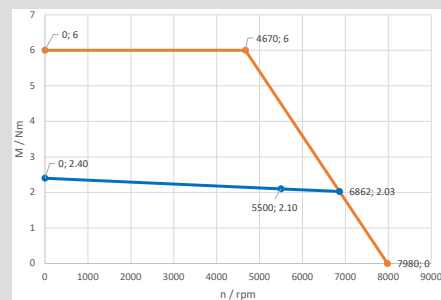

# ■ HMD08-032

## 24 / 48 V



## Specifications

HMD08-032

Rated speed [rpm]	$n_n$	3,000	3,000	5,500
Number of pole pairs		5	5	5
Wiring of the motor winding		Y	Y	Y
DC bus voltage [V <sub>DC</sub> ]	$U_{bus}$	24	48	48
Rated voltage motor [V <sub>rms</sub> ]	$U_{mot}$	14.3	27.2	24.6
Rated power [W] <sup>1)</sup>	$P_n$	940	940	1,500
Rated torque [Nm]	$M_n$	3.0	3.0	2.6
Rated current per phase [A <sub>rms</sub> ]	$I_n$	50.3	26.6	44.9
<b>Stall torque [Nm]</b>	<b><math>M_0</math></b>	<b>3.2</b>	<b>3.2</b>	<b>3.2</b>
Stall current per phase [A <sub>rms</sub> ]	$I_0$	52.2	27.6	52.2
Peak torque [Nm]	$M_{max}$	8.0	8.0	8.0
Peak current [A <sub>rms</sub> ]	$I_{max}$	163.0	86.3	163.0
Maximum speed [rpm]	$n_{max}$	3,720	4,000	7,610
Voltage constant at 1.000 rpm [V <sub>rms</sub> ]	$k_e$	3.9	7.4	3.9
Torque constant [Nm / A <sub>rms</sub> ]	$k_t$	0.060	0.113	0.058
Winding resistance (2 phases) at 20 °C [Ω]	$R_{p-p}$	0.02	0.1	0.02
Winding inductance (2 phases) [mH]	$L_{p-p}$	0.1	0.2	0.1
Electrical time constant [ms]	$t_{el}$	2.8	2.8	2.8
Thermal time constant [min]	$t_{th}$	30	30	30
Moment of inertia rotor [kg-cm <sup>2</sup> ]	J	1.13E+00	1.13E+00	1.13E+00
Weight of motor [kg]	m	2.9	2.9	2.9

For standstill / rated current greater than 30 A, observe connection technology (Page 78) and encoder selection (Page 76)!  
Other voltage variants available on request.  
All nominal values with resolver.

## Performance

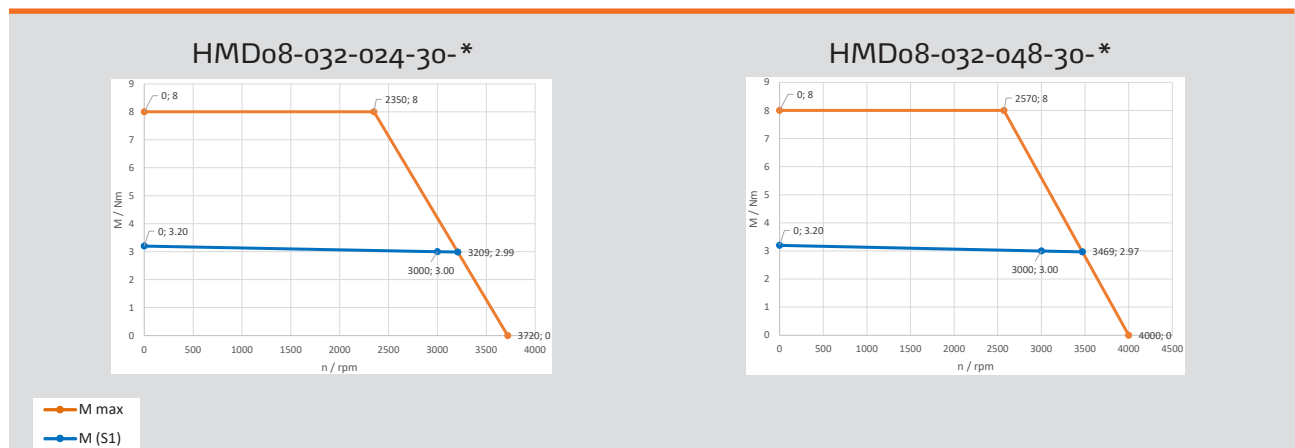

<sup>1)</sup> For UL approval, an S1 characteristic curve deviating by approx. 15 % applies. The specifications on the nameplates correspond to the UL values..

## Dimensions

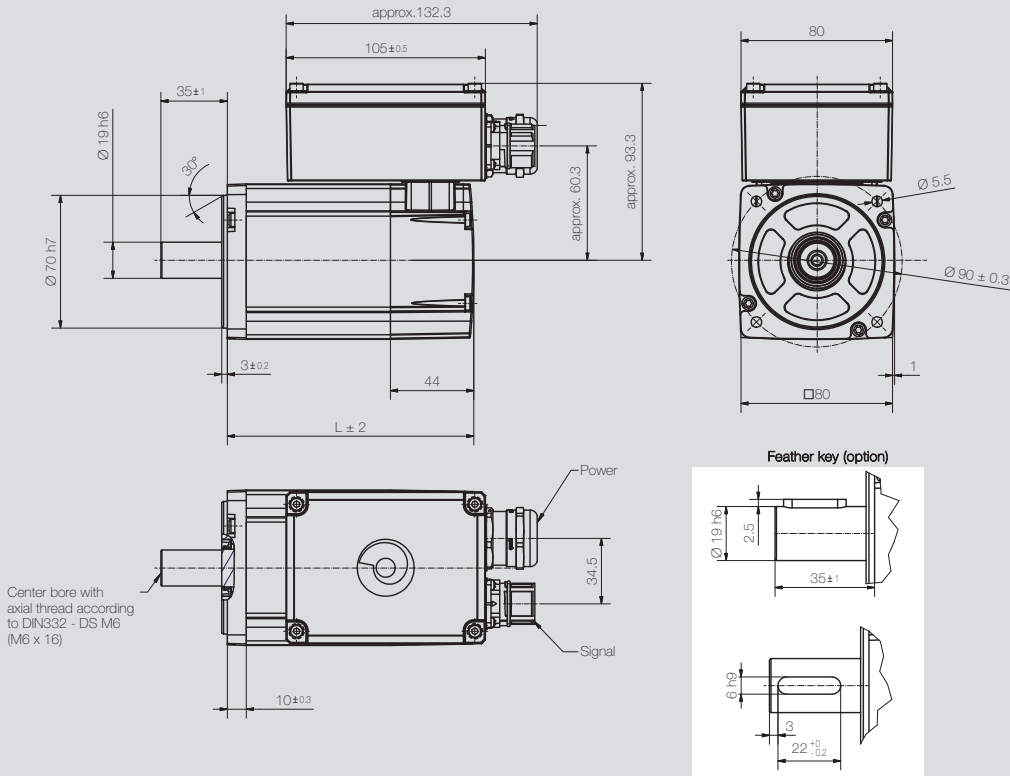

HMD08

L [mm]

Motor	without brake	with brake
HMD08-032	145 mm	193.5 mm

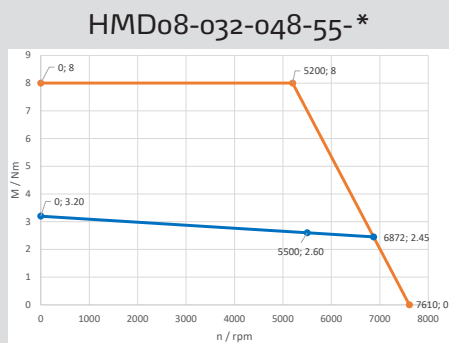

# ■ HMD08-032

## 320 / 560 V



## Specifications

HMD08-032

Rated speed [rpm]	$n_n$	3,000	5,500	3,000	5,500
Number of pole pairs		5	5	5	5
Wiring of the motor winding		Y	Y	Y	Y
DC bus voltage [V <sub>DC</sub> ]	$U_{bus}$	320	320	560	560
Rated voltage motor [V <sub>rms</sub> ]	$U_{mot}$	172.0	171.0	309.0	327.0
Rated power [W]	$P_n$	940	1,500	940	1,500
Rated torque [Nm]	$M_n$	3.0	2.6	3.0	2.6
Rated current per phase [A <sub>rms</sub> ]	$I_n$	4.2	6.0	2.3	3.6
<b>Stall torque [Nm]</b>	<b><math>M_0</math></b>	<b>3.2</b>	<b>3.2</b>	<b>3.2</b>	<b>3.2</b>
Stall current per phase [A <sub>rms</sub> ]	$I_0$	4.3	7.2	2.4	4.3
Peak torque [Nm]	$M_{max}$	8.0	8.0	8.0	8.0
Peak current [A <sub>rms</sub> ]	$I_{max}$	13.2	21.2	6.8	13.2
Maximum speed [rpm]	$n_{max}$	4,490	7,355	4,120	7,475
Voltage constant at 1.000 rpm [V <sub>rms</sub> ]	$k_e$	48.6	28.0	84.9	48.6
Torque constant [Nm / A <sub>rms</sub> ]	$k_t$	0.722	0.432	1.310	0.723
Winding resistance (2 phases) at 20 °C [Ω]	$R_{p-p}$	3.5	1.2	12.2	3.5
Winding inductance (2 phases) [mH]	$L_{p-p}$	10.0	3.3	34.4	10.0
Electrical time constant [ms]	$t_{el}$	2.9	2.9	2.8	2.9
Thermal time constant [min]	$t_{th}$	30	30	30	30
Moment of inertia rotor [kg-cm <sup>2</sup> ]	$J$	1.13E+00	1.13E+00	1.13E+00	1.13E+00
Weight of motor [kg]	$m$	2.9	2.9	2.9	2.9

For standstill / rated current greater than 30 A, observe connection technology (Page 78) and encoder selection (Page 76)!  
Other voltage variants available on request.  
All nominal values with resolver.

## Performance

HMD08-032-320-30-\*

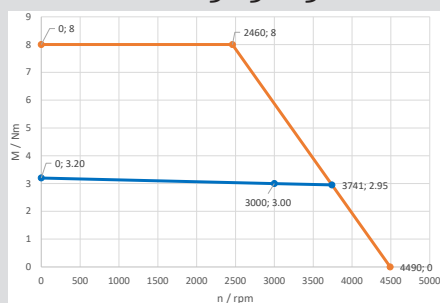

HMD08-032-320-55-\*

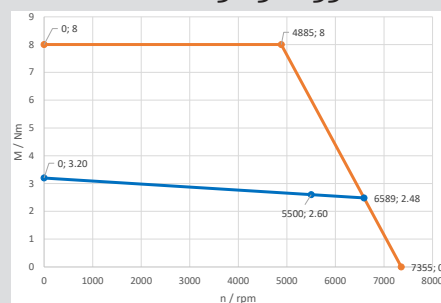

— M max  
— M (S1)

## Dimensions

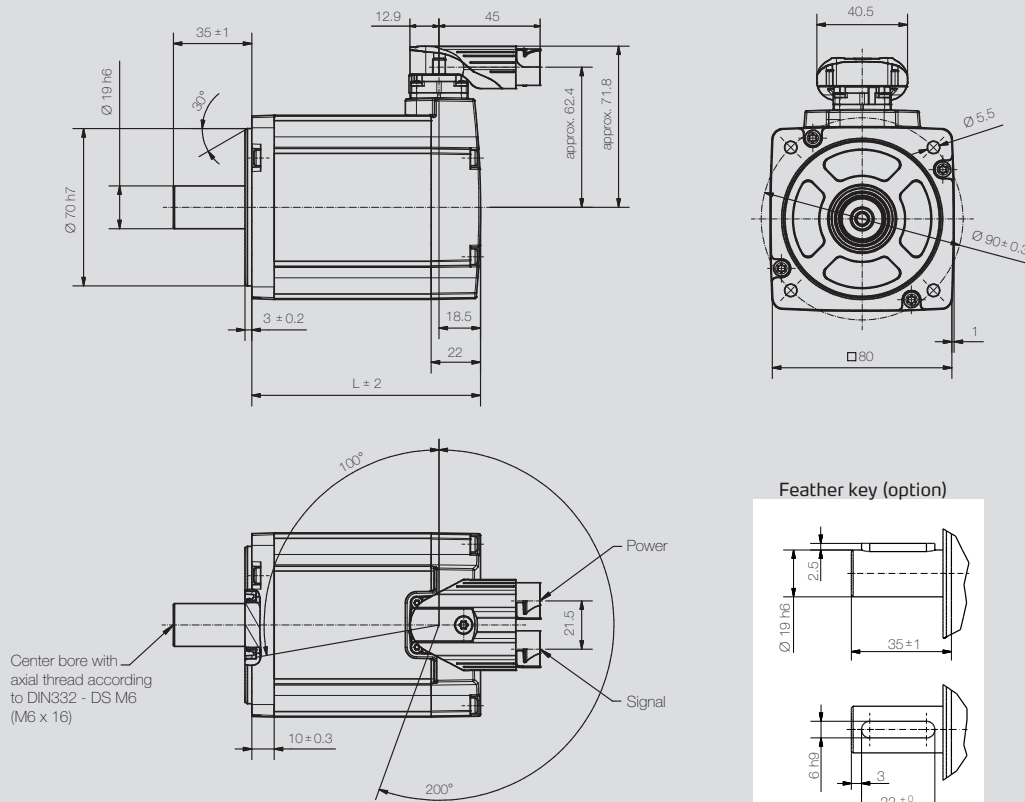

HMD08

Motor	L [mm] with encoder category 1*		L [mm] with encoder category 2*	
	without brake	with brake	without brake	with brake
HMD08-032	123 mm	171.5 mm	145 mm	193.5 mm

\* Encoder category 1: Resolver, SEK/SEL37, HESx/HENx, AM 34; only for variants with  $U_{bus} = 320/560 V_{DC}$   
Encoder category 2: Remaining encoders

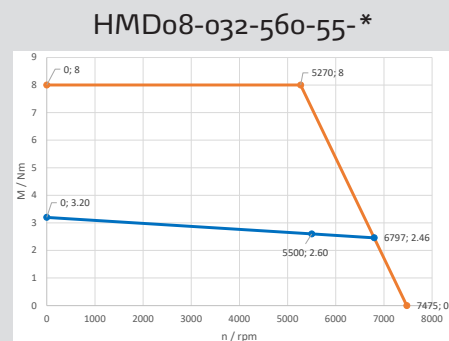
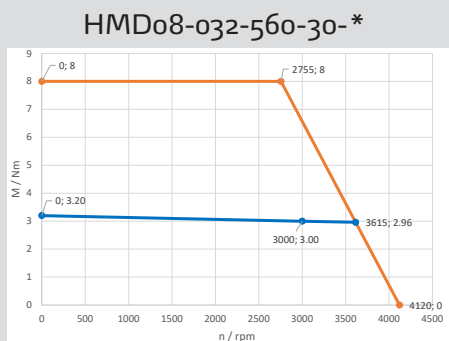

# ■ HMD08-042

24 / 48 V



## Specifications

		HMD08-042		
Rated speed [rpm]	$n_n$	3,000	3,000	5,500
Number of pole pairs		5	5	5
Wiring of the motor winding		Y	Y	Y
DC bus voltage [V <sub>DC</sub> ]	$U_{bus}$	24	48	48
Rated voltage motor [V <sub>rms</sub> ]	$U_{mot}$	14.8	27.4	25.6
Rated power [W] <sup>1)</sup>	$P_n$	1,225	1,225	1,950
Rated torque [Nm]	$M_n$	3.9	3.9	3.4
Rated current per phase [A <sub>rms</sub> ]	$I_n$	59.9	32.3	54.0
<b>Stall torque [Nm]</b>	<b><math>M_0</math></b>	<b>4.2</b>	<b>4.2</b>	<b>4.2</b>
Stall current per phase [A <sub>rms</sub> ]	$I_0$	62.4	33.7	62.4
Peak torque [Nm]	$M_{max}$	10.5	10.5	10.5
Peak current [A <sub>rms</sub> ]	$I_{max}$	191.0	102.8	190.0
Maximum speed [rpm]	$n_{max}$	3,550	3,850	7,250
Voltage constant at 1.000 rpm [V <sub>rms</sub> ]	$k_e$	4.2	7.9	4.2
Torque constant [Nm / A <sub>rms</sub> ]	$k_t$	0.065	0.121	0.063
Winding resistance (2 phases) at 20 °C [Ω]	$R_{p-p}$	0.02	0.1	0.02
Winding inductance (2 phases) [mH]	$L_{p-p}$	0.1	0.2	0.1
Electrical time constant [ms]	$t_{el}$	3.1	3.2	3.1
Thermal time constant [min]	$t_{th}$	30	30	30
Moment of inertia rotor [kg-cm <sup>2</sup> ]	$J$	1.46E+00	1.46E+00	1.46E+00
Weight of motor [kg]	$m$	3.3	3.3	3.3

For standstill / rated current greater than 30 A, observe connection technology (Page 78) and encoder selection (Page 76)!  
Other voltage variants available on request.  
All nominal values with resolver.

## Performance

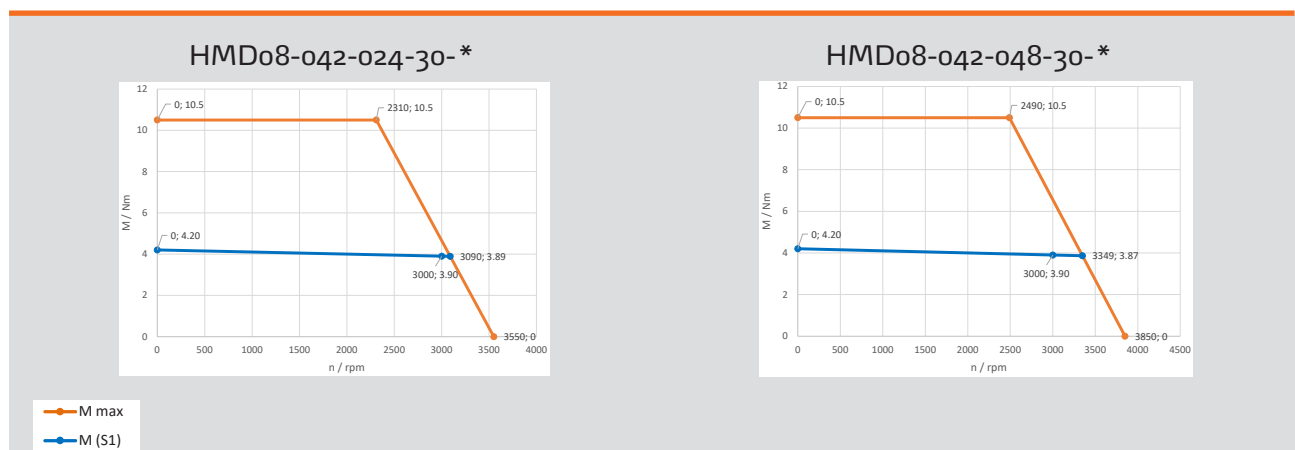

<sup>1)</sup> For UL approval, an S1 characteristic curve deviating by approx. 15 % applies. The specifications on the nameplates correspond to the UL values.

## Dimensions

HMD08

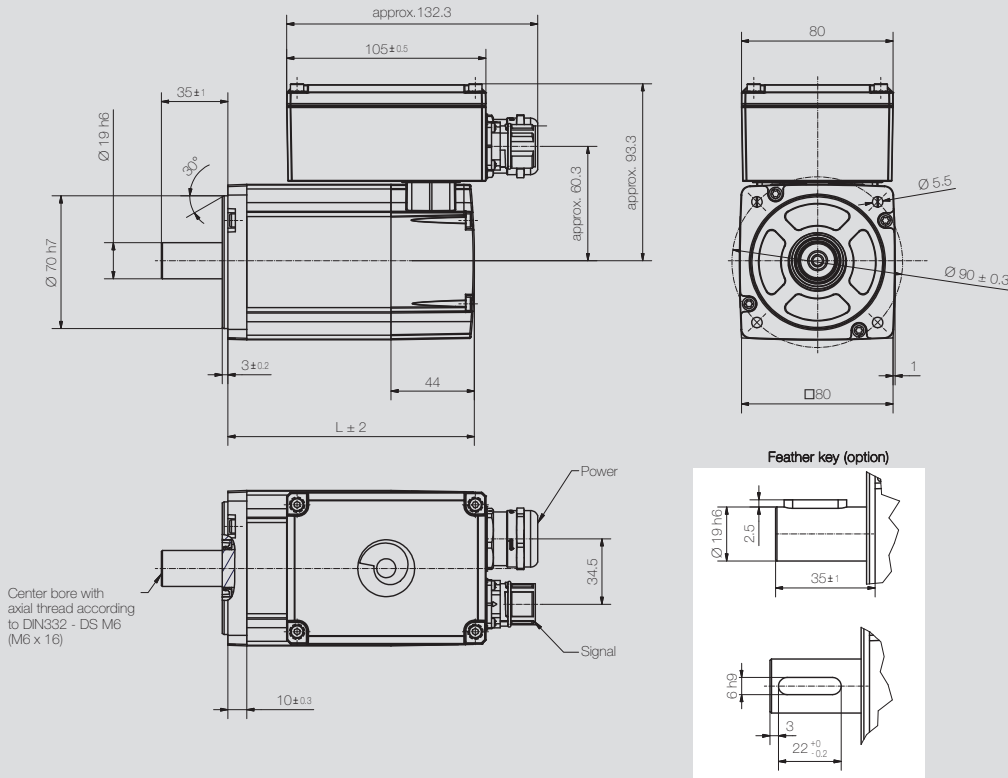

	L [mm]	
Motor	without brake	with brake
HMD08-042	160 mm	208.5 mm

HMD08-042-048-55-\*

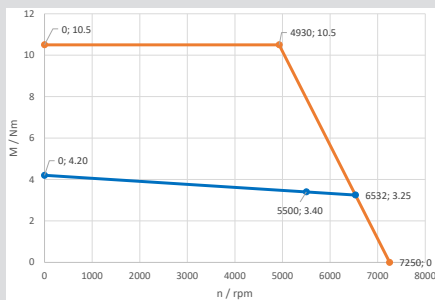

# ■ HMD08-042

320 / 560 V



## Specifications

HMD08-042

Rated speed [rpm]	$n_n$	3,000	5,500	3,000	5,500
Number of pole pairs		5	5	5	5
Wiring of the motor winding		Y	Y	Y	Y
DC bus voltage [V <sub>DC</sub> ]	$U_{bus}$	320	320	320	320
Rated voltage motor [V <sub>rms</sub> ]	$U_{mot}$	186.0	179.0	340.0	317.0
Rated power [W]	$P_n$	1,225	1,950	1,225	1,950
Rated torque [Nm]	$M_n$	3.9	3.4	3.9	3.4
Rated current per phase [A <sub>rms</sub> ]	$I_n$	4.7	7.20	2.6	4.3
<b>Stall torque [Nm]</b>	<b><math>M_0</math></b>	<b>4.2</b>	<b>4.2</b>	<b>4.2</b>	<b>4.2</b>
Stall current per phase [A <sub>rms</sub> ]	$I_0$	5.0	8.6	2.7	5.0
Peak torque [Nm]	$M_{max}$	10.5	10.5	10.5	10.5
Peak current [A <sub>rms</sub> ]	$I_{max}$	14.4	25.2	7.7	14.4
Maximum speed [rpm]	$n_{max}$	3,930	6,890	3,905	6,970
Voltage constant at 1.000 rpm [V <sub>rms</sub> ]	$k_e$	53.3	30.6	98.0	53.3
Torque constant [Nm / A <sub>rms</sub> ]	$k_t$	0.823	0.472	1.530	0.799
Winding resistance (2 phases) at 20 °C [Ω]	$R_{p-p}$	3.0	1.0	10.1	3.0
Winding inductance (2 phases) [mH]	$L_{p-p}$	9.0	2.8	29.2	9.0
Electrical time constant [ms]	$t_{el}$	3.0	3.0	2.9	3.0
Thermal time constant [min]	$t_{th}$	30	30	30	30
Moment of inertia rotor [kg-cm <sup>2</sup> ]	J	1.46E+00	1.46E+00	1.46E+00	1.46E+00
Weight of motor [kg]	m	3.3	3.3	3.3	3.3

For standstill / rated current greater than 30 A, observe connection technology (Page 78) and encoder selection (Page 76)!  
Other voltage variants available on request.  
All nominal values with resolver.

## Performance

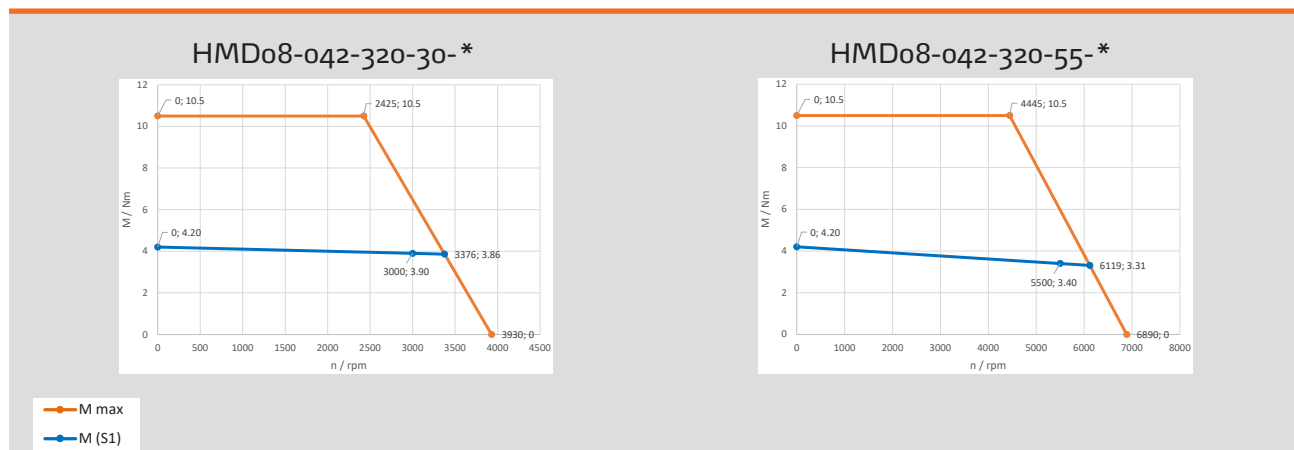

## Dimensions

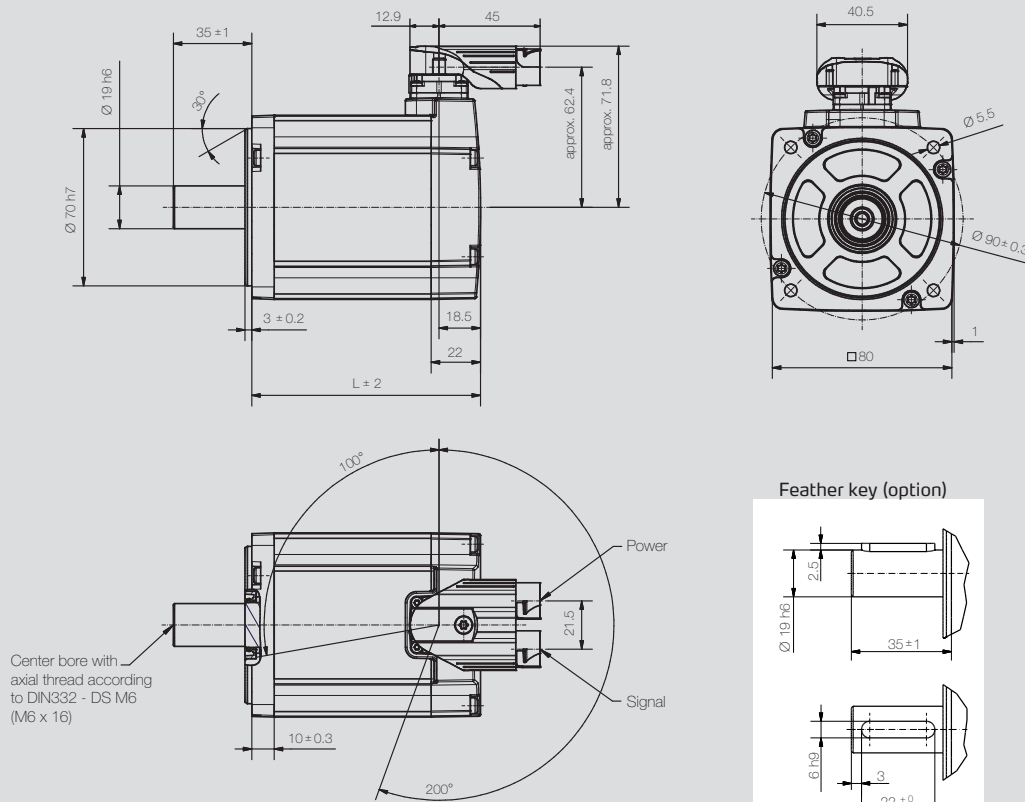

HMD08

Motor	L [mm] with encoder category 1*		L [mm] with encoder category 2*	
	without brake	with brake	without brake	with brake
HMD08-042	138 mm	186.5 mm	160 mm	208.5 mm

\* Encoder category 1: Resolver, SEK/SEL37, HESx/HENx, AM 34; only for variants with  $U_{bus} = 320/560 V_{DC}$   
Encoder category 2: Remaining encoders

HMD08-042-560-30-\*

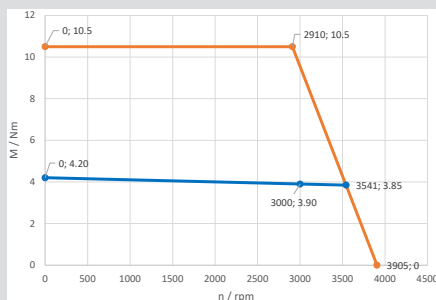

HMD08-042-560-55-\*

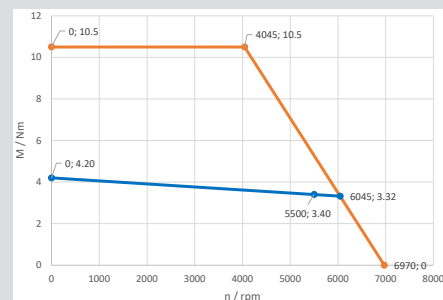

# ■ HMD08-057

## 48 V



## Specifications

		HMD08-057
Rated speed [rpm]	$n_n$	3,000
Number of pole pairs		5
Wiring of the motor winding		Y
DC bus voltage [ $V_{DC}$ ]	$U_{bus}$	48
Rated voltage motor [ $V_{rms}$ ]	$U_{mot}$	24.8
Rated power [W] <sup>1)</sup>	$P_n$	1,665
Rated torque [Nm]	$M_n$	5.3
Rated current per phase [ $A_{rms}$ ]	$I_n$	54.8
<b>Stall torque [Nm]</b>	<b><math>M_0</math></b>	<b>5.7</b>
Stall current per phase [ $A_{rms}$ ]	$I_0$	47.7
Peak torque [Nm]	$M_{max}$	14.3
Peak current [ $A_{rms}$ ]	$I_{max}$	139.0
Maximum speed [rpm]	$n_{max}$	4,100
Voltage constant at 1.000 rpm [ $V_{rms}$ ]	$k_e$	7.5
Torque constant [Nm / $A_{rms}$ ]	$k_t$	0.116
Winding resistance (2 phases) at 20 °C [ $\Omega$ ]	$R_{p-p}$	0.03
Winding inductance (2 phases) [mH]	$L_{p-p}$	0.1
Electrical time constant [ms]	$t_{el}$	3.3
Thermal time constant [min]	$t_{th}$	30
Moment of inertia rotor [kg-cm <sup>2</sup> ]	J	2.12E+00
Weight of motor [kg]	m	4.4

For standstill / rated current greater than 30 A, observe connection technology (Page 78) and encoder selection (Page 76)!  
Other voltage variants available on request.  
All nominal values with resolver.

## Performance

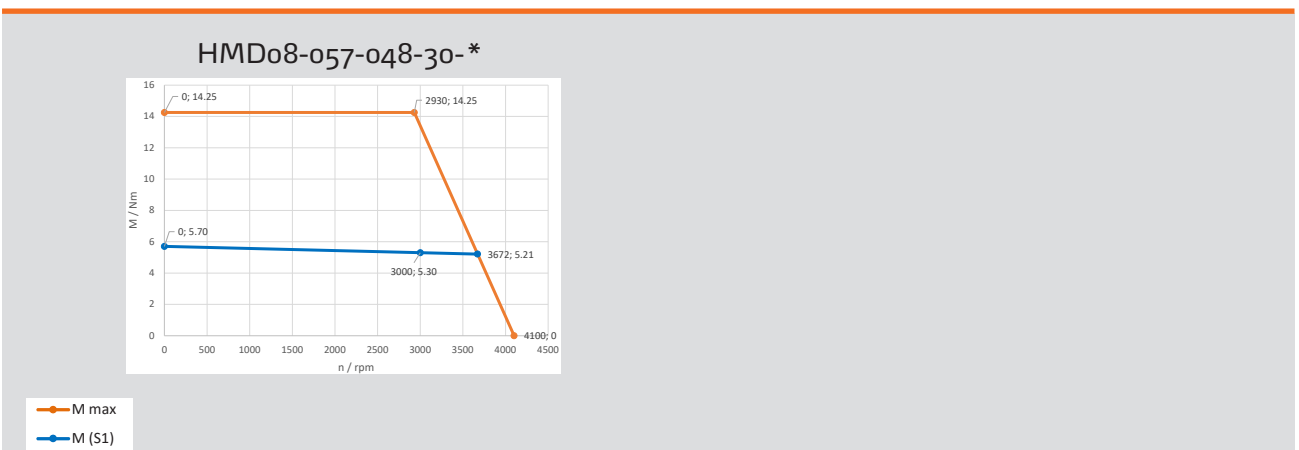

<sup>1)</sup> For UL approval, an S1 characteristic curve deviating by approx. 15 % applies. The specifications on the nameplates correspond to the UL values..

## Dimensions

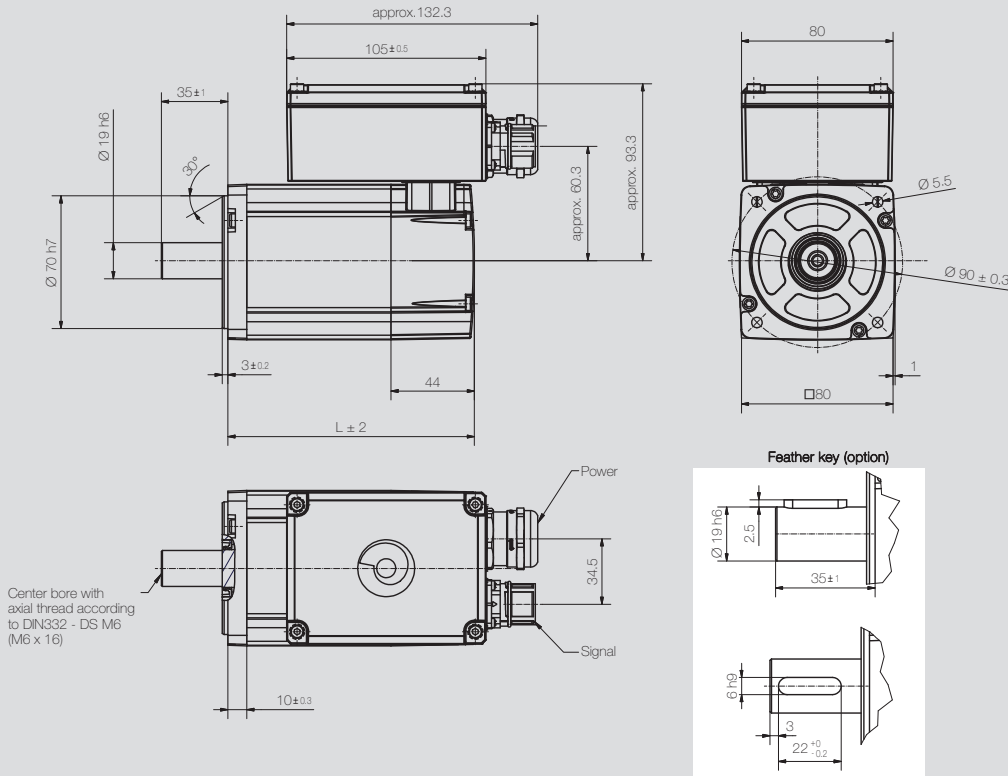

HMD08

Motor	L [mm] with encoder category 2*	
	without brake	with brake
HMD08-057	190 mm	238.5 mm

# ■ HMD08-057

## 320 / 560 V



## Specifications

HMD08-057

Rated speed [rpm]	$n_n$	3,000	5,500	3,000	5,500
Number of pole pairs		5	5	5	5
Wiring of the motor winding		Y	Y	Y	Y
DC bus voltage [V <sub>DC</sub> ]	$U_{bus}$	320	320	560	560
Rated voltage motor [V <sub>rms</sub> ]	$U_{mot}$	182.0	181.0	341.0	311.0
Rated power [W]	$P_n$	1,665	2,480	1,665	2,480
Rated torque [Nm]	$M_n$	5.3	4.3	5.3	4.3
Rated current per phase [A <sub>rms</sub> ]	$I_n$	6.1	8.8	3.3	5.1
<b>Stall torque [Nm]</b>	<b><math>M_0</math></b>	<b>5.7</b>	<b>5.7</b>	<b>5.7</b>	<b>5.7</b>
Stall current per phase [A <sub>rms</sub> ]	$I_0$	6.5	11.2	3.4	6.5
Peak torque [Nm]	$M_{max}$	14.3	14.3	14.3	14.3
Peak current [A <sub>rms</sub> ]	$I_{max}$	18.0	31.0	9.6	18.0
Maximum speed [rpm]	$n_{max}$	3,735	6,360	3,585	6,740
Voltage constant at 1.000 rpm [V <sub>rms</sub> ]	$k_e$	54.8	32.2	103.0	54.9
Torque constant [Nm / A <sub>rms</sub> ]	$k_t$	0.864	0.491	1.630	0.846
Winding resistance (2 phases) at 20 °C [Ω]	$R_{p-p}$	1.7	0.6	6.2	1.8
Winding inductance (2 phases) [mH]	$L_{p-p}$	6.0	2.0	20.7	6.0
Electrical time constant [ms]	$t_{el}$	3.4	3.3	3.2	3.4
Thermal time constant [min]	$t_{th}$	30	30	30	30
Moment of inertia rotor [kg-cm <sup>2</sup> ]	J	2.12E+00	2.12E+00	2.12E+00	2.12E+00
Weight of motor [kg]	m	4.4	4.4	4.4	4.4

For standstill / rated current greater than 30 A, observe connection technology (Page 78) and encoder selection (Page 76)!  
Other voltage variants available on request.  
All nominal values with resolver.

## Performance

HMD08-057-320-30-\*

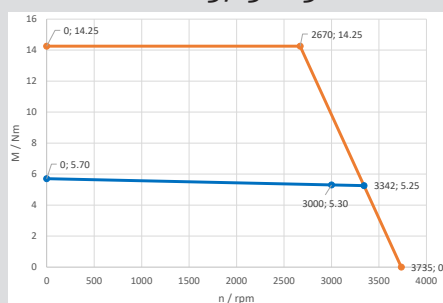

HMD08-057-320-55-\*

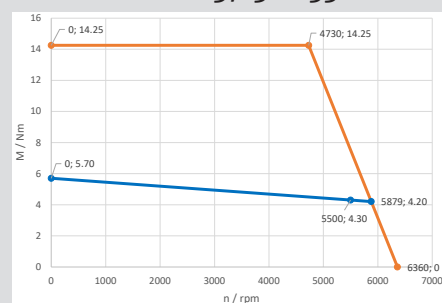

— M max  
— M (S1)

## Dimensions

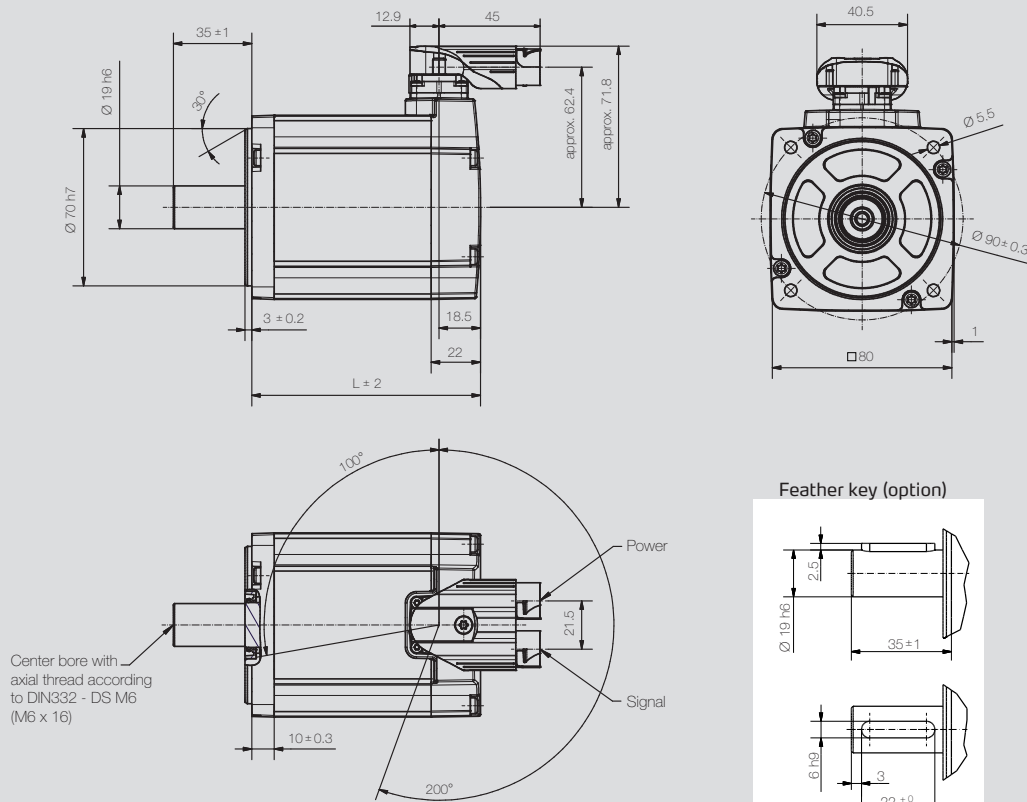

HMD08

Motor	L [mm] with encoder category 1*		L [mm] with encoder category 2*	
	without brake	with brake	without brake	with brake
HMD08-057	168 mm	216.5 mm	190 mm	238.5 mm

\* Encoder category 1: Resolver, SEK/SEL37, HESx/HENx, AM 34; only for variants with  $U_{bus} = 320/560 V_{DC}$   
Encoder category 2: Remaining encoders

HMD08-057-560-30-\*

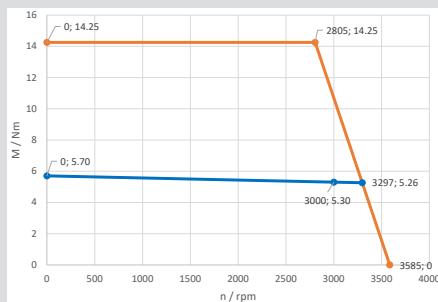

HMD08-057-560-55-\*

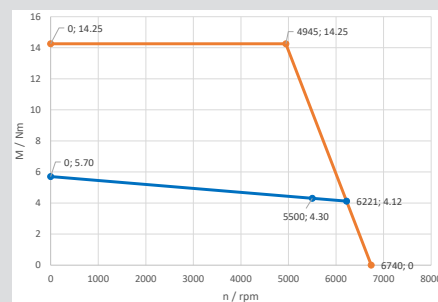

# HMD10-039

## 48 V



## Specifications

HMD10-039

Rated speed [rpm]	$n_n$	3,000	5,000
Number of pole pairs		5	5
Wiring of the motor winding		Y	Y
DC bus voltage [V <sub>DC</sub> ]	$U_{bus}$	48	48
Rated voltage motor [V <sub>rms</sub> ]	$U_{mot}$	23.5	23.4
Rated power [W] <sup>1)</sup>	$P_n$	1,130	1,675
Rated torque [Nm]	$M_n$	3.6	3.2
Rated current per phase [A <sub>rms</sub> ]	$I_n$	32.9	48.5
<b>Stall torque [Nm]</b>	<b><math>M_0</math></b>	<b>3.9</b>	<b>3.9</b>
Stall current per phase [A <sub>rms</sub> ]	$I_0$	34.6	56.0
Peak torque [Nm]	$M_{max}$	9.8	9.8
Peak current [A <sub>rms</sub> ]	$I_{max}$	86.5	140.0
Maximum speed [rpm]	$n_{max}$	4,390	7,090
Voltage constant at 1,000 rpm [V <sub>rms</sub> ]	$k_e$	7.1	4.4
Torque constant [Nm / A <sub>rms</sub> ]	$k_t$	0.11	0.07
Winding resistance (2 phases) at 20 °C [Ω]	$R_{p-p}$	0.056	0.021
Winding inductance (2 phases) [mH]	$L_{p-p}$	0.16	0.062
Electrical time constant [ms]	$t_{el}$	2.9	3.0
Thermal time constant [min]	$t_{th}$	30	30
Moment of inertia rotor [kg-cm <sup>2</sup> ]	$J$	1.94E+00	1.94E+00
Weight of motor [kg]	$m$	4.5	4.5

All nominal values with resolver.

## Performance

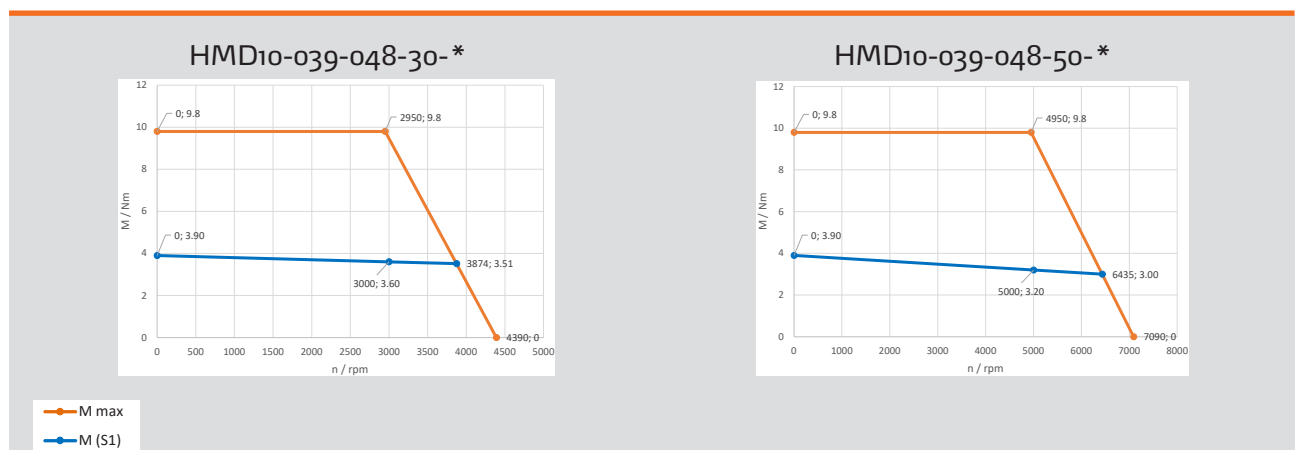

<sup>1)</sup> For UL approval, an S1 characteristic curve deviating by approx. 15 % applies. The specifications on the nameplates correspond to the UL values..

## Dimensions

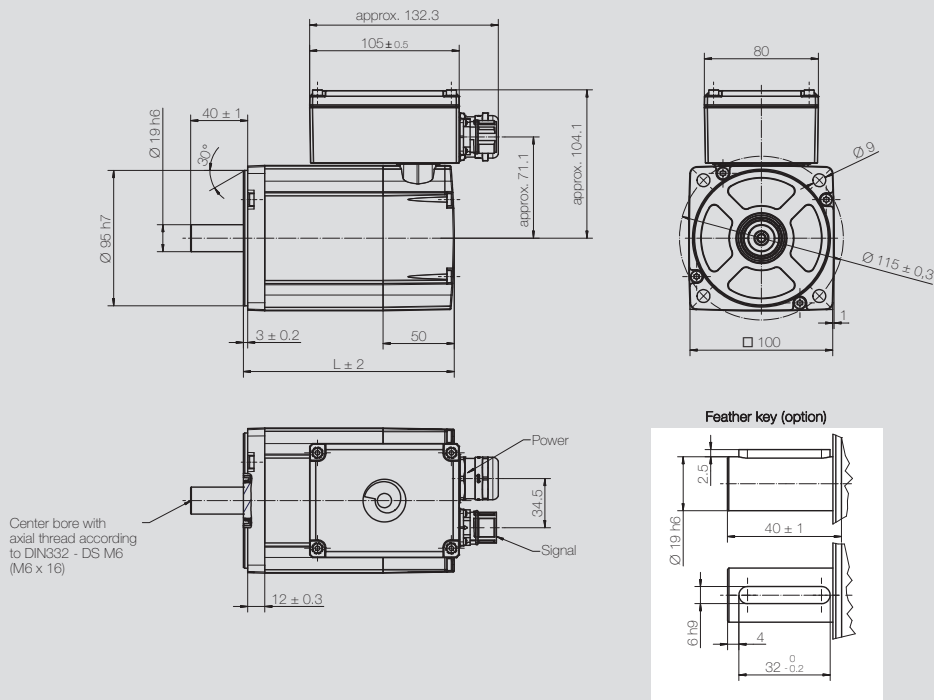

HMD10

Motor	L [mm]	
	without brake	with brake
HMD10-039	145 mm	192 mm

# HMD10-039

320 / 560 V



## Specifications

		HMD10-039			
Rated speed [rpm]	$n_n$	3,000	5,000	3,000	5,000
Number of pole pairs		5	5	5	5
Wiring of the motor winding		Y	Y	Y	Y
DC bus voltage [V <sub>DC</sub> ]	$U_{bus}$	320	320	560	560
Rated voltage motor [V <sub>rms</sub> ]	$U_{mot}$	163	162	289	263
Rated power [W]	$P_n$	1,130	1,675	1,130	1,675
Rated torque [Nm]	$M_n$	3.6	3.2	3.6	3.2
Rated current per phase [A <sub>rms</sub> ]	$I_n$	4.7	7.0	2.7	4.3
<b>Stall torque [Nm]</b>	<b><math>M_0</math></b>	<b>3.9</b>	<b>3.9</b>	<b>3.9</b>	<b>3.9</b>
Stall current per phase [A <sub>rms</sub> ]	$I_0$	5.0	8.2	2.8	5.0
Peak torque [Nm]	$M_{max}$	9.8	9.8	9.8	9.8
Peak current [A <sub>rms</sub> ]	$I_{max}$	12.5	20.5	7.0	12.5
Maximum speed [rpm]	$n_{max}$	4,280	6,860	4,190	7,490
Voltage constant at 1,000 rpm [V <sub>rms</sub> ]	$k_e$	49.2	30.7	88.0	49.2
Torque constant [Nm / A <sub>rms</sub> ]	$k_t$	0.77	0.46	1.33	0.74
Winding resistance (2 phases) at 20 °C [Ω]	$R_{p-p}$	2.6	1.02	8.4	2.6
Winding inductance (2 phases) [mH]	$L_{p-p}$	7.8	2.9	24.4	7.8
Electrical time constant [ms]	$t_{el}$	3.0	2.9	2.9	3.0
Thermal time constant [min]	$t_{th}$	30	30	30	30
Moment of inertia rotor [kg-cm <sup>2</sup> ]	J	1.94E+00	1.94E+00	1.94E+00	1.94E+00
Weight of motor [kg]	m	4.5	4.5	4.5	4.5

All nominal values with resolver.

## Performance

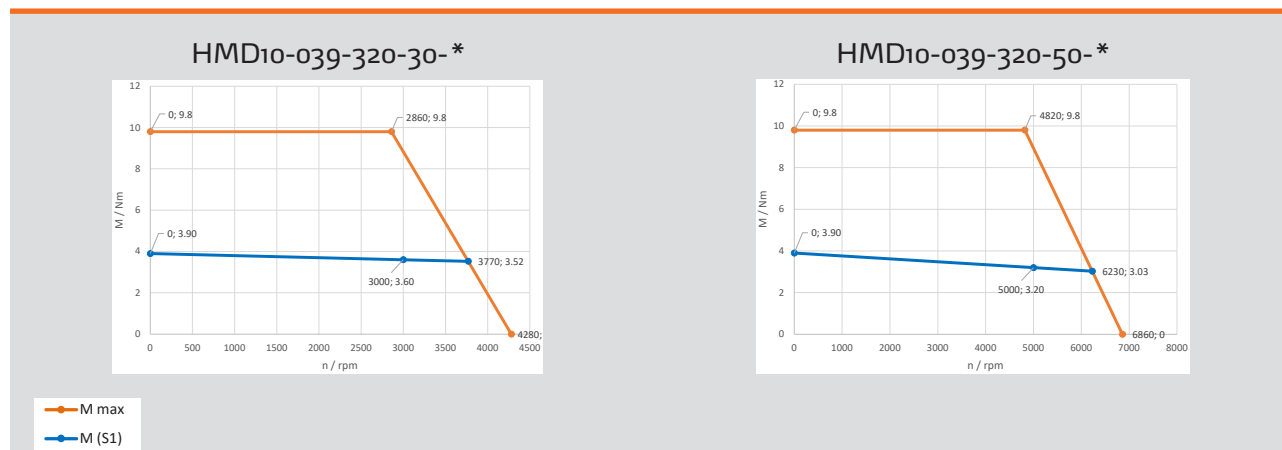

## Dimensions

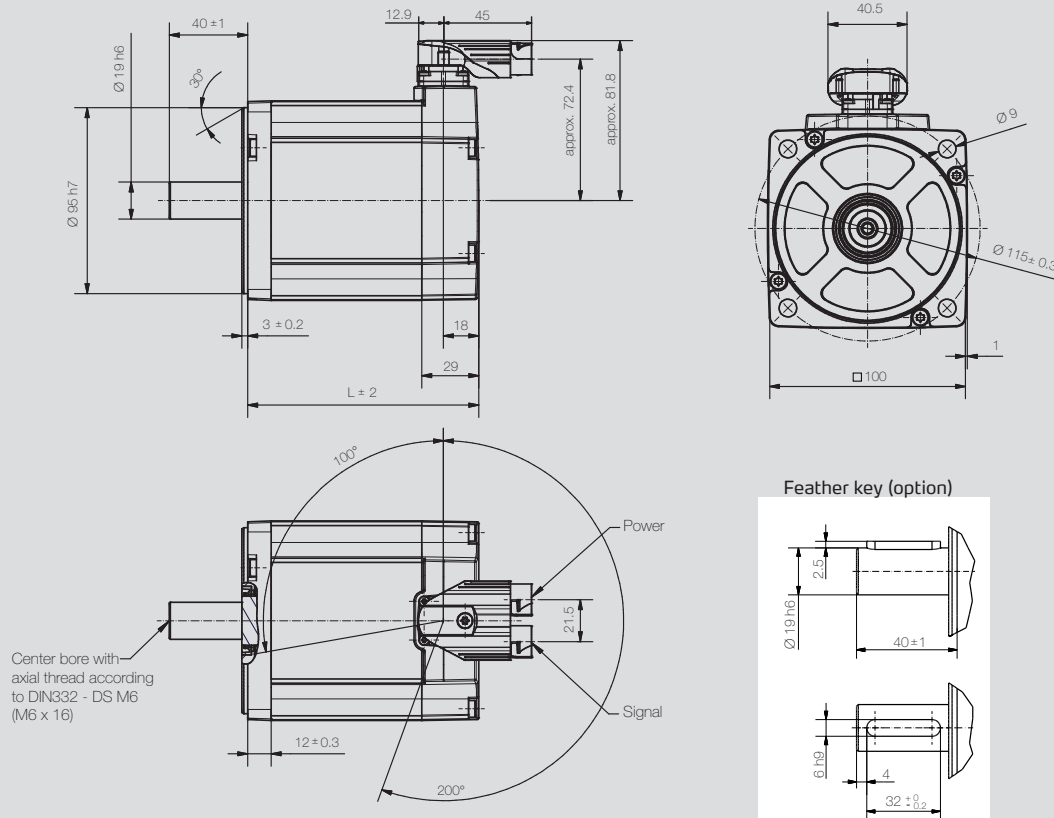

HMD10

Motor	L [mm] with encoder category 1*		L [mm] with encoder category 2*	
	without brake	with brake	without brake	with brake
HMD10-039	124 mm	171 mm	145 mm	192 mm

\* Encoder category 1: Resolver, SEK/SEL37, HESx/HEMx, AM 34; only for variants with  $U_{bus} = 320/560 V_{DC}$   
Encoder category 2: Remaining encoders

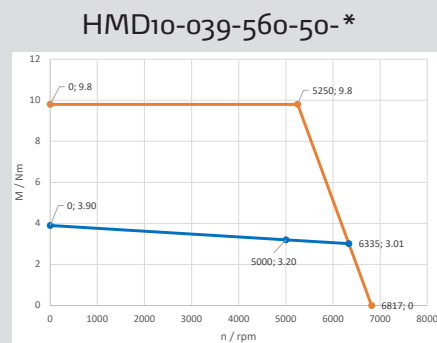
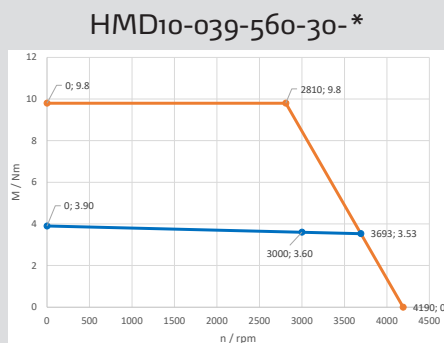

# HMD10-057

## 48 V



## Specifications

HMD10-057

Rated speed [rpm]	$n_n$	3,000	5,000
Number of pole pairs		5	5
Wiring of the motor winding		Y	Y
DC bus voltage [V <sub>DC</sub> ]	$U_{bus}$	48	48
Rated voltage motor [V <sub>rms</sub> ]	$U_{mot}$	24.9	26.5
Rated power [W] <sup>1)</sup>	$P_n$	1,635	2,095
Rated torque [Nm]	$M_n$	5.2	4.0
Rated current per phase [A <sub>rms</sub> ]	$I_n$	44.4	53.3
<b>Stall torque [Nm]</b>	<b><math>M_0</math></b>	<b>5.7</b>	<b>5.7</b>
Stall current per phase [A <sub>rms</sub> ]	$I_0$	47.1	70.6
Peak torque [Nm]	$M_{max}$	14.3	14.3
Peak current [A <sub>rms</sub> ]	$I_{max}$	117.8	176.5
Maximum speed [rpm]	$n_{max}$	4,100	6,110
Voltage constant at 1,000 rpm [V <sub>rms</sub> ]	$k_e$	7.6	5.1
Torque constant [Nm / A <sub>rms</sub> ]	$k_t$	0.12	0.08
Winding resistance (2 phases) at 20 °C [Ω]	$R_{p-p}$	0.04	0.017
Winding inductance (2 phases) [mH]	$L_{p-p}$	0.12	0.054
Electrical time constant [ms]	$t_{el}$	3.0	3.2
Thermal time constant [min]	$t_{th}$	30	30
Moment of inertia rotor [kg-cm <sup>2</sup> ]	$J$	2.75E+00	2.75E+00
Weight of motor [kg]	$m$	5.0	5.0

All nominal values with resolver.

## Performance

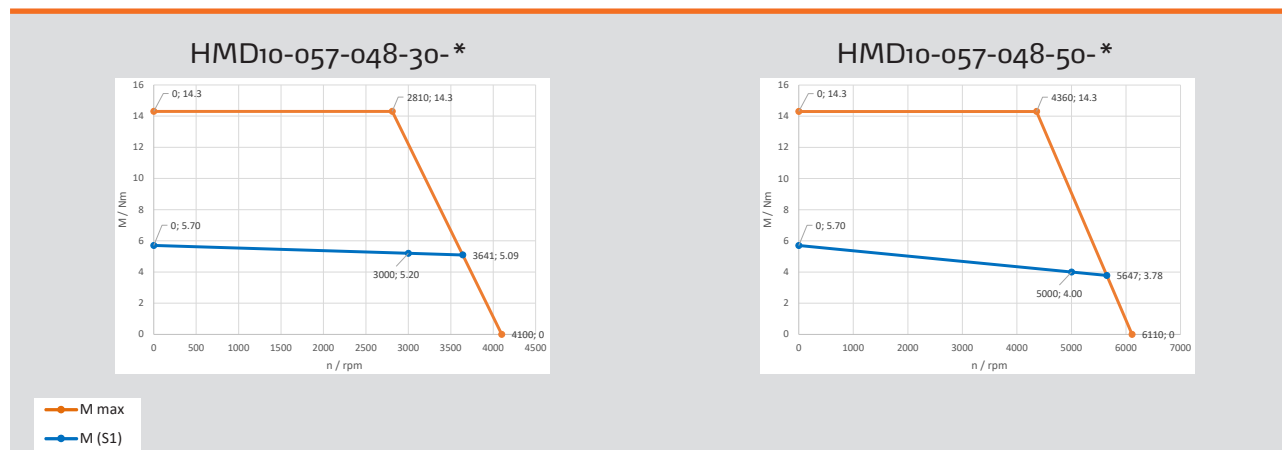

<sup>1)</sup> For UL approval, an S1 characteristic curve deviating by approx. 15 % applies. The specifications on the nameplates correspond to the UL values..

## Dimensions

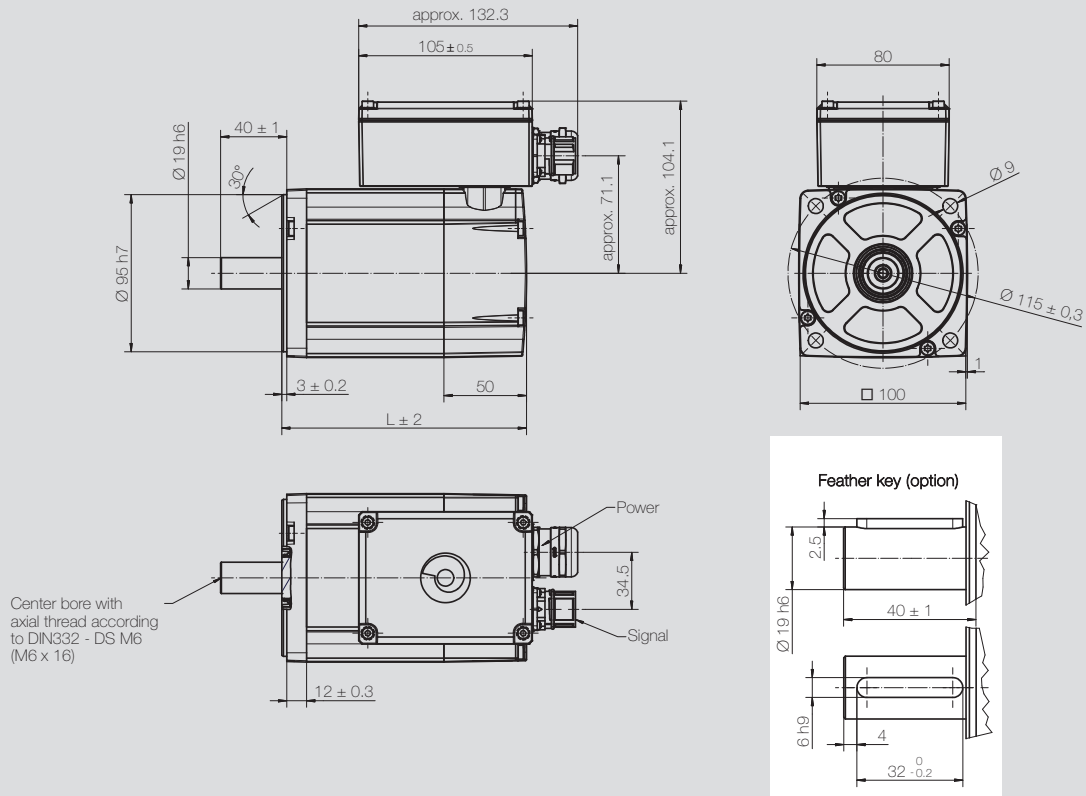

HMD10

Motor	L [mm]	
	without brake	with brake
HMD10-057	160 mm	207 mm

# HMD10-057

320 / 560 V



## Specifications

HMD10-057

Rated speed [rpm]	$n_n$	3,000	5,000	3,000	5,000
Number of pole pairs		5	5	5	5
Wiring of the motor winding		Y	Y	Y	Y
DC bus voltage [V <sub>DC</sub> ]	$U_{bus}$	320	320	560	560
Rated voltage motor [V <sub>rms</sub> ]	$U_{mot}$	177	182	323	284
Rated power [W]	$P_n$	1,635	2,095	1,635	2,095
Rated torque [Nm]	$M_n$	5.2	4.0	5.2	4.0
Rated current per phase [A <sub>rms</sub> ]	$I_n$	6.1	7.6	3.4	4.8
<b>Stall torque [Nm]</b>	<b><math>M_0</math></b>	<b>5.7</b>	<b>5.7</b>	<b>5.7</b>	<b>5.7</b>
Stall current per phase [A <sub>rms</sub> ]	$I_0$	6.5	10.2	3.6	6.5
Peak torque [Nm]	$M_{max}$	14.3	14.3	14.3	14.3
Peak current [A <sub>rms</sub> ]	$I_{max}$	16.3	25.5	9.0	16.3
Maximum speed [rpm]	$n_{max}$	3,790	6,020	3,650	6,630
Voltage constant at 1,000 rpm [V <sub>rms</sub> ]	$k_e$	55.6	35.0	101.1	55.6
Torque constant [Nm / A <sub>rms</sub> ]	$k_t$	0.85	0.53	1.53	0.83
Winding resistance (2 phases) at 20 °C [Ω]	$R_{p-p}$	1.72	0.70	5.6	1.72
Winding inductance (2 phases) [mH]	$L_{p-p}$	5.5	2.2	18.2	5.5
Electrical time constant [ms]	$t_{el}$	3.2	3.1	3.3	3.2
Thermal time constant [min]	$t_{th}$	30	30	30	30
Moment of inertia rotor [kg-cm <sup>2</sup> ]	$J$	2.75E+00	2.75E+00	2.75E+00	2.75E+00
Weight of motor [kg]	$m$	5.0	5.0	5.0	5.0

All nominal values with resolver.

## Performance

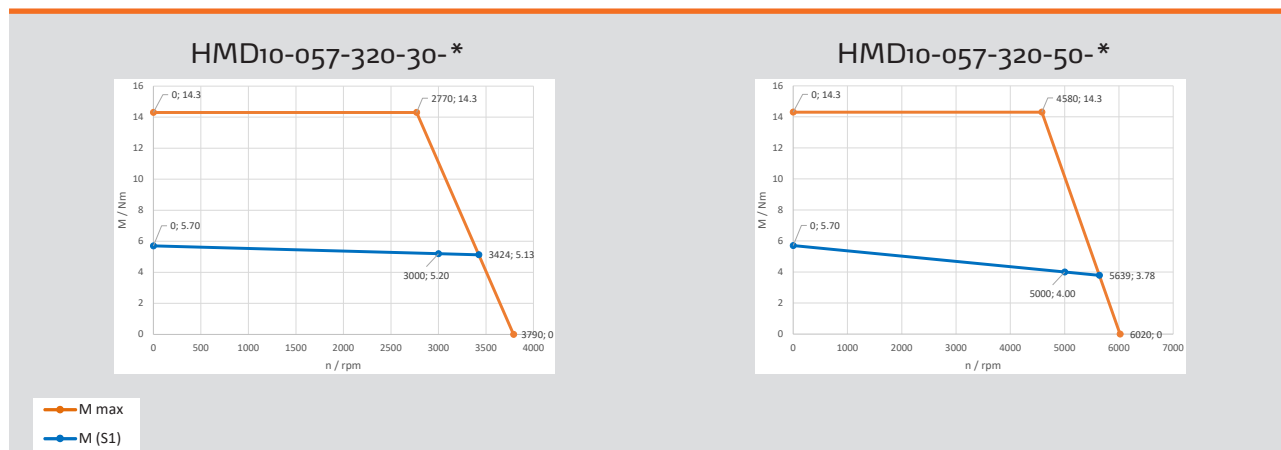

## Dimensions

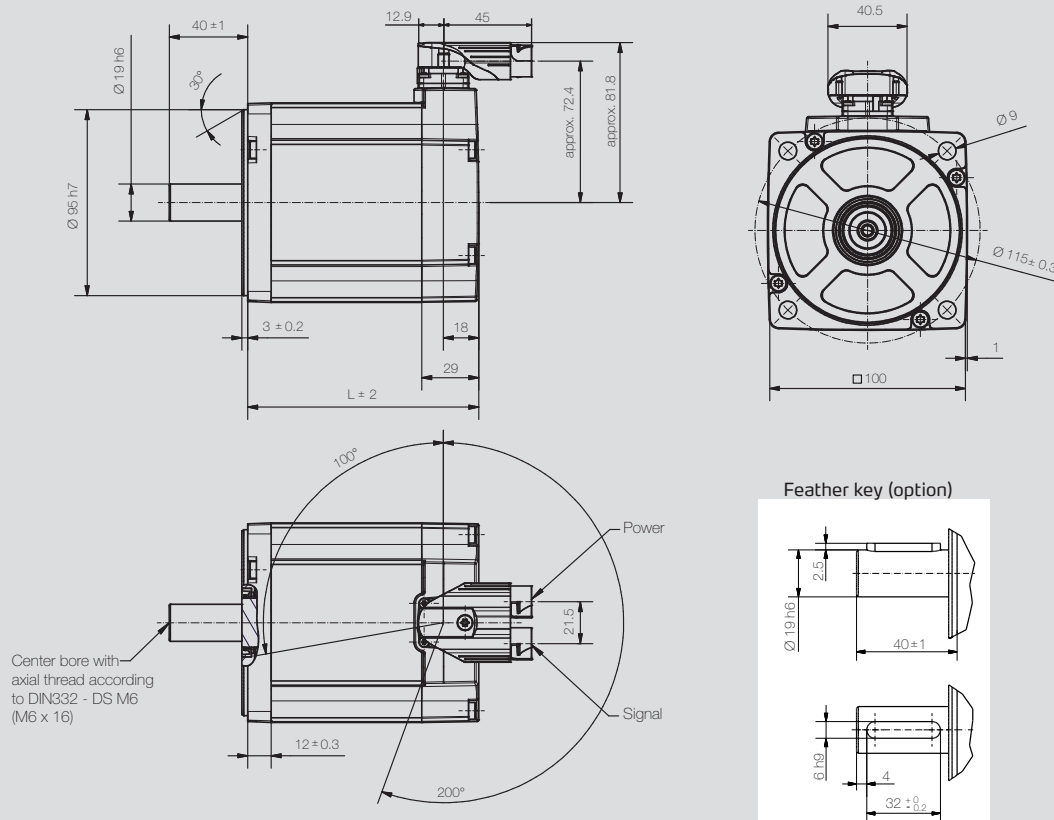

HMD10

Motor	L [mm] with encoder category 1*		L [mm] with encoder category 2*	
	without brake	with brake	without brake	with brake
HMD10-057	139 mm	186 mm	160 mm	207 mm

\* Encoder category 1: Resolver, SEK/SEL37, HESx/HEMx, AM 34; only for variants with  $U_{bus} = 320/560 V_{DC}$   
Encoder category 2: Remaining encoders

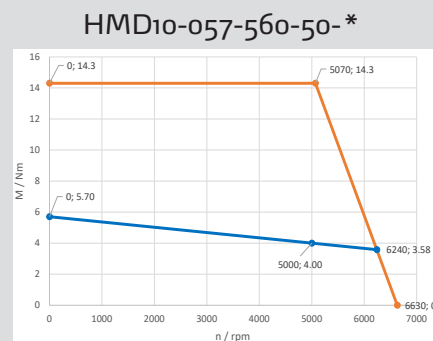
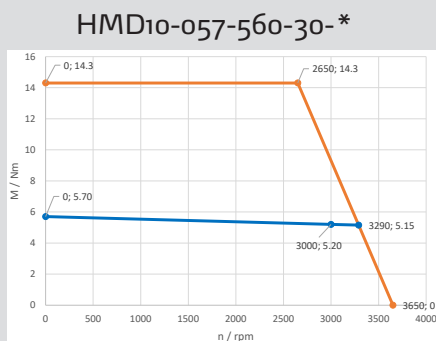

# HMD10-076

## 48 V



## Specifications

HMD10-076

Rated speed [rpm]	$n_n$	3,000
Number of pole pairs		5
Wiring of the motor winding		Y
DC bus voltage [V <sub>DC</sub> ]	$U_{bus}$	48
Rated voltage motor [V <sub>rms</sub> ]	$U_{mot}$	26.6
Rated power [W] <sup>1)</sup>	$P_n$	2,000
Rated torque [Nm]	$M_n$	6.5
Rated current per phase [A <sub>rms</sub> ]	$I_n$	50.3
<b>Stall torque [Nm]</b>	<b><math>M_0</math></b>	<b>7.6</b>
Stall current per phase [A <sub>rms</sub> ]	$I_0$	57.7
Peak torque [Nm]	$M_{max}$	19.0
Peak current [A <sub>rms</sub> ]	$I_{max}$	144.3
Maximum speed [rpm]	$n_{max}$	3,710
Voltage constant at 1,000 rpm [V <sub>rms</sub> ]	$k_e$	8.4
Torque constant [Nm / A <sub>rms</sub> ]	$k_t$	0.13
Winding resistance (2 phases) at 20 °C [Ω]	$R_{p-p}$	0.025
Winding inductance (2 phases) [mH]	$L_{p-p}$	0.098
Electrical time constant [ms]	$t_{el}$	3.8
Thermal time constant [min]	$t_{th}$	35
Moment of inertia rotor [kg-cm <sup>2</sup> ]	$J$	3.57E+00
Weight of motor [kg]	$m$	5.5

All nominal values with resolver.

## Performance

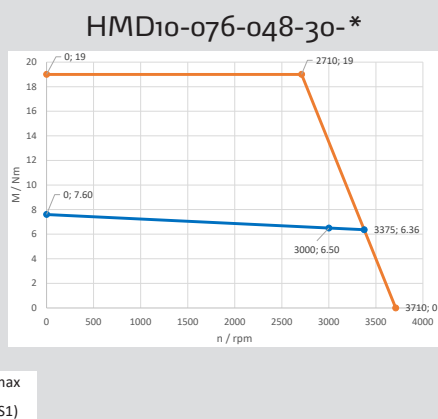

<sup>1)</sup> For UL approval, an S1 characteristic curve deviating by approx. 15 % applies. The specifications on the nameplates correspond to the UL values..

## Dimensions

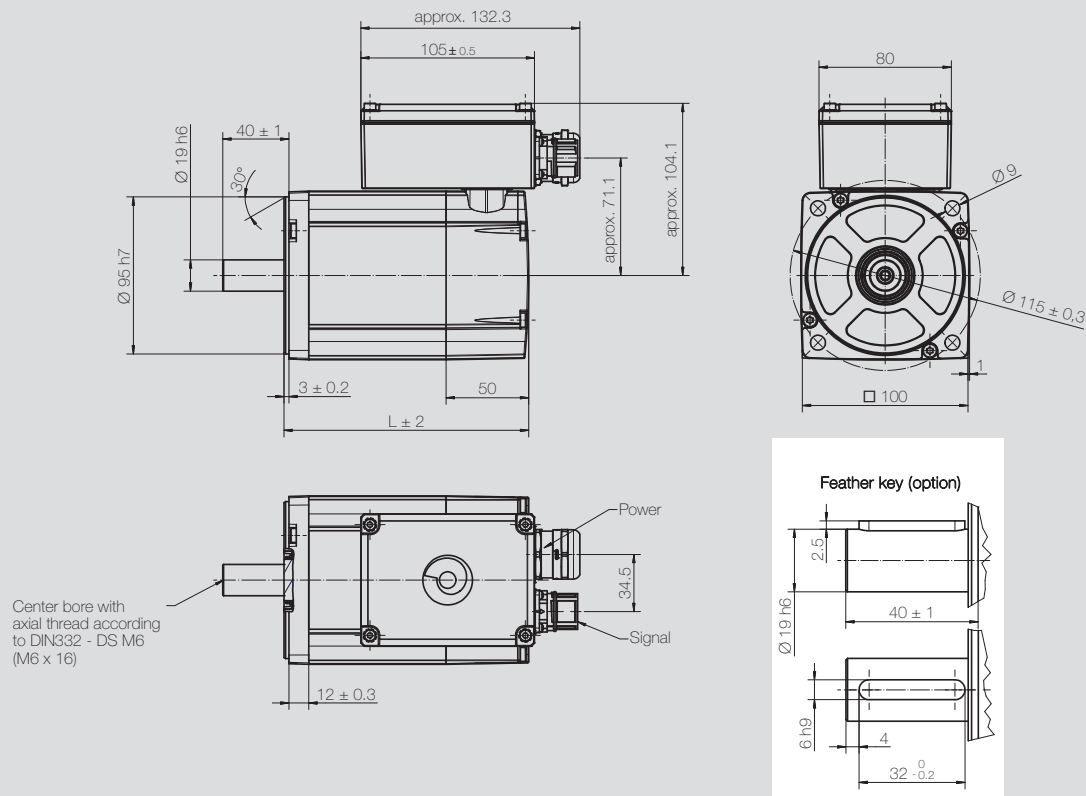

Motor	L [mm]	
	without brake	with brake
HMD10-076	175 mm	222 mm

HMD10

# HMD10-076

320 / 560 V



## Specifications

HMD10-076

Rated speed [rpm]	$n_n$	3,000	5,000	3,000	5,000
Number of pole pairs		5	5	5	5
Wiring of the motor winding		Y	Y	Y	Y
DC bus voltage [V <sub>DC</sub> ]	$U_{bus}$	320	320	560	560
Rated voltage motor [V <sub>rms</sub> ]	$U_{mot}$	166	176	315	268
Rated power [W]	$P_n$	2,000	2,500	2,000	2,500
Rated torque [Nm]	$M_n$	6.5	4.8	6.5	4.8
Rated current per phase [A <sub>rms</sub> ]	$I_n$	8.0	9.4	4.3	6.3
<b>Stall torque [Nm]</b>	<b><math>M_0</math></b>	<b>7.6</b>	<b>7.6</b>	<b>7.6</b>	<b>7.6</b>
Stall current per phase [A <sub>rms</sub> ]	$I_0$	9.1	13.5	4.9	9.1
Peak torque [Nm]	$M_{max}$	19.0	19.0	19.0	19.0
Peak current [A <sub>rms</sub> ]	$I_{max}$	22.8	33.8	12.3	22.8
Maximum speed [rpm]	$n_{max}$	3,950	6,020	3,720	6,920
Voltage constant at 1,000 rpm [V <sub>rms</sub> ]	$k_e$	53.3	35.0	99.0	53.3
Torque constant [Nm / A <sub>rms</sub> ]	$k_t$	0.81	0.51	1.51	0.76
Winding resistance (2 phases) at 20 °C [Ω]	$R_{p-p}$	1.03	0.44	3.4	1.03
Winding inductance (2 phases) [mH]	$L_{p-p}$	3.64	1.6	13.0	3.64
Electrical time constant [ms]	$t_{el}$	3.6	3.6	3.8	3.6
Thermal time constant [min]	$t_{th}$	35	35	35	35
Moment of inertia rotor [kg-cm <sup>2</sup> ]	$J$	3.57E+00	3.57E+00	3.57E+00	3.57E+00
Weight of motor [kg]	$m$	5.5	5.5	5.5	5.5

All nominal values with resolver.

## Performance

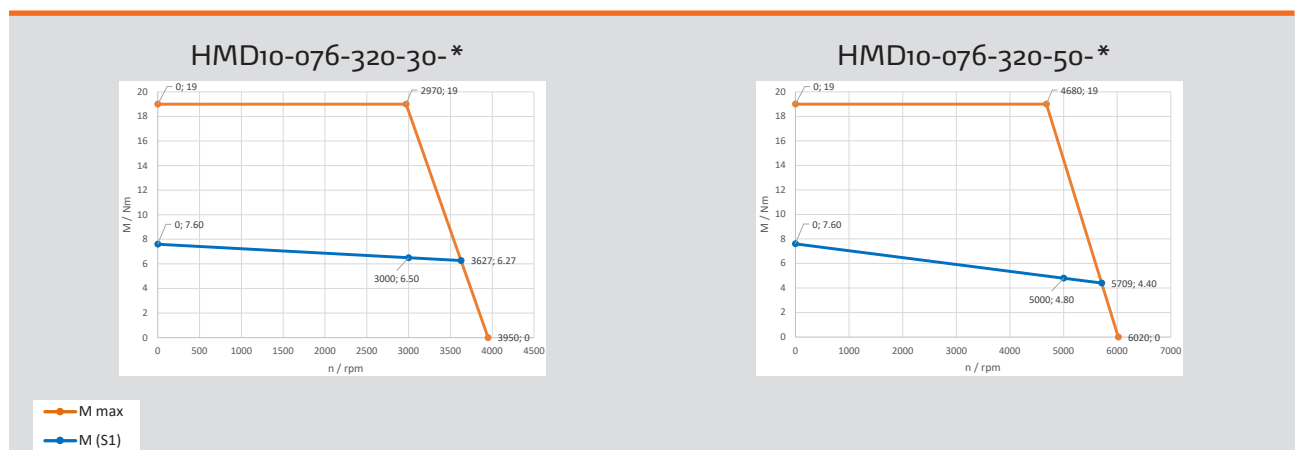

## Dimensions

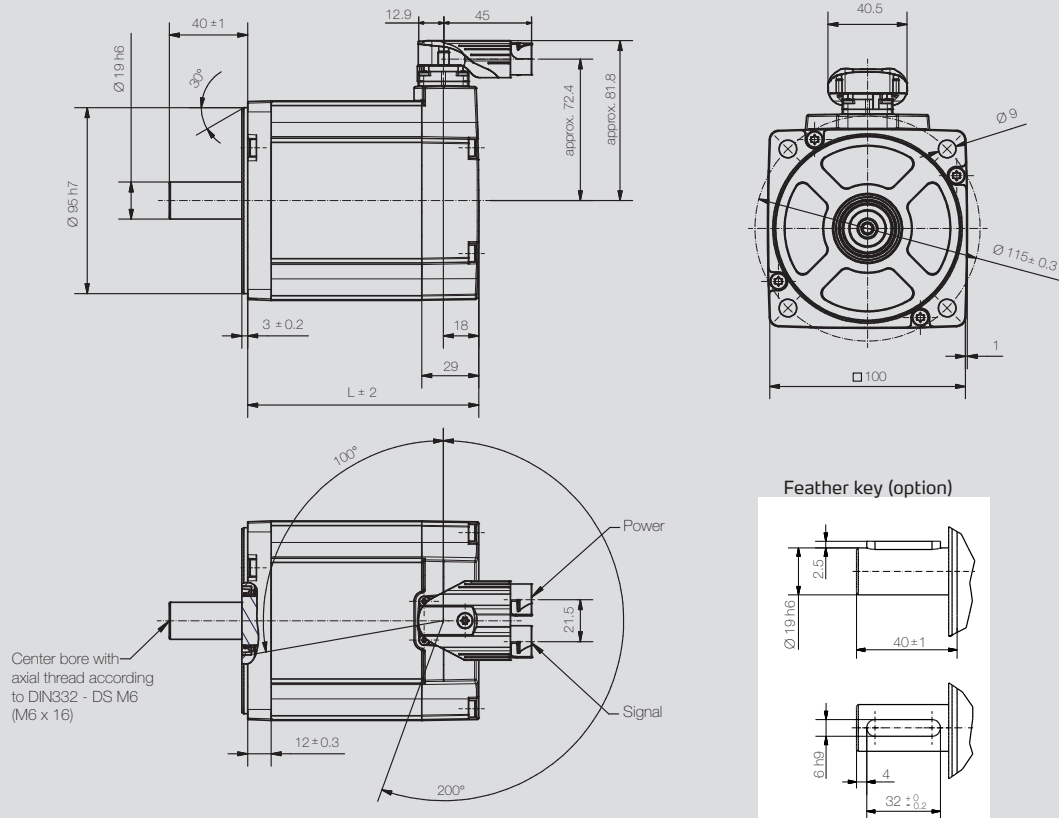

HMD10

Motor	L [mm] with encoder category 1*		L [mm] with encoder category 2*	
	without brake	with brake	without brake	with brake
HMD10-076	154 mm	201 mm	175 mm	222 mm

\* Encoder category 1: Resolver, SEK/SEL37, HESx/HEMx, AM 34; only for variants with  $U_{\text{bus}} = 320/560 \text{ VDC}$   
Encoder category 2: Remaining encoders

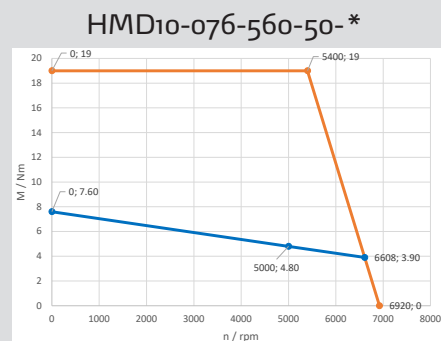
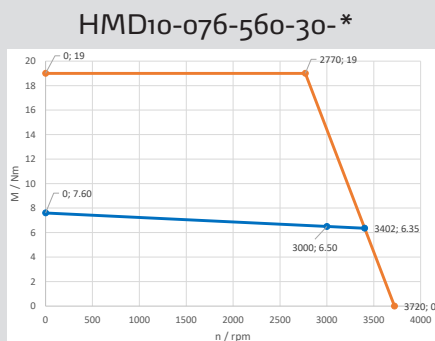

# HMD10-105

## 48 V



## Specifications

HMD10-105

Rated speed [rpm]	$n_n$	3,000
Number of pole pairs		5
Wiring of the motor winding		Y
DC bus voltage [V <sub>DC</sub> ]	$U_{bus}$	48
Rated voltage motor [V <sub>rms</sub> ]	$U_{mot}$	25
Rated power [W] <sup>1)</sup>	$P_n$	2,700
Rated torque [Nm]	$M_n$	8.6
Rated current per phase [A <sub>rms</sub> ]	$I_n$	70.6
<b>Stall torque [Nm]</b>	<b><math>M_0</math></b>	<b>10.5</b>
Stall current per phase [A <sub>rms</sub> ]	$I_0$	82.3
Peak torque [Nm]	$M_{max}$	26.3
Peak current [A <sub>rms</sub> ]	$I_{max}$	205.8
Maximum speed [rpm]	$n_{max}$	3,850
Voltage constant at 1,000 rpm [V <sub>rms</sub> ]	$k_e$	8.1
Torque constant [Nm / A <sub>rms</sub> ]	$k_t$	0.12
Winding resistance (2 phases) at 20 °C [Ω]	$R_{p-p}$	0.014
Winding inductance (2 phases) [mH]	$L_{p-p}$	0.057
Electrical time constant [ms]	$t_{el}$	4.07
Thermal time constant [min]	$t_{th}$	35
Moment of inertia rotor [kg-cm <sup>2</sup> ]	$J$	5.21E+00
Weight of motor [kg]	$m$	6.5

All nominal values with resolver.

## Performance

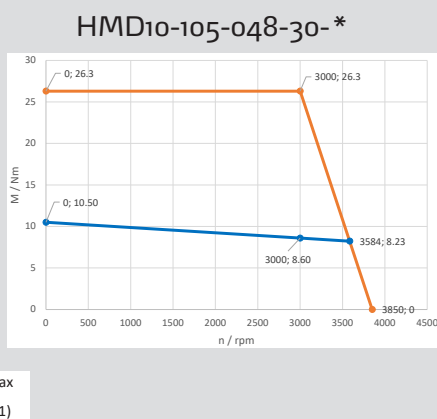

<sup>1)</sup> For UL approval, an S1 characteristic curve deviating by approx. 15 % applies. The specifications on the nameplates correspond to the UL values..

## Dimensions

**HMD10**

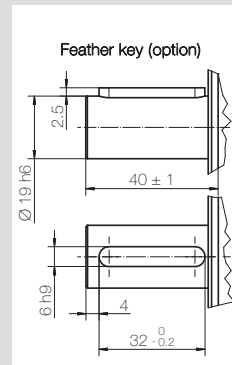
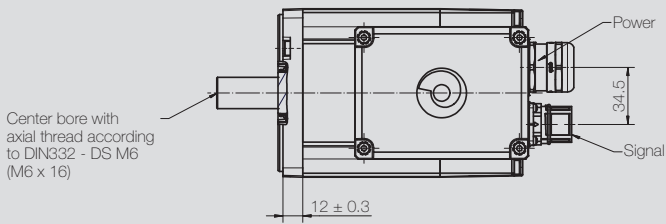
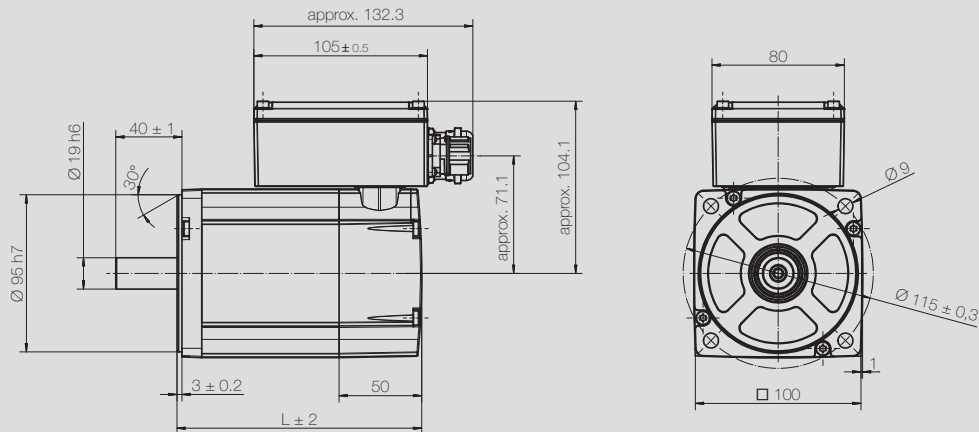

Motor	L [mm]	
	without brake	with brake
HMD10-105	205 mm	252 mm

# HMD10-105

320 / 560 V



## Specifications

HMD10-105

Rated speed [rpm]	$n_n$	3,000	5,000	3,000	5,000
Number of pole pairs		5	5	5	5
Wiring of the motor winding		Y	Y	Y	Y
DC bus voltage [V <sub>DC</sub> ]	$U_{bus}$	320	320	560	560
Rated voltage motor [V <sub>rms</sub> ]	$U_{mot}$	186	184	321	299
Rated power [W]	$P_n$	2,700	2,900	2,700	2,900
Rated torque [Nm]	$M_n$	8.6	5.5	8.6	5.5
Rated current per phase [A <sub>rms</sub> ]	$I_n$	9.5	10.6	5.5	6.5
<b>Stall torque [Nm]</b>	<b><math>M_0</math></b>	<b>10.5</b>	<b>10.5</b>	<b>10.5</b>	<b>10.5</b>
Stall current per phase [A <sub>rms</sub> ]	$I_0$	11.0	18.0	6.4	11.0
Peak torque [Nm]	$M_{max}$	26.3	26.3	26.3	26.3
Peak current [A <sub>rms</sub> ]	$I_{max}$	27.5	45.0	16.0	27.5
Maximum speed [rpm]	$n_{max}$	3,480	5,660	3,520	6,090
Voltage constant at 1,000 rpm [V <sub>rms</sub> ]	$k_e$	60.5	37.2	104.8	60.5
Torque constant [Nm / A <sub>rms</sub> ]	$k_t$	0.91	0.52	1.56	0.85
Winding resistance (2 phases) at 20 °C [Ω]	$R_{p-p}$	0.77	0.29	2.3	0.77
Winding inductance (2 phases) [mH]	$L_{p-p}$	3.2	1.2	9.4	3.2
Electrical time constant [ms]	$t_{el}$	4.2	4.1	4.1	4.2
Thermal time constant [min]	$t_{th}$	35	35	35	35
Moment of inertia rotor [kg-cm <sup>2</sup> ]	$J$	5.21E+00	5.21E+00	5.21E+00	5.21E+00
Weight of motor [kg]	$m$	6.5	6.5	6.5	6.5

All nominal values with resolver.

## Performance

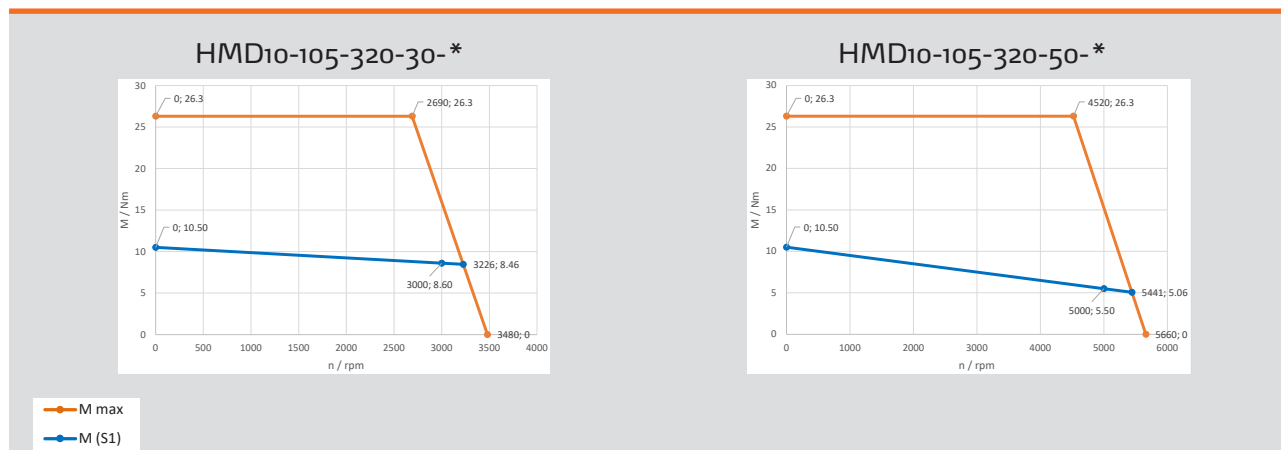

## Dimensions

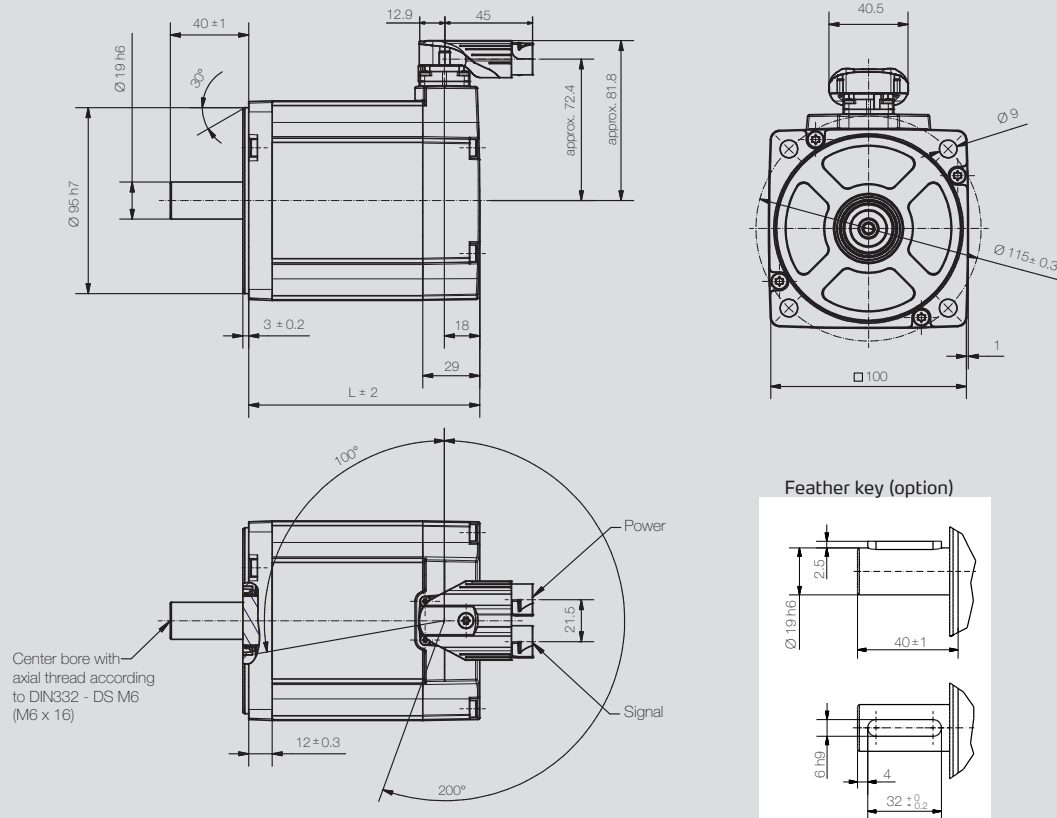

**HMD10**

Motor	L [mm] with encoder category 1*		L [mm] with encoder category 2*	
	without brake	with brake	without brake	with brake
HMD10-105	184 mm	231 mm	205 mm	252 mm

\* Encoder category 1: Resolver, SEK/SEL37, HESx/HEMx, AM 34; only for variants with  $U_{bus} = 320/560$  VDC  
Encoder category 2: Remaining encoders

HMD10-105-560-30-\*

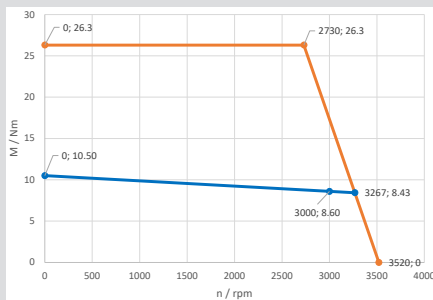

HMD10-105-560-50-\*

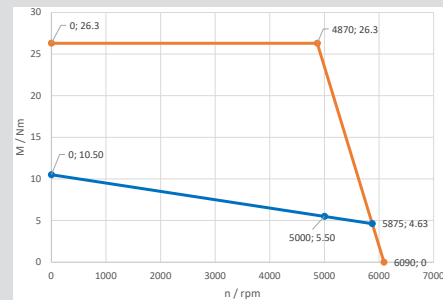

# HMD13-133



## Specifications

HMD13-133

Rated speed [rpm]	$n_n$	2,000	3,600
Number of pole pairs		5	5
Wiring of the motor winding		Y	Y
DC bus voltage [V <sub>DC</sub> ]	$U_{bus}$	560	560
Rated voltage motor [V <sub>rms</sub> ]	$U_{mot}$	326	331
Rated power [W]	$P_n$	2,400	3,400
Rated torque [Nm]	$M_n$	11.5	9.0
Rated current per phase [A <sub>rms</sub> ]	$I_n$	4.8	6.3
<b>Stall torque [Nm]</b>	<b><math>M_0</math></b>	<b>13.3</b>	<b>13.3</b>
Stall current per phase [A <sub>rms</sub> ]	$I_0$	5.5	9.3
Peak torque [Nm]	$M_{max}$	33.3	33.3
Peak current [A <sub>rms</sub> ]	$I_{max}$	13.8	23.1
Maximum speed [rpm]	$n_{max}$	2,340	4,040
Voltage constant at 1,000 rpm [V <sub>rms</sub> ]	$k_e$	157.7	91.2
Torque constant [Nm / A <sub>rms</sub> ]	$k_t$	2.42	1.43
Winding resistance (2 phases) at 20 °C [Ω]	$R_{p-p}$	2.67	0.812
Winding inductance (2 phases) [mH]	$L_{p-p}$	25.04	6.96
Electrical time constant [ms]	$t_{el}$	9.4	8.6
Thermal time constant [min]	$t_{th}$	42	42
Moment of inertia rotor [kg-cm <sup>2</sup> ]	$J$	8.21E+00	8.21E+00
Weight of motor [kg]	$m$	8.4	8.4

All nominal values with resolver.

## Performance

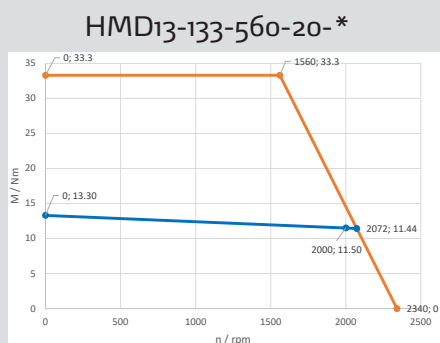

— M max  
— M (S1)

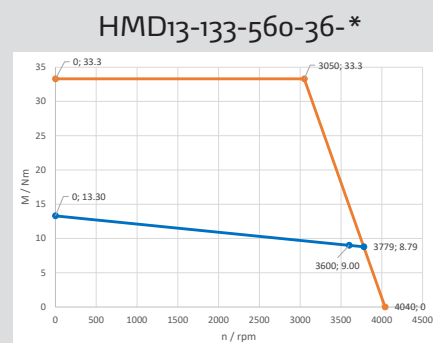

## Dimensions

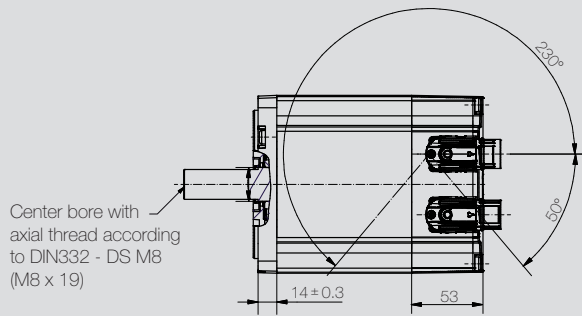
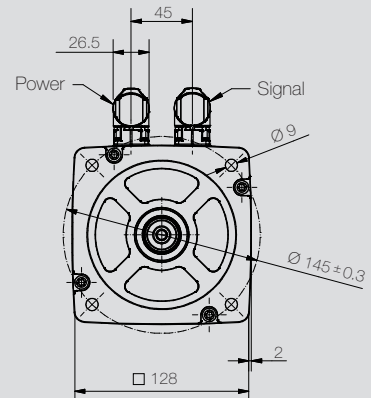
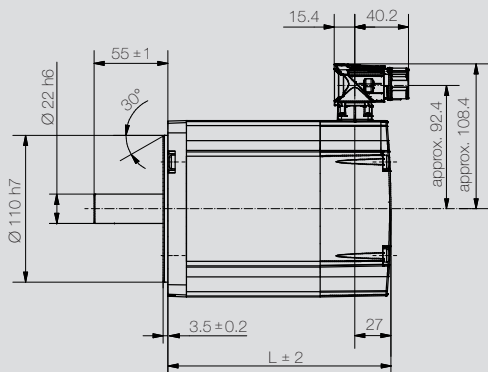

Feather key (option)

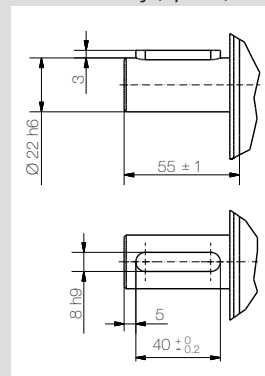

L [mm]

without brake	with brake
185 mm	223 mm

HMD13

# HMD13-190



## Specifications

HMD13-190

Rated speed [rpm]	$n_n$	2,000	3,600
Number of pole pairs		5	5
Wiring of the motor winding		Y	Y
DC bus voltage [V <sub>DC</sub> ]	$U_{bus}$	560	560
Rated voltage motor [V <sub>rms</sub> ]	$U_{mot}$	330	316
Rated power [W]	$P_n$	3,350	4,200
Rated torque [Nm]	$M_n$	16.0	11.2
Rated current per phase [A <sub>rms</sub> ]	$I_n$	6.3	8.2
<b>Stall torque [Nm]</b>	<b><math>M_0</math></b>	<b>19.0</b>	<b>19.0</b>
Stall current per phase [A <sub>rms</sub> ]	$I_0$	7.5	13.7
Peak torque [Nm]	$M_{max}$	47.5	47.5
Peak current [A <sub>rms</sub> ]	$I_{max}$	18.8	34.3
Maximum speed [rpm]	$n_{max}$	2,280	4,210
Voltage constant at 1,000 rpm [V <sub>rms</sub> ]	$k_e$	161.9	87.5
Torque constant [Nm / A <sub>rms</sub> ]	$k_t$	2.54	1.37
Winding resistance (2 phases) at 20 °C [Ω]	$R_{p-p}$	1.50	0.440
Winding inductance (2 phases) [mH]	$L_{p-p}$	15.25	4.5
Electrical time constant [ms]	$t_{el}$	10.3	10.2
Thermal time constant [min]	$t_{th}$	49	49
Moment of inertia rotor [kg-cm <sup>2</sup> ]	$J$	1.20E+01	1.20E+01
Weight of motor [kg]	$m$	11.0	11.0

All nominal values with resolver.

## Performance

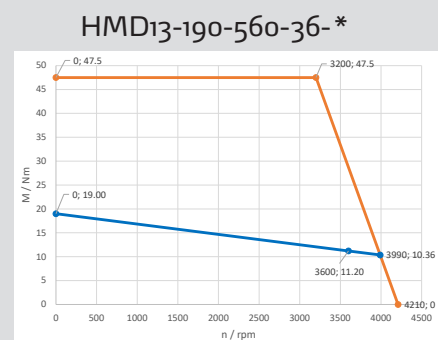
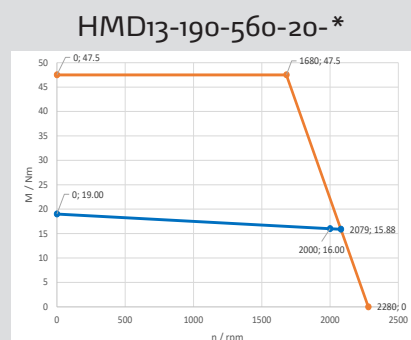

—●— M max  
—●— M (S1)

## Dimensions

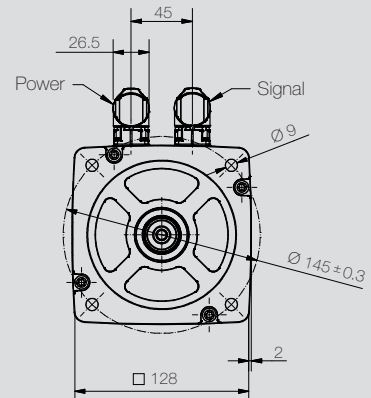
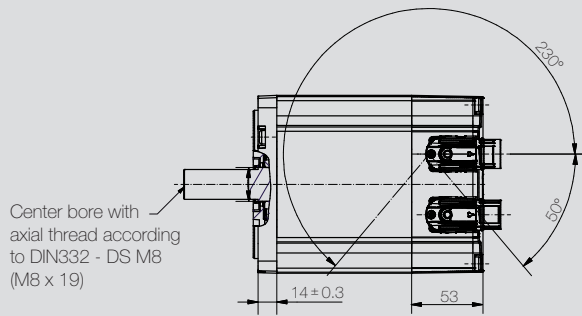
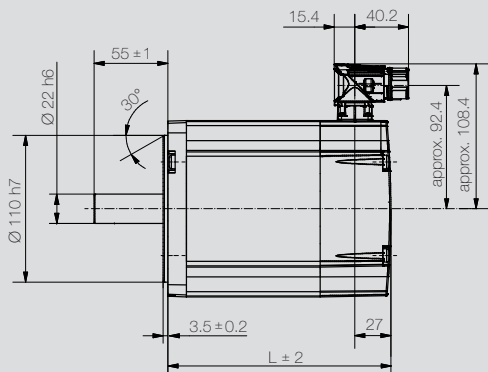

Feather key (option)

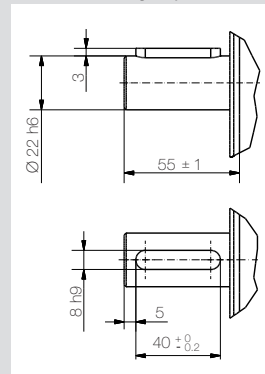

L [mm]	
without brake	with brake
215 mm	253 mm

**HMD13**

# HMD13-245



## Specifications

HMD13-245

Rated speed [rpm]	$n_n$	2,000	3,600
Number of pole pairs		5	5
Wiring of the motor winding		Y	Y
DC bus voltage [V <sub>DC</sub> ]	$U_{bus}$	560	560
Rated voltage motor [V <sub>rms</sub> ]	$U_{mot}$	327	322
Rated power [W]	$P_n$	4,300	5,000
Rated torque [Nm]	$M_n$	20.5	13.3
Rated current per phase [A <sub>rms</sub> ]	$I_n$	8.2	9.6
<b>Stall torque [Nm]</b>	<b><math>M_0</math></b>	<b>24.5</b>	<b>24.5</b>
Stall current per phase [A <sub>rms</sub> ]	$I_0$	9.7	17.1
Peak torque [Nm]	$M_{max}$	61.3	61.3
Peak current [A <sub>rms</sub> ]	$I_{max}$	24.3	42.8
Maximum speed [rpm]	$n_{max}$	2,320	4,120
Voltage constant at 1,000 rpm [V <sub>rms</sub> ]	$k_e$	158.7	89.5
Torque constant [Nm / A <sub>rms</sub> ]	$k_t$	2.50	1.39
Winding resistance (2 phases) at 20 °C [Ω]	$R_{p-p}$	1.08	0.340
Winding inductance (2 phases) [mH]	$L_{p-p}$	10.59	3.33
Electrical time constant [ms]	$t_{el}$	9.8	9.7
Thermal time constant [min]	$t_{th}$	49	49
Moment of inertia rotor [kg-cm <sup>2</sup> ]	$J$	1.58E+01	1.58E+01
Weight of motor [kg]	$m$	13.5	13.5

All nominal values with resolver.

## Performance

HMD13-245-560-20-\*

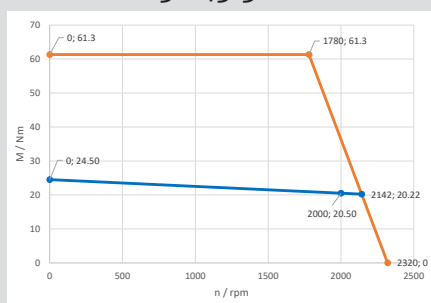

— M max  
— M (S1)

HMD13-245-560-36-\*

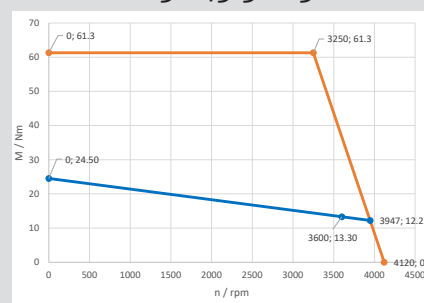

## Dimensions

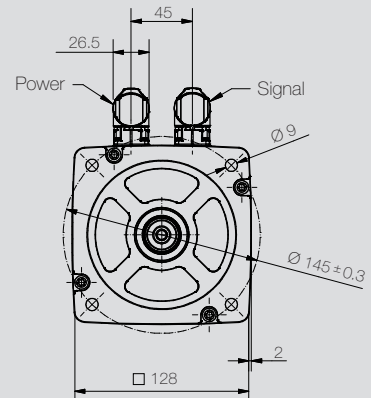
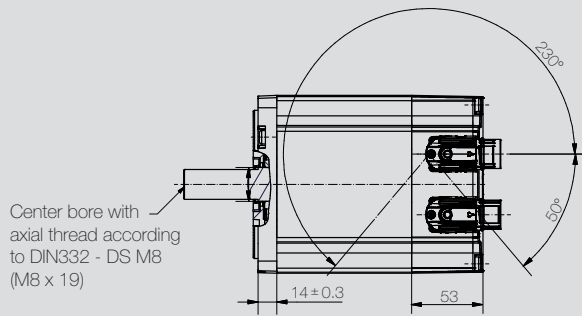
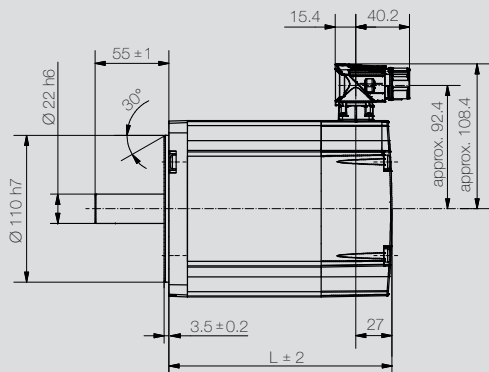

Feather key (option)

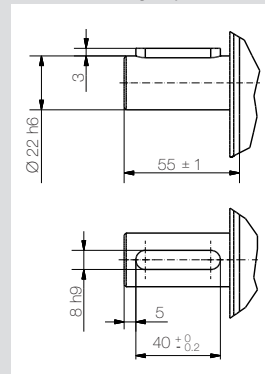

L [mm]	
without brake	with brake
245 mm	306 mm

**HMD13**

# HMD15-036



## Specifications

HMD15-036

Rated speed [rpm]	$n_n$	2,000	3,000
Number of pole pairs		5	5
Wiring of the motor winding		Y	Y
DC bus voltage [V <sub>DC</sub> ]	$U_{bus}$	560	560
Rated voltage motor [V <sub>rms</sub> ]	$U_{mot}$	314	307
Rated power [W]	$P_n$	5,850	6,600
Rated torque [Nm]	$M_n$	28.0	21.0
Rated current per phase [A <sub>rms</sub> ]	$I_n$	11.7	13.2
<b>Stall torque [Nm]</b>	<b><math>M_0</math></b>	<b>36.0</b>	<b>36.0</b>
Stall current per phase [A <sub>rms</sub> ]	$I_0$	15.1	22.6
Peak torque [Nm]	$M_{max}$	72.0	72.0
Peak current [A <sub>rms</sub> ]	$I_{max}$	30.2	45.2
Maximum speed [rpm]	$n_{max}$	2,430	3,640
Voltage constant at 1,000 rpm [V <sub>rms</sub> ]	$k_e$	152.0	101.4
Torque constant [Nm / A <sub>rms</sub> ]	$k_t$	2.39	1.59
Winding resistance (2 phases) at 20 °C [Ω]	$R_{p-p}$	0.560	0.250
Winding inductance (2 phases) [mH]	$L_{p-p}$	8.9	3.94
Electrical time constant [ms]	$t_{el}$	15.9	15.8
Thermal time constant [min]	$t_{th}$	45	45
Moment of inertia rotor [kg-cm <sup>2</sup> ]	$J$	3.87E+01	3.87E+01
Weight of motor [kg]	$m$	19.0	19.0

All nominal values with resolver.

## Performance

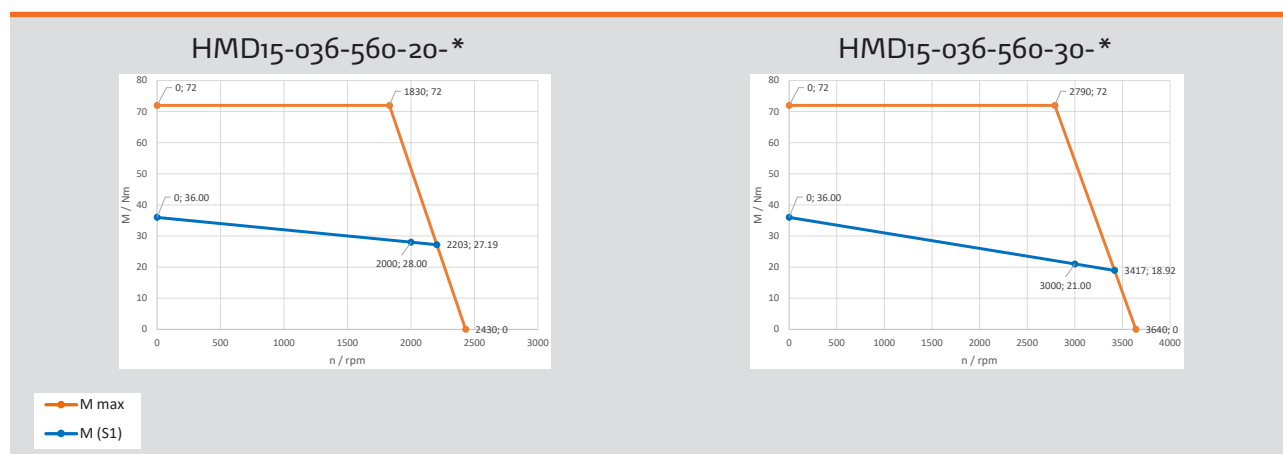

## Dimensions

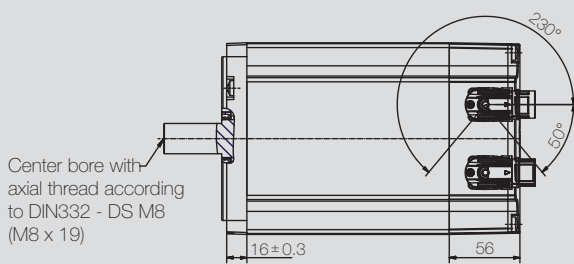
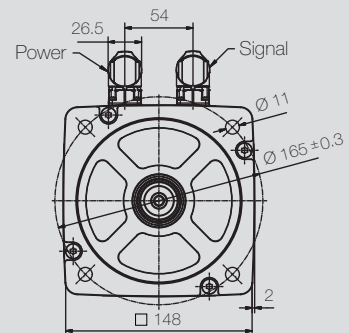
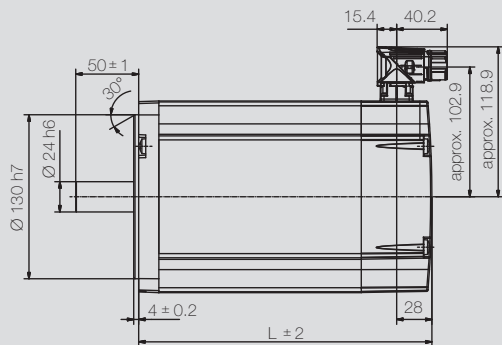

Feather key (option)

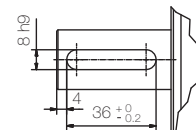
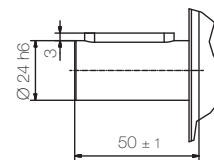

Motor	L [mm]	
	without brake	with brake
HMD15-036	260 mm	311 mm

HMD15

# HMD15-043



## Specifications

HMD15-043

Rated speed [rpm]	$n_n$	2,000	3,000
Number of pole pairs		5	5
Wiring of the motor winding		Y	Y
DC bus voltage [V <sub>DC</sub> ]	$U_{bus}$	560	560
Rated voltage motor [V <sub>rms</sub> ]	$U_{mot}$	307	313
Rated power [W]	$P_n$	6,800	7,850
Rated torque [Nm]	$M_n$	32.5	25.0
Rated current per phase [A <sub>rms</sub> ]	$I_n$	13.8	15.3
<b>Stall torque [Nm]</b>	<b><math>M_0</math></b>	<b>42.5</b>	<b>42.5</b>
Stall current per phase [A <sub>rms</sub> ]	$I_0$	18.0	26.0
Peak torque [Nm]	$M_{max}$	85.0	85.0
Peak current [A <sub>rms</sub> ]	$I_{max}$	36.0	52.0
Maximum speed [rpm]	$n_{max}$	2,460	3,560
Voltage constant at 1,000 rpm [V <sub>rms</sub> ]	$k_e$	149.8	103.7
Torque constant [Nm / A <sub>rms</sub> ]	$k_t$	2.36	1.63
Winding resistance (2 phases) at 20 °C [Ω]	$R_{p-p}$	0.41	0.2
Winding inductance (2 phases) [mH]	$L_{p-p}$	6.8	3.3
Electrical time constant [ms]	$t_{el}$	16.6	16.5
Thermal time constant [min]	$t_{th}$	50	50
Moment of inertia rotor [kg-cm <sup>2</sup> ]	$J$	4.82E+01	4.82E+01
Weight of motor [kg]	$m$	23.0	23.0

All nominal values with resolver.

## Performance

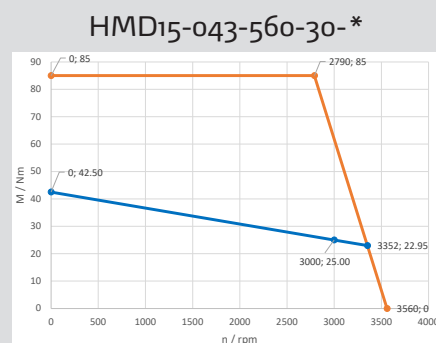
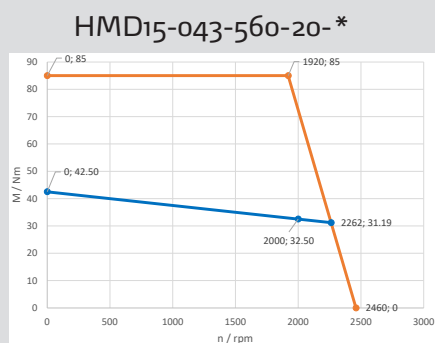

— M max  
— M (S1)

## Dimensions

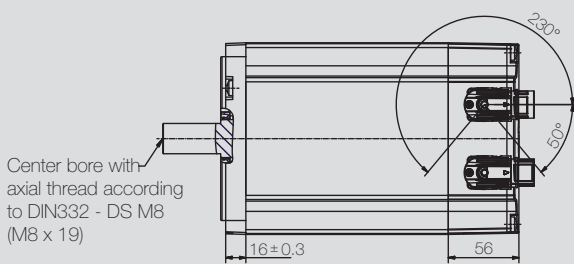
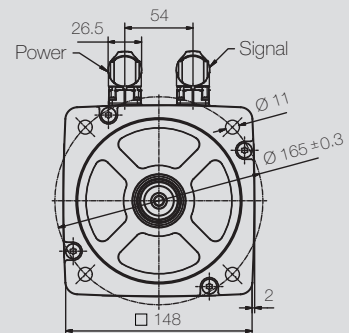
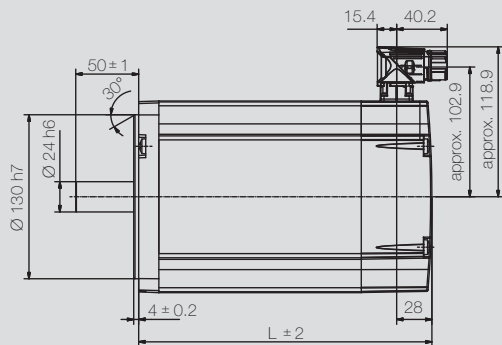

Feather key (option)

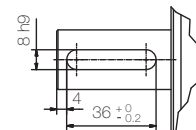
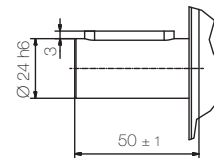

HMD15

Motor	L [mm]	
	without brake	with brake
HMD15-043	290 mm	341 mm

# HMD15-049



## Specifications

HMD15-049

Rated speed [rpm]	$n_n$	2,000	3,000
Number of pole pairs		5	5
Wiring of the motor winding		Y	Y
DC bus voltage [V <sub>DC</sub> ]	$U_{bus}$	560	560
Rated voltage motor [V <sub>rms</sub> ]	$U_{mot}$	311	313
Rated power [W]	$P_n$	7,750	9,110
Rated torque [Nm]	$M_n$	37.0	29.0
Rated current per phase [A <sub>rms</sub> ]	$I_n$	15.5	17.8
<b>Stall torque [Nm]</b>	<b><math>M_0</math></b>	<b>49.0</b>	<b>49.0</b>
Stall current per phase [A <sub>rms</sub> ]	$I_0$	20.4	30.0
Peak torque [Nm]	$M_{max}$	98.0	98.0
Peak current [A <sub>rms</sub> ]	$I_{max}$	40.8	60.0
Maximum speed [rpm]	$n_{max}$	2,430	3,560
Voltage constant at 1,000 rpm [V <sub>rms</sub> ]	$k_e$	152.0	103.7
Torque constant [Nm / A <sub>rms</sub> ]	$k_t$	2.39	1.63
Winding resistance (2 phases) at 20 °C [Ω]	$R_{p-p}$	0.348	0.160
Winding inductance (2 phases) [mH]	$L_{p-p}$	5.93	2.75
Electrical time constant [ms]	$t_{el}$	17.0	17.2
Thermal time constant [min]	$t_{th}$	55	55
Moment of inertia rotor [kg-cm <sup>2</sup> ]	$J$	5.76E+01	5.76E+01
Weight of motor [kg]	$m$	26.0	26.0

All nominal values with resolver.

## Performance

HMD15-049-560-20-\*

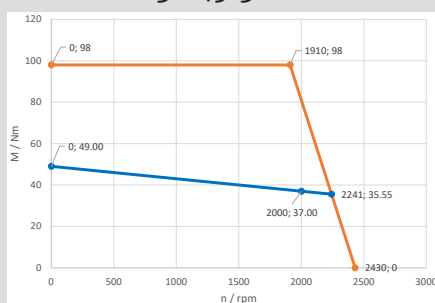

— M max  
— M (S1)

HMD15-049-560-30-\*

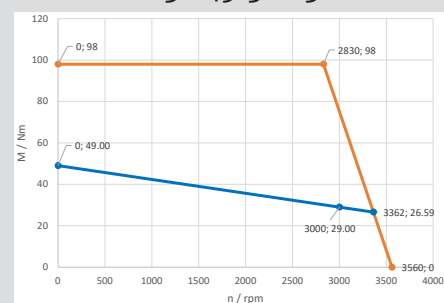

## Dimensions

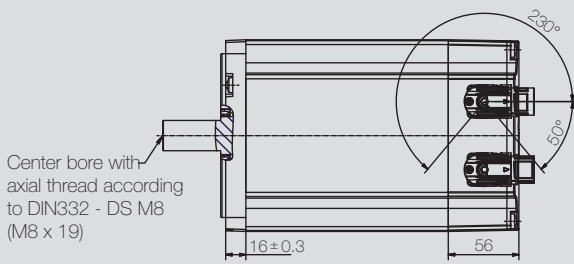
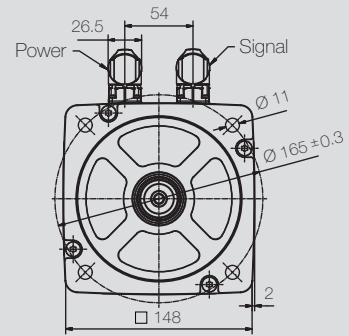
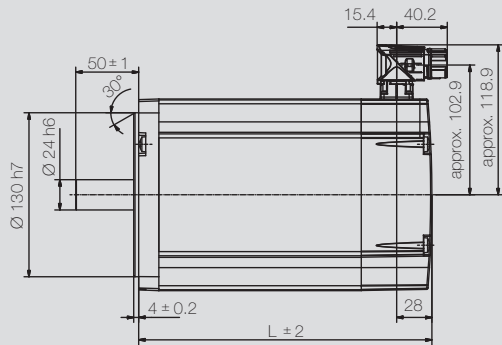

Feather key (option)

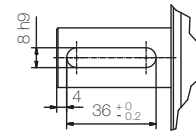
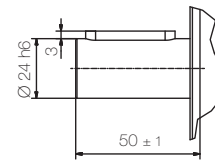

Motor	L [mm]	
	without brake	with brake
HMD15-049	320 mm	384 mm

HMD15

# HMD19-051



## Specifications

HMD19-051

Rated speed [rpm]	$n_n$	2,000	3,000
Number of pole pairs		5	5
Wiring of the motor winding		Y	Y
DC bus voltage [V <sub>DC</sub> ]	$U_{bus}$	560	560
Rated voltage motor [V <sub>rms</sub> ]	$U_{mot}$	284	283
Rated power [W]	$P_n$	7,435	8,000
Rated torque [Nm]	$M_n$	35.5	25.5
Rated current per phase [A <sub>rms</sub> ]	$I_n$	16.6	17.6
<b>Stall torque [Nm]</b>	<b><math>M_0</math></b>	<b>51.0</b>	<b>51.0</b>
Stall current per phase [A <sub>rms</sub> ]	$I_0$	24.5	35.9
Peak torque [Nm]	$M_{max}$	102.0	102.0
Peak current [A <sub>rms</sub> ]	$I_{max}$	49.0	71.8
Maximum speed [rpm]	$n_{max}$	2,600	3,980
Voltage constant at 1,000 rpm [V <sub>rms</sub> ]	$k_e$	141.8	92.7
Torque constant [Nm / A <sub>rms</sub> ]	$k_t$	2.14	1.45
Winding resistance (2 phases) at 20 °C [Ω]	$R_{p-p}$	0.175	0.081
Winding inductance (2 phases) [mH]	$L_{p-p}$	6.88	3.28
Electrical time constant [ms]	$t_{el}$	78.2	40.5
Thermal time constant [min]	$t_{th}$	60	60
Moment of inertia rotor [kg-cm <sup>2</sup> ]	$J$	7.42E+01	7.42E+01
Weight of motor [kg]	$m$	35.0	35.0

All nominal values with resolver.

## Performance

HMD19-051-560-20-\*

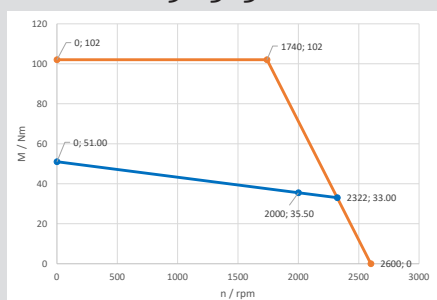

HMD19-051-560-30-\*

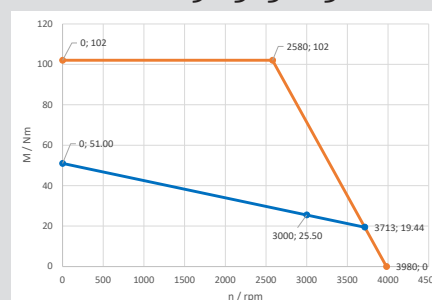

— M max  
— M (S1)

## Dimensions

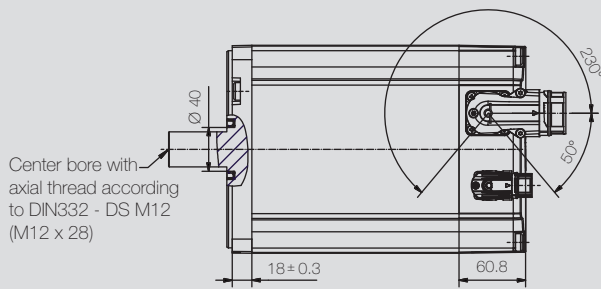
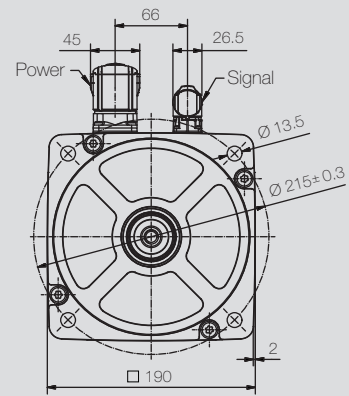
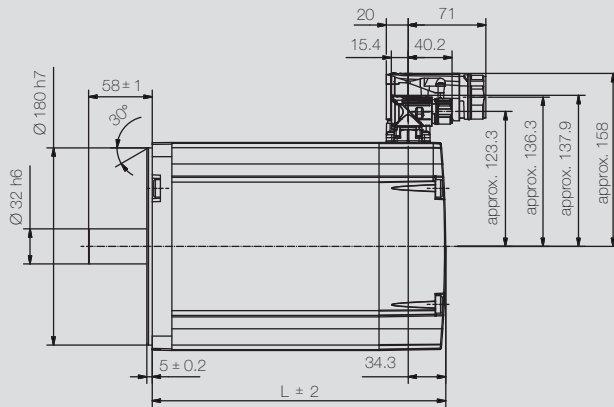

Feather key (option)

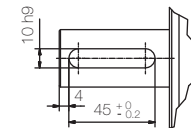
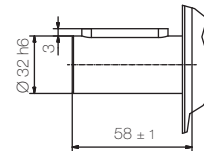

HMD19

Motor	L [mm]	
	without brake	with brake
HMD19-051	283 mm	336 mm

# HMD19-078



## Specifications

HMD19-078

Rated speed [rpm]	$n_n$	2,000	3,000
Number of pole pairs		5	5
Wiring of the motor winding		Y	Y
DC bus voltage [ $V_{DC}$ ]	$U_{bus}$	560	560
Rated voltage motor [ $V_{rms}$ ]	$U_{mot}$	280	273
Rated power [W]	$P_n$	10,780	10,680
Rated torque [Nm]	$M_n$	51.5	34.0
Rated current per phase [ $A_{rms}$ ]	$I_n$	24.4	24.1
<b>Stall torque [Nm]</b>	<b><math>M_0</math></b>	<b>78.0</b>	<b>78.0</b>
Stall current per phase [ $A_{rms}$ ]	$I_0$	38.0	56.6
Peak torque [Nm]	$M_{max}$	156.0	156.0
Peak current [ $A_{rms}$ ]	$I_{max}$	76.0	113.2
Maximum speed [rpm]	$n_{max}$	2,630	4,030
Voltage constant at 1,000 rpm [ $V_{rms}$ ]	$k_e$	140.1	91.4
Torque constant [Nm / $A_{rms}$ ]	$k_t$	2.11	1.41
Winding resistance (2 phases) at 20 °C [ $\Omega$ ]	$R_{p-p}$	0.104	0.046
Winding inductance (2 phases) [mH]	$L_{p-p}$	4.50	2.08
Electrical time constant [ms]	$t_{el}$	42.5	45.2
Thermal time constant [min]	$t_{th}$	70	70
Moment of inertia rotor [kg-cm <sup>2</sup> ]	J	1.10E+02	1.10E+02
Weight of motor [kg]	m	44.0	44.0

All nominal values with resolver.

## Performance

HMD19-078-560-20-\*

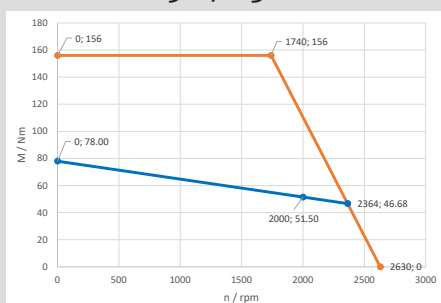

HMD19-078-560-30-\*

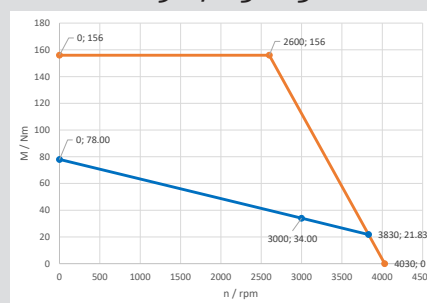

— M max  
— M (S1)

## Dimensions

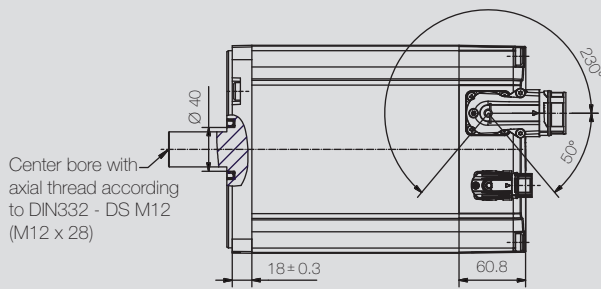
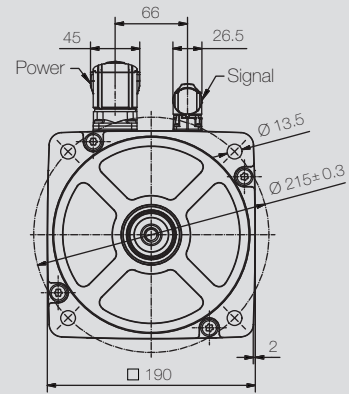
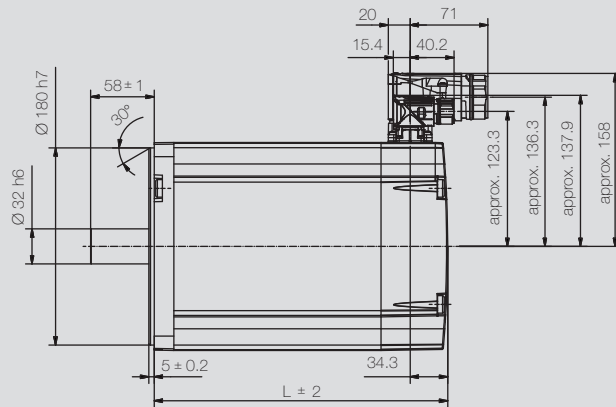

Motor	L [mm]	
	without brake	with brake
HMD19-078	343 mm	406 mm

Feather key (option)

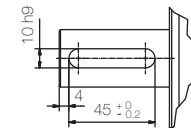
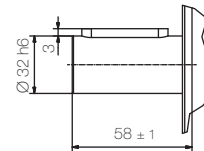

HMD19

# ■ HMD19-105



## Specifications

		HMD19-105
Rated speed [rpm]	$n_n$	2,000
Number of pole pairs		5
Wiring of the motor winding		Y
DC bus voltage [V <sub>DC</sub> ]	$U_{bus}$	560
Rated voltage motor [V <sub>rms</sub> ]	$U_{mot}$	271
Rated power [W]	$P_n$	13,920
Rated torque [Nm]	$M_n$	66.5
Rated current per phase [A <sub>rms</sub> ]	$I_n$	32.5
<b>Stall torque [Nm]</b>	<b><math>M_0</math></b>	<b>105.0</b>
Stall current per phase [A <sub>rms</sub> ]	$I_0$	52.5
Peak torque [Nm]	$M_{max}$	210.0
Peak current [A <sub>rms</sub> ]	$I_{max}$	105.0
Maximum speed [rpm]	$n_{max}$	2,720
Voltage constant at 1,000 rpm [V <sub>rms</sub> ]	$k_e$	135.5
Torque constant [Nm / A <sub>rms</sub> ]	$k_t$	2.05
Winding resistance (2 phases) at 20 °C [Ω]	$R_{p-p}$	0.071
Winding inductance (2 phases) [mH]	$L_{p-p}$	3.20
Electrical time constant [ms]	$t_{el}$	44.8
Thermal time constant [min]	$t_{th}$	80
Moment of inertia rotor [kg-cm <sup>2</sup> ]	$J$	1.45E+02
Weight of motor [kg]	$m$	53.0

All nominal values with resolver.

## Performance

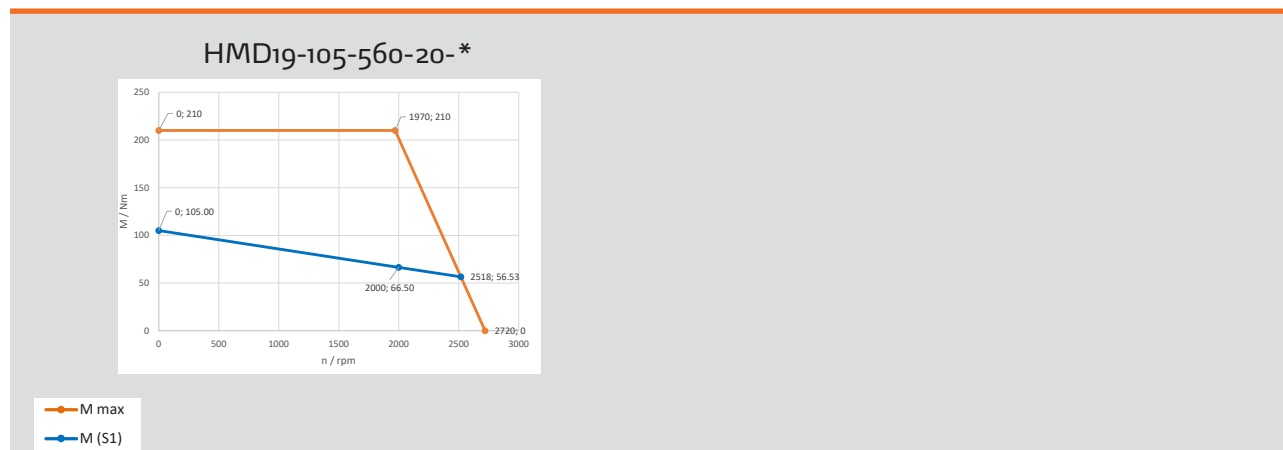

## Dimensions

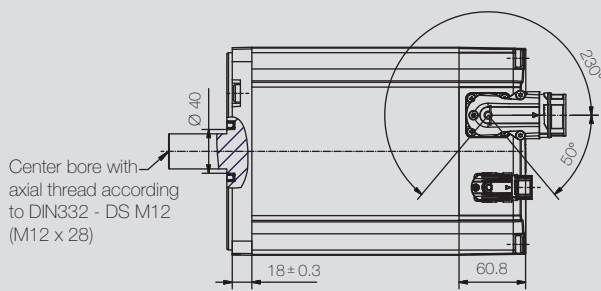
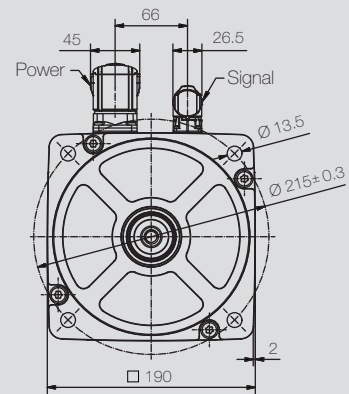
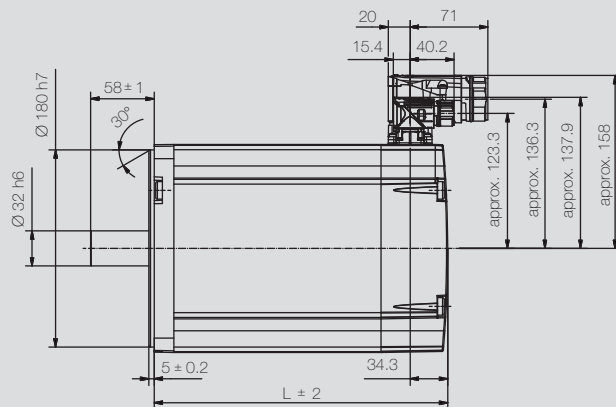

Feather key (option)

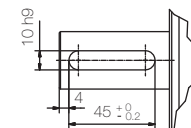
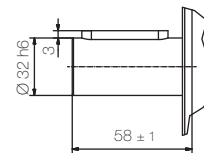

HMD19

Motor	L [mm]	
	without brake	with brake
HMD19-105	403 mm	466 mm

# Configuration Options

## Feedback Options

(Interfaces see page 80 - 89)

As standard, HeiMotion Dynamic motors are supplied with a resolver. As an option, various encoders with different interfaces can be mounted to the series.

Motor model	Resolver*	HES1 (1.0 V pp)	HEM1 (1.0 V pp without battery)	HEM1 (1.0 V pp with battery)	AM 34	HES 3	EClm8	EQI 1131	ECl1319
HMD06-XXX-024-*	X	X	X	X	X	X	X		
HMD06-XXX-048-*	X	X	X	X	X	X	X		
HMD06-XXX-320-*	X	X	X	X	X	X	X	X	
HMD06-XXX-560-*	X	X	X	X	X	X	X	X	
HMD08-XXX-024-*	X	X	X	X	X	X	X		
HMD08-XXX-048-*	X	X	X	X	X	X	X		
HMD08-XXX-320-*	X	X	X	X	X	X	X	X	
HMD08-XXX-560-*	X	X	X	X	X	X	X	X	
HMD10-XXX-048-*	X	X	X	X	X	X	X		
HMD10-XXX-320-*	X	X	X	X	X	X	X	X	
HMD10-XXX-560-*	X	X	X	X	X	X	X	X	
HMD13-XXX-560-*	X	X	X	X	X	X	X	X	
HMD15-XXX-560-*	X	X	X	X	X	X			X
HMD19-XXX-560-*	X	X	X	X	X	X			X

Motor model	ECl 1319	EQI 1331	SEK 37	SEL 37	SKS 36*	SKM 36*	SRS 50	SRM 50
HMD06-XXX-024-*			X	X	X**	X**		
HMD06-XXX-048-*			X	X	X**	X**		
HMD06-XXX-320-*			X	X	X	X		
HMD06-XXX-560-*			X	X	X	X		
HMD08-XXX-024-*			X	X				
HMD08-XXX-048-*			X	X				
HMD08-XXX-320-*			X	X	X	X	X	X
HMD08-XXX-560-*			X	X	X	X	X	X
HMD10-XXX-048-*			X	X				
HMD10-XXX-320-*			X	X	X	X	X	X
HMD10-XXX-560-*			X	X	X	X	X	X
HMD13-XXX-560-*			X	X	X	X	X	X
HMD15-XXX-560-*	X	X	X	X	X	X	X	X
HMD19-XXX-560-*	X	X	X	X	X	X	X	X

Motor model	EES 37*	EEM 37*	EKS 36*	EKM 36*	EDS 35	EDM 35
HMD06-XXX-024-*						
HMD06-XXX-048-*						
HMD06-XXX-320-*	X	X	X	X	X	X
HMD06-XXX-560-*	X	X	X	X	X	X
HMD08-XXX-024-*						
HMD08-XXX-048-*						
HMD08-XXX-320-*	X	X	X	X	X	X
HMD08-XXX-560-*	X	X	X	X	X	X
HMD10-XXX-048-*						
HMD10-XXX-320-*	X	X	X	X	X	X
HMD10-XXX-560-*	X	X	X	X	X	X
HMD13-XXX-560-*	X	X	X	X	X	X
HMD15-XXX-560-*	X	X	X	X	X	X
HMD19-XXX-560-*	X	X	X	X	X	X

## Feedback System Overview

Feedback device type	HCB	HCL
Resolver	X	
HIPERFACE® encoder	X	
HIPERFACE DSL®-encoder	X	
Incremental encoder	X	X
SSI/BISS-C	X	X*
EnDAT® encoder	X	
	p. 104	p. 110

\* HCL 225 C/E incremental only; see overview on page 118.

## Connection Options

The different variants of the connection options can be found on the following pages (p. 78 und p. 79).

## Effective Current Calculation for Connector Design

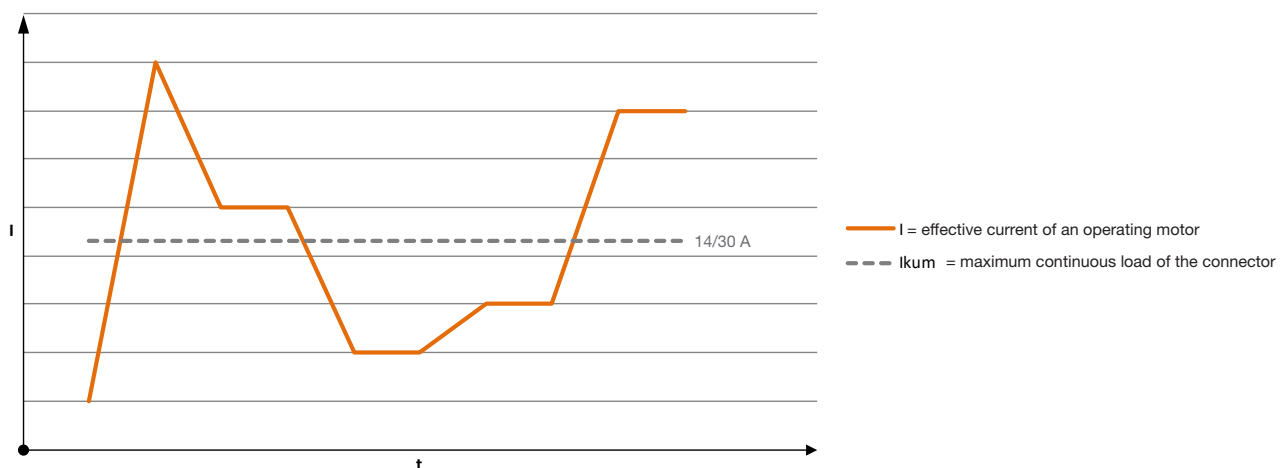

# Connection Technology

## Connection Technology

Motor model	M23	M40+M23	Y-Tec	I-Tec	cable outlet 1, 5 m	cable outlet 5 m	terminal box	short version <sup>2)</sup>	long version <sup>3)</sup>	M23 H-Tec	M40 H-Tec
HMD06-011-024-30	•		•						•		
HMD06-011-048-30	•		•						•		
HMD06-011-048-60	•		•						•		
HMD06-011-320-30	•		•	•	○	○		•			
HMD06-011-320-60	•		•	•	○	○		•			
HMD06-011-560-30	•		•	•	○	○		•			
HMD06-011-560-60	•		•	•	○	○		•			
HMD06-019-048-30	•		•						•		
HMD06-019-320-30	•		•	•	○	○		•			
HMD06-019-320-60	•		•	•	○	○		•			
HMD06-019-560-30	•		•	•	○	○		•			
HMD06-019-560-60	•		•	•	○	○		•			
HMD06-026-048-30	•		•						•		
HMD06-026-048-60	• <sup>1)</sup>								•		
HMD06-026-320-30	•		•	•	○	○		•			
HMD06-026-320-60	•		•	•	○	○		•			
HMD06-026-560-30	•		•	•	○	○		•			
HMD06-026-560-60	•		•	•	○	○		•			
HMD08-024-024-30	○ <sup>1)</sup>						•		•		
HMD08-024-048-30	•						•		•		
HMD08-024-048-55	○ <sup>1)</sup>						•		•		
HMD08-024-320-30	•		•	•	○	○		•			
HMD08-024-320-55	•		•	•	○	○		•			
HMD08-024-560-30	•		•	•	○	○		•			
HMD08-024-560-55	•		•	•	○	○		•			
HMD08-032-024-30	○ <sup>1)</sup>						•		•		
HMD08-032-048-30	•						•		•		
HMD08-032-048-55	○ <sup>1)</sup>						•		•		
HMD08-032-320-30	•		•	•	○	○		•			
HMD08-032-320-55	•		•	•	○	○		•			
HMD08-032-560-30	•		•	•	○	○		•			
HMD08-032-560-55	•		•	•	○	○		•			
HMD08-042-024-30							•		•		
HMD08-042-048-30	○ <sup>1)</sup>						•		•		
HMD08-042-048-55							•		•		
HMD08-042-320-30	•		•	•	○	○		•			
HMD08-042-320-55	•		•	•	○	○		•			
HMD08-042-560-30	•		•	•	○	○		•			
HMD08-042-560-55	•		•	•	○	○		•			
HMD08-057-048-30							•		•		
HMD08-057-320-30	•		•	•	○	○		•			
HMD08-057-320-55	•		•	•	○	○		•			
HMD08-057-560-30	•		•	•	○	○		•			
HMD08-057-560-55	•		•	•	○	○		•			
Rated current (A <sub>rms</sub> )	30.0	72.0	14.0	14.0	upon request	upon request	upon request				

Motor model	M23	M40+M23	Y-Tec	I-Tec	cable outlet 1, 5 m	cable outlet 5 m	terminal box	short version <sup>2)</sup>	long version <sup>3)</sup>	M23 H-Tec	M40 H-Tec
HMD10-039-048-30	○ <sup>1)</sup>						•		•		
HMD10-039-048-50							•		•		
HMD10-039-320-30	•		•	•	○	○		•			
HMD10-039-320-50	•		•	•	○	○		•			
HMD10-039-560-30	•		•	•	○	○		•			
HMD10-039-560-50	•		•	•	○	○		•			
HMD10-057-048-30							•		•		
HMD10-057-048-50							•		•		
HMD10-057-320-30	•		•	•	○	○		•			
HMD10-057-320-50	•		•	•	○	○		•			
HMD10-057-560-30	•		•	•	○	○		•			
HMD10-057-560-50	•		•	•	○	○		•			
HMD10-076-048-30							•		•		
HMD10-076-320-30	•		•	•	○	○		•			
HMD10-076-320-50	•		•	•	○	○		•			
HMD10-076-560-30	•		•	•	○	○		•			
HMD10-076-560-50	•		•	•	○	○		•			
HMD10-105-048-30							•		•		
HMD10-105-320-30	•		•	•	○	○		•			
HMD10-105-320-50	•		•	•	○	○		•			
HMD10-105-560-30	•		•	•	○	○		•			
HMD10-105-560-50	•		•	•	○	○		•			
HMD13-133-560-20	•		•	•	○	○					
HMD13-133-560-36	•		•	•	○	○					
HMD13-190-560-20	•		•	•	○	○					
HMD13-190-560-36	•		•	•	○	○					
HMD13-245-560-20	•		•	•	○	○					
HMD13-245-560-36	•		•	•	○	○					
HMD15-036-560-20	•									•	
HMD15-036-560-30	•									•	
HMD15-043-560-20	•									•	
HMD15-043-560-30	•									•	
HMD15-049-560-20	•									•	
HMD15-049-560-30	•									•	
HMD19-051-560-20	•									•	
HMD19-051-560-30		•									•
HMD19-078-560-20		•									•
HMD19-078-560-30		•									•
HMD19-105-560-20		•									•
Rated current (A <sub>rms</sub> )	30.0	72.0	14.0	14.0	upon request	upon request	upon request			30	70

• Available as standard

○ Only upon request

Other combinations may be possible on request

<sup>1)</sup> Rated and/or standstill current of the motor greater than the rated current of the connection technology. When using this connection method, derating of the motor must be accepted.

<sup>2)</sup> Available for encoder category 1: Resolver, SEK/SEL37, HESx/HEMx, AM 34

<sup>3)</sup> Available for encoder category 2: Remaining encoders

# Standard Resolver

Order Code: R1P

## Specifications

## RE-15

Number of pole pairs	1
Input frequency	10 kHz
Input voltage	7 V <sub>rms</sub>
Current input	max. 50 mA
Transformation ratio	0.5 ± 10 %
Phase shift (nominal)	5° ± 3°
Ohmic resistance (at 25 °C)	
Stator winding	(at 20 °C) 67 ± 10 %
Rotor winding	(at 20 °C) 29 ± 10 %
Impedances	
Z <sub>ro</sub> (no-load impedance rotor)	typ. 95 j 140
Z <sub>so</sub> (no-load impedance stator)	typ. 130 j 250
Z <sub>ss</sub> (short-circuit impedance stator)	typ. 115 j 215
Maximum residual voltage	30 mV
Accuracy	± 10'
Weight	86 g
Protection class	IP20
Insulation class	F
Insulation test housing / winding	500 V <sub>AC</sub> / 50 Hz / 1 s
Moment of inertia rotor	15 g·cm <sup>2</sup>
Order code	XXR1PXXXX



## Environmental

Working environment	IE 32 according to EN 60721-3-3
Operating temperature	- 55 °C to 155 °C
Vibration according to EN 60068-2-6	100 m/s <sup>2</sup> 10 - 150 Hz
Impact strength	400 m/s <sup>2</sup> 6 ms
Maximum operating speed	20,000 rpm

## Dimensions

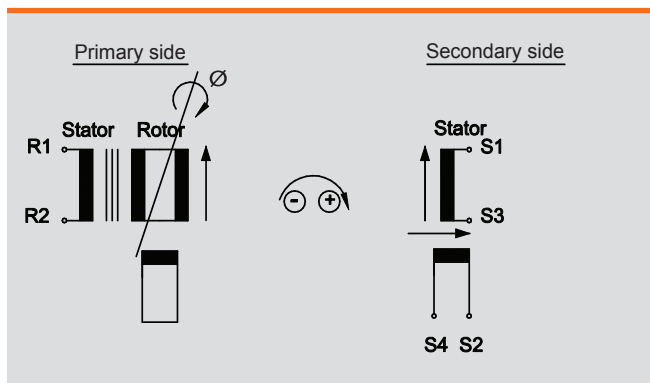

All specified rated motor values determined with resolver.

## Safety Norms

Safety Integrity Level	SIL 2 ( EN 61800-5-2 / EN 62061)
Category	3 (EN ISO 13849-1)
Performance Level	PL d (EN ISO 13849-1)



## ■ Absolute Encoder AM34

### Order Code S1S / B1M

#### Features:

- Integrated, compact dual encoder in the standard HeiMotion modular system
- Singleturn with SSI and sin/cos | Multiturn with BiSS-C<sup>3)</sup> and sin/cos
- Speeds up to 12,000 min<sup>-1</sup>
- Temperature evaluation via BiSS-C possible
- Electronic nameplate possible on request



#### Specifications

##### AM34 (singleturn)

##### AM34 (multiturn)

Supply voltage	5.0 V <sub>DC</sub> +10/-5%	5.0 V <sub>DC</sub> +10/-5%
Power consumption	0.6 W	0.6 W
Max. resolution singleturn	16 bit <sup>1)</sup>	16 bit <sup>1)</sup>
Max. number of absolute revolutions detected	-	12 bit (mechanical)
Data interface	SSI gray (RS422) + SinCos 1V <sub>pp</sub>	BiSS-C (RS422) <sup>2)</sup> + SinCos 1V <sub>pp</sub>
Sin/cos tracks	differential	differential
Number of sin/cos periods per revolution	256	256
Max. angular acceleration	250,000 rad/sec <sup>2</sup>	250,000 rad/sec <sup>2</sup>
Resistance to shocks (DIN EN 60068-2-27)	3,000 m/s <sup>2</sup> (6 ms)	3,000 m/s <sup>2</sup> (6 ms)
Resistance to vibration (DIN EN 60068-2-6)	300 m/s <sup>2</sup> (10...2000 Hz) 100 m/s <sup>2</sup> (10...2000 Hz) min.	300 m/s <sup>2</sup> (10...2000 Hz) 100 m/s <sup>2</sup> (10...2000 Hz) min.
Operating temperature	-40°C / +120°C	-40°C / +120°C
Order code	XXS1SXXXX	XXB1MXXXX

#### Safety Parameters

- Analog output for monitoring functional safety
- SIL2, PL d safety certified
- Encoders for functional safety applications

Encoder

#### Specifications

##### AM34S (singleturn)

##### AM34S (multiturn)

Supply voltage	5 V <sub>DC</sub> +5 % / -5 %	5 V <sub>DC</sub> +5 % / -5 %
Resolution singleturn + multiturn	16 bit singleturn	16 bit singleturn + 12 bit multiturn
Max. angular acceleration	100,000 rad/s <sup>2</sup>	100,000 rad/s <sup>2</sup>
Resistance to shocks (DIN EN 60068-2-27)	1,000 m/s <sup>2</sup> (6 ms)	1,000 m/s <sup>2</sup> (6 ms)
Resistance to vibration (DIN EN 60068-2-6)	300 m/s <sup>2</sup> (10...2,000 Hz) 100 m/s <sup>2</sup> (10...2,000 Hz) min.	300 m/s <sup>2</sup> (10...2,000 Hz) 100 m/s <sup>2</sup> (10...2,000 Hz) min.
Operating temperature	-40°C / +115°C	-40°C / +115°C
Security integrity level (EN IEC 61508, 62061, 61800-5-3)	SIL2	SIL2
Performance level (EN ISO 13849-1)	PL d	PL d
Functional safety architecture	Canal 1: SSI   Canal 2: sin/cos	Canal 1: BiSS-C   Canal 2: sin/cos
Electrical interface	1V <sub>pp</sub> 2.5V <sub>DC</sub> (differential signal - sin+cos) + SSI (RS422)	1V <sub>pp</sub> 2.5V <sub>DC</sub> (differential signal - sin+cos) + BiSS-C (RS422)
Resolution for safety function	512 sin+cos periods	512 sin+cos periods
Order code	XXSASXXXX	XXBAMXXXX

<sup>1)</sup> 20 bit on request

<sup>2)</sup> SSI gray on request

## Inductive Sensing Encoder EnDAT® 2.2

### ECl1118

(Singleturn encoder)

Order Code: E1S



#### Specifications:

- Inductive encoder system without integral bearing
- Purely serial EnDAT® 2.2 interface
- For machines with high demands on dynamics and robustness
- High system accuracy
- Digital data transmission
- Electronic type plate

**EnDat 2.2**

### EQI1131

(Multiturn encoder)

Order Code: E1M



#### Specifications:

- Inductive encoder system without integral bearing
- Multiturn function via gearbox
- Purely serial EnDAT® 2.2 interface
- For machines with high demands on dynamics and robustness
- High system accuracy
- Digital data transmission
- Electronic type plate

**EnDat 2.2**

### ECl1319 / EQI1331

(Single-/ Multiturn encoder)

Order Code: E3S / E3M



#### Specifications:

- Inductive encoder system without integral bearing
- Multiturn function via gearbox
- Purely serial EnDAT® 2.2 interface
- For machines with high demands on dynamics and robustness
- High system accuracy
- Digital data transmission
- Electronic type plate

**EnDat 2.2**

Specifications	ECl1118	EQI1131	ECl1319	EQI1331
Encoder type	inductive	inductive	inductive	inductive
Position values / revolution	262,144 18 bit	524,288 19 bit	524,288 19 bit	524,288 19 bit
Revolutions	-	4,096 12 bit	-	4,096 12 bit
Calculation time $t_{cal}$	$\leq 6 \mu s$	$\leq 5 \mu s$	$\leq 5 \mu s$	$\leq 5 \mu s$
Clock frequency	$\leq 8 \text{ MHz}$	$\leq 16 \text{ MHz}$	$\leq 16 \text{ MHz}$	$\leq 16 \text{ MHz}$
System accuracy	$\pm 120''$	$\pm 120''$	$\pm 65''$	$\pm 65''$
Maximum operating temperature	+ 115 °C - 20 °C	+ 110 °C - 40 °C	+ 115 °C - 40 °C	+ 115 °C - 40 °C
Mechanically permissible speed	15,000 rpm	12,000 rpm	15,000 rpm	12,000 rpm
Voltage supply	3.6 - 14 V <sub>DC</sub>	3.6 - 14 V <sub>DC</sub>	3.6 - 14 V <sub>DC</sub>	3.6 - 14 V <sub>DC</sub>
Max. power consumption	520 - 600 mW	700 - 850 mW	650 - 700 mW	750 - 850 mW
Current consumption (typical) at 5 V	80 mA	115 mA	95 mA	115 mA
Multiturn	-	gearbox	-	gearbox
Vibration 55 Hz to 2,000 Hz Shock 6 ms	$\leq 300 \text{ m/s}^2$ $\leq 1.000 \text{ m/s}^2$		$\leq 400 \text{ m/s}^2$ $\leq 2.000 \text{ m/s}^2$	
Digital interface	EnDAT® 2.2	EnDAT® 2.2	EnDAT® 2.2	EnDAT® 2.2
Order code	XXE1SXXXX	XXE1MXXXX	XXE3SXXXX	XXE3MXXXX

**Encoder**

## Options HIPERFACE®

### Capacitive Sensing Encoder - HIPERFACE®

#### SEK / SEL37

(Single-/ Multiturn encoder)

Order Code: H1S / H1M



#### Specifications:

- 16 sin/cos periods per revolution
- Absolute position with a resolution of 512 steps per revolution
- Measuring of 4,096 revolutions (multiturn)
- Programming of the position value
- HIPERFACE®-interface
- Electronic type label



### Optical Sensing Encoder - HIPERFACE®

#### SKS / SKM36

(Single-/ Multiturn encoder)

Order Code: H2S / H2M



#### Specifications:

- 128 sin/cos periods per revolution
- Absolute position with a revolution of 4,096 steps per revolution
- Measuring of 4,096 revolutions (multiturn)
- Programming of the position value
- HIPERFACE®-interface
- Electronic type label



#### SRS / SRM50

(Single-/ Multiturn encoder)

Order Code: H3S / H3M



#### Specifications:

- 1,024 sin/cos periods per revolution
- Absolute position with a revolution of 32,768 steps per revolution
- Measuring of 4,096 revolutions (multiturn)
- Programming of the position value
- HIPERFACE®-interface
- Electronic type label



Specifications	SEK/SEL37	SKS/SKM36	SRS/SRM50
Number of sin/cos periods per revolution	16	128	1.024
Maximum number of turns	Single SEK 1 Multi SEL 4,096	Single SKS 1 Multi SKM 4,096	Single SRS 1 Multi SRM 4,096
Code type for absolute value	binary	binary	binary
Code sequence <sup>1)</sup>	ascending	ascending	ascending
Measuring step during interpolation of the sin/cos signals (for 12 bit)	20 arc seconds	2.5 arc seconds	0.3 arc seconds
Maximum sin/cos signals interpretation error, integral non-linearity	± 288 arc seconds	± 80 arc seconds	± 45 arc seconds
Non-linearity of a sin/cos period differential non-linearity	± 144 arc seconds <sup>2)</sup>	± 40 arc seconds <sup>2)</sup>	± 7 arc seconds <sup>2)</sup>
Output frequency	-	0 ... 65 kHz	0 ... 200 kHz
Resistance to shocks	100 g / 10 ms	100 g / 6 ms	100 g / 10 ms
Resistance to vibration	50 g / 10...2,000 Hz	50 g / 10...2,000 Hz	50 g / 10...2,000 Hz
Operating voltage range	7...12 V	7...12 V	7...12 V
Recommended supply voltage	8 V	8 V	8 V
Maximum operating current without load	< 50 mA	60 mA	80 mA
Available memory area within EEPROM 2048 <sup>3)</sup>	1,792 bytes	1,792 bytes	1,792 bytes
Interface signals Process data cable = SIN, REFSIN, COS, REFCOS Parameter channel = RS 485	analog, differential digital	analog, differential digital	analog, differential digital
Maximum working temperature		+ 115 °C - 40 °C	
Order code	XXH1SXXXX XXH1MXXXX	XXH2SXXXX XXH2MXXXX	XXH3SXXXX XXH3MXXXX

**Encoder**

## Safety Norms

### SKS/SKM36S

Safety integrity level <sup>4)</sup>	-	SIL2 (EN 61800-5-2 / EN 62061)	-
Category <sup>4)</sup>	-	3 (EN ISO 13849-1)	-
Performance level <sup>4)</sup>	-	PL d (EN ISO 13849-1)	-

1) For rotation of the shaft in clockwise direction when facing in the direction of "A"

2) In the nominal position ± 0.1 mm

3) When using the electronic nameplate in operative connection with numerical controls, consider the patent EP 425 912 B 2; use in operative connection with speed controllers is excluded from this rule.

4) Safety norms are only valid for motors with safely mounted encoders.

## Options HIPERFACE DSL®

### Capacitive Sensing Encoder - HIPERFACE DSL®

#### EES / EEM37

(Single- or Multiturn encoder)

Order code: D1S/D1M



#### Specifications:

- Absolute position with a resolution of 17 Bit
- Measuring of 4,096 revolutions (multiturn)
- Programming of the position value
- HIPERFACE DSL®-interface
- Electronic type label



### Optical Sensing Encoder - HIPERFACE DSL®

#### EKS / EKM36

(Single- or Multiturn encoder)

Order code: D2S/D2M



#### Specifications:

- Absolute position with a resolution of 18 Bit
- Measuring of 4,096 revolutions (multiturn)
- Programming of the position value
- HIPERFACE DSL®-interface
- Electronic type label



#### EDS / EDM35

(Single- or Multiturn encoder)

Order code: D3S/D3M



#### Specifications:

- Absolute position with a resolution of 24 Bit
- Optical motor feedback system
- Measuring of 4,096 revolutions (multiturn)
- Programming of the position value
- HIPERFACE DSL®-interface
- Electronic type label



Specifications	EES/EEM <sub>37</sub>	EKS/EKM <sub>36</sub>	EDS/EDM <sub>35</sub>
Maximum number of turns	Single EES 1 Multi EEM 4.096	Single EKS 1 Multi EKM 4.096	Single EDS 1 Multi EDM 4.096
Code type for absolute value	binary	binary	binary
Code sequence <sup>1)</sup>	ascending	ascending	ascending
System accuracy	± 160 arc seconds	± 120 arc seconds	± 25 arc seconds
Resistance to shocks	100 g / 6 ms	100 g / 6 ms	100 g / 6 ms
Resistance to vibration	50 g / 10...2,000 Hz	50 g / 10...2,000 Hz	50 g / 10...2,000 Hz (according to EN 60068-2-6)
Operating voltage range	7...12 V	7...12 V	7...12 V
Recommended supply voltage	-	8 V	-
Maximum operating current without load	150 mA	150 mA	150 mA
Available memory area within EEPROM 2048 <sup>2)</sup>	8,192 byte	8,192 byte	8,192 byte
Resolution	17 bit	18 bit	24 bit
Maximum working temperature	+ 115 °C - 40 °C	+ 115 °C - 20 °C	+ 115 °C - 40 °C
Order code	××D1S×××× ××D1M××××	××D2S×××× ××D2M××××	××D3S×××× ××D3M××××

**Encoder**

Safety Norms	EES/EEM <sub>37</sub>	EKS/EKM <sub>36-2</sub>
Safety integrity level <sup>3)</sup>	SIL2 (EN 61800-5-2 / EN 62061)	SIL2 (EN 61800-5-2 / EN 62061)
Category <sup>3)</sup>	3 (EN ISO 13849-1)	3 (EN ISO 13849-1)
Performance level <sup>3)</sup>	PL d (EN ISO 13849-1)	PL d (EN ISO 13849-1)

1) For rotation of the shaft in clockwise direction when facing in the direction of "A"

2) When using the electronic nameplate in operative connection with numerical controls, consider the patent EP 425 912 B 2; use in operative connection with speed controllers is excluded from this rule.

3) Safety norms are only valid for motors with safely mounted encoders.

# Options

## SSI / BiSS-C / Incremental Encoder

### Absolute Encoder SSI / BiSS-C

#### HES1-002

Order code: M2S



#### Specifications:

- Singleturn encoder with a resolution of 12 bit
- SSI interface differential and single-ended
- Differential sin/cos signals with 1.0 V<sub>p-p</sub>

#### HEM1-001

Order code: M1M



#### Specifications:

- Multiturn encoder with a total resolution of 32 bit
- Singleturn encoder with a resolution of 12 bit
- SSI interface differential and single-ended
- Differential sin/cos signals with 1.0 V<sub>p-p</sub>
- External battery connector

#### HEM1-002<sup>1)</sup>

Order code: M2M



#### Specifications:

- Multiturn encoder with a total resolution of up to 32 bit
- Singleturn encoder with a resolution of 12 bit
- BiSS interface differential and single-ended
- Differential sin/cos signals with 1.0 V<sub>p-p</sub>
- Battery on board

### Incremental Encoder

#### HES3

Order code: M3I



#### Specifications:

- Commutation and incremental signals ABZ, differential and single-ended
- 2048 PPR<sup>2)</sup>

<sup>1)</sup> Further information for your application upon request.

<sup>2)</sup> Pulses Per Revolution

4 x PPR = Counts Per Revolution (CPR)

## Specifications

(according to DIN 32878)

	HES1-002	HEM1-001	HEM1-002	HES3
Power supply voltage	5.0 V <sub>DC</sub> ± 10%	5.0 V <sub>DC</sub> ± 10%	5.0 V <sub>DC</sub> ± 10%	5.0 V <sub>DC</sub> ± 10%
Maximum output current	50 mA	50 mA	50 mA	50 mA
Resolution singleturn	12 Bit 0,088°	12 Bit 0,088°	12 Bit 0,088°	0,044°
Number of turns	-	20 bit	20 bit	-
Backup battery for multiturn encoder	-	external	on board	-
SSI / BiSS interface	SSI differential & single ended gray coded	SSI differential & single ended binary coded	BiSS differential & single ended binary coded	-
Maximum SSI / BiSS operating frequency	4 MHz	4 MHz	10 MHz	-
Sin/cos signals	differential	differential	differential	-
Number of sin/cos periods per turn	1	1	1	-
Amplitude sin/cos	1.0 V <sub>p-p</sub>	1.0 V <sub>p-p</sub>	1.0 V <sub>p-p</sub>	-
Incremental signals ABZ (PPR)*	-	-	-	differential (2048)
High-level output voltage ABZ	-	-	-	min. 2.8 V
Low-level output voltage ABZ	-	-	-	max. 0.4 V
Commutation signals	-	-	-	differential
Commutation high-level output voltage (UW)	-	-	-	min. 2.8 V
Commutation low-level output voltage (UW)	-	-	-	max. 0.4 V
Maximum working temperature	+ 125 °C - 30 °C			
Permissible relative humidity	15 to 85 % without condensation			
Order code segment	XXM2SXXXX	XXM1MXXXX	XXM2MXXXX	XXM3XXXX

\* Pulses Per Revolution  
4 x PPR = Counts Per Revolution (CPR)

Encoder

## ■ Option Holding Brake

Any HeiMotion Dynamic NG motor can be equipped with a permanent-magnet DC holding brake.  
The standard motors are not suitable for dynamic brakes.

Insulation class:	F (155 °C)
Maximum speed:	10,000 rpm
Voltage supply:	24 V <sub>DC</sub> + 6 % / -10 %

Specifications Brake	HMD06			HMD08			
	-011	-019	-026	-024	-032	-042	-057
Moment of inertia motor <u>with</u> brake * [kg-cm <sup>2</sup> ]	3.47E-01	5.73E-01	8.00E-01	1.04E+00	1.37E+00	1.71E+00	2.36E+00
Static braking torque min. at 20°C [Nm]	2.0	2.0	2.0	4.5	4.5	4.5	4.5
Dynamic braking torque at 20°C [Nm]	1.7	1.7	1.7	3.8	3.8	3.8	3.8
Rated input power at rated voltage and 20°C [W]	11	11	11	12	12	12	12
Working voltage [V <sub>DC</sub> ]	24	24	24	24	24	24	24
Input current brake at 20°C [A]	0.46	0.46	0.46	0.50	0.50	0.50	0.50
Energy rating [kJ]	410	410	410	580	580	580	580
Separating time brake [ms]	≤40	≤40	≤40	≤38	≤38	≤38	≤38
Brake delay [ms]	≤3	≤3	≤3	≤3	≤3	≤3	≤3
Application delay time [ms]	≤15	≤15	≤15	≤20	≤20	≤20	≤20
Weight of motor <u>with</u> brake * [kg]	1.55	1.95	2.35	3.15	3.55	3.95	5.05
Slipping time ** [s]	0.5	0.5	0.5	0.5	0.5	0.5	0.5
Idle time ** [s]	0.5	0.5	0.5	0.5	0.5	0.5	0.5
Speed ** [min <sup>-1</sup> ]	100	100	100	100	100	100	100
Cycle quantity ** [-]	5	5	5	5	5	5	5

Specifications brake	HMD10				HMD13		
	-039	-057	-076	-105	-133	-190	-245
Moment of inertia motor <u>with</u> brake * [kg-cm <sup>2</sup> ]	2.62E+00	3.43E+00	4.25E+00	5.89E+00	1.01E+01	1.39E+01	2.32E+01
Static braking torque min. at 20°C [Nm]	9.0	9.0	9.0	9.0	20.0	20.0	36.0
Dynamic braking torque min. at 20°C [Nm]	7.5	7.5	7.5	7.5	15.0	15.0	30.0
Rated input power at rated voltage and 20°C [W]	18	18	18	18	28	28	26
Working voltage [V <sub>DC</sub> ]	24	24	24	24	24	24	24
Input current brake at 20°C [A]	0.75	0.75	0.75	0.75	1.17	1.17	1.08
Energy rating [kJ]	890	890	890	890	1,290	1,290	2,900
Separating time brake [ms]	≤70	≤70	≤70	≤70	≤90	≤90	≤135
Brake delay [ms]	≤3	≤3	≤3	≤3	≤3	≤3	≤7
Application delay time [ms]	≤30	≤30	≤30	≤30	≤35	≤35	≤35
Weight of motor <u>with</u> brake * [kg]	5.50	6.00	6.50	7.50	9.50	12.10	16.50
Slipping time ** [s]	0.5	0.5	0.5	0.5	0.5	0.5	0.5
Idle time ** [s]	0.5	0.5	0.5	0.5	0.5	0.5	0.5
Speed ** [min <sup>-1</sup> ]	100	100	100	100	75	75	50
Cycle quantity ** [-]	5	5	5	5	5	5	3

Specifications brake	HMD15			HMD19		
	-036	-043	-049	-051	-078	-105
Moment of inertia motor <u>with</u> brake * [kg-cm <sup>2</sup> ]	4.69E+01	5.63E+01	7.01E+01	8.23E+01	1.60E+02	1.95E+02
Static braking torque min. at 20°C [Nm]	45.0	45.0	65.0	65.0	115.0	115.0
Dynamic braking torque at 20°C [Nm]	24.0	24.0	35.0	35.0	70.0	70.0
Rated input power at rated voltage and 20°C [W]	21	21	28	40	50	50
Working voltage [V <sub>DC</sub> ]	24	24	24	24	24	24
Input current brake at 20°C [A]	0.853	0.853	1.16	1.67	2.08	2.08
Energy rating [kJ]	2,600	2,600	4,500	4,500	13,000	13,000
Separating time brake [ms]	≤200	≤200	≤200	≤200	≤190	190
Brake delay [ms]	6	6	10	10	12	12
Application delay time [ms]	≤50	≤50	≤50	≤50	65	65
Weight of motor <u>with</u> brake * [kg]	22.0	26.0	31.5	40.0	51.5	61.5
Slipping time ** [s]	0.5	0.5	0.5	0.5	0.5	0.5
Idle time ** [s]	0.5	0.5	0.5	0.5	0.5	0.5
Speed ** [min <sup>-1</sup> ]	50	50	25	25	15	15
Cycle quantity ** [-]	3	3	3	3	3	3

Brake

\* Incl. all attachment parts

\*\* In order to ensure the optimum function of the brake at all times, it is recommended that the respective maintenance cycle (refreshment) be carried out when the brake is first put into operation and at four-week intervals.

# Option Connector Y-Tec

Oder Code: Y17



Power		Signal Resolver	Signal HIPERFACE®	Signal SSI/BiSS	Signal EnDAT® 2.2		
Pin	Function	Pin	Function	Pin	Function		
A	U	1	cos +	1	cos +	1	-
B	V	2	cos - / refcos	2	cos - / refcos	2	-
C	W	3	sin +	3	sin +	3	-
Ground.	PE	4	sin- / refsin	4	sin- / refsin	4	-
1	Temp + <sup>2)</sup>	5	R1 (ref +)	5	Data +	5	U <sub>p</sub>
2	Temp - <sup>2)</sup>	6	R2 (ref -)	6	Data -	6	GND / 0 V
3	Brake + <sup>1)</sup>	7	-	7	Us	7	Data +
4	Brake - <sup>1)</sup>	8	-	8	GND	8	Data -
5	-	9	Temp +	9	Temp +	9	CLK +
		10	Temp -	10	Temp -	10	CLK -
		11	-	11	-	11	Temp + <sup>3)</sup>
		12	-	12	-	12	Temp - <sup>4)</sup>

1) If applicable  
2) Only with, HES3 and HEM1-001

3) Battery + at HEM1-001  
4) Battery - at HEM1-001

## Motor Connector

View mating face

9-pole 9 x Ø 1 mm (3+PE+5)	12-pole 12 x Ø 1 mm	12-pole 12 x Ø 1 mm	12-pole 12 x Ø 1 mm	12-pole 12 x Ø 1 mm

## Mating Connector

View mating face

Intercontec type designation ESTA 202 NN00 34 0500 000 (Cable clamping range 10.5 - 12 mm)	Intercontec type designation ESTA 002 NN00 33 0001 000 (Cable clamping range 8.5 - 10.5 mm)	Intercontec type designation ESTA 002 NN00 33 0001 000 (Cable clamping range 8.5 - 10.5 mm)	Intercontec type designation ESTA 002 NN00 33 0001 000 (Cable clamping range 8.5 - 10.5 mm)	Intercontec type designation ESTA 002 NN00 33 0001 000 (Cable clamping range 8.5 - 10.5 mm)

## Signal Incremental

Pin	Function
1	Z
2	$\bar{Z}$
3	A
4	$\bar{A}$
5	B
6	$\bar{B}$
7	$\bar{U}$ (R)
8	U (R)
9	$\bar{V}$ (S)
10	V (S)
11	$\bar{W}$ (T)
12	W (T)
A	V <sub>CC</sub> / 5 V
B	GND
C	-

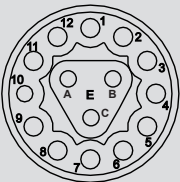

15-pole  
15 x Ø 1 mm

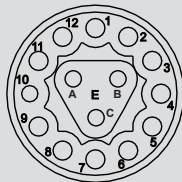

15-pole  
15 x Ø 1 mm

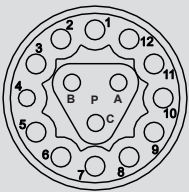

Intercontec type designation  
ESTA 205 NN00 33 0001 000  
(Cable clamping range  
8.5 - 10.5 mm)

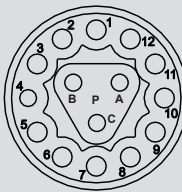

Intercontec type designation  
ESTA 205 NN00 33 0001 000  
(Cable clamping range  
8.5 - 10.5 mm)



Mating connector with metal gland as shown or with plastic gland.

## Motor Connector Angled receptacle Y-Tec, rotatable

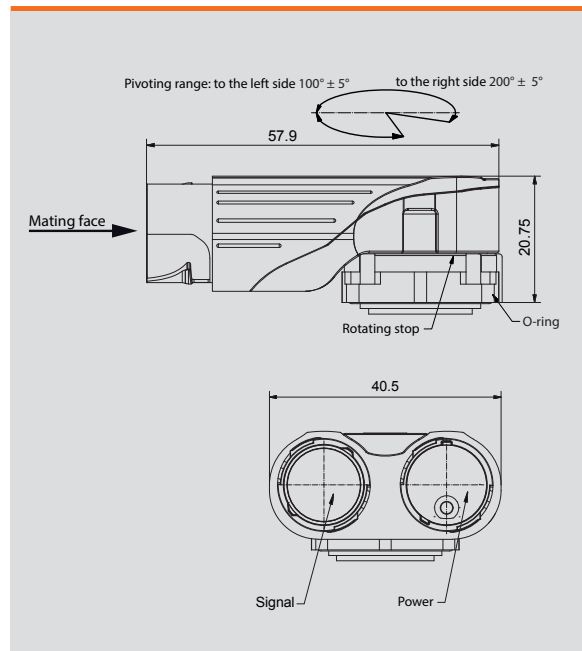

## Mating connector

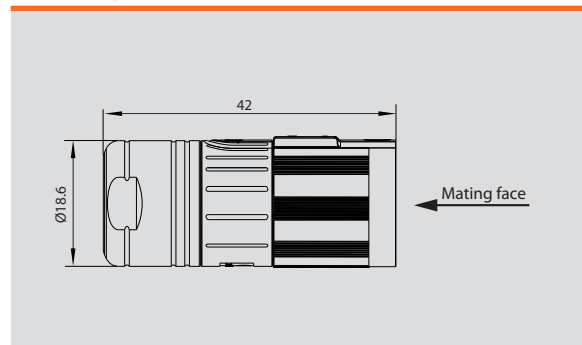

Connector

# Option Connector M23

Oder Code: W23



Power	Signal Resolver	Signal HIPERFACE®	Signal SSI/BiSS	Signal EnDAT® 2.2
-------	-----------------	-------------------	-----------------	-------------------

Pin	Function	Pin	Function	Pin	Function	Pin	Function	Pin	Function
A	Brake + <sup>1)</sup>	1	cos +	1	cos +	1	cos +	1	-
B	Brake - <sup>1)</sup>	2	cos - / refcos	2	cos - / refcos	2	cos - / refcos	2	-
C	Temp +	3	sin +	3	sin +	3	sin +	3	-
D	Temp -	4	sin - / refsln	4	sin - / refsln	4	sin - / refsln	4	-
1	U	5	-	5	-	5	V <sub>CC</sub> / 5 V	5	U <sub>p</sub>
4	V	6	R1 (ref +)	6	-	6	GND	6	GND/OV
3	W	7	R2 (ref -)	7	GND	7	Data +	7	Data +
Ground.	PE	8	-	8	-	8	Data -	8	Data -
		9	-	9	US	9	CLK +	9	Clock +
		10	-	10	Data +	10	CLK -	10	Clock -
		11	Temp +	11	Data -	11	Temp +	11	Temp +
		12	Temp -	12	-	12	Temp -	12	Temp -
				13	-	13	- <sup>2)</sup>	13	-
				14	Temp +	14	- <sup>3)</sup>	14	-
				15	Temp -	15	-	15	-
				16	-	16	-	16	-
				17	-	17	-	17	-

1) If applicable  
 2) Battery + at HEM1-001  
 3) Battery - at HEM1-001

## Motor Connector

View mating face

<p>8-pole                  4 x Ø 2 mm (3+PE)                  + 4 x Ø 1 mm</p>	<p>12-pole                  12 x Ø 1 mm, 0° coded</p>	<p>17-pole                  17 x Ø 1 mm, 0° coded</p>	<p>17-pole                  17 x Ø 1 mm, 0° coded</p>	<p>17-pole                  17 x Ø 1 mm, 0° coded</p>
--	---	---	---	---

## Mating connector

View mating face

<p>Intercontec type designation                  BSTA 078 NN00 42 0100 000                  (Cable clamping range                  9.5-14.5 mm)</p>	<p>Intercontec type designation                  ASTA 013 NN00 41 0100 000                  (Cable clamping range                  6-10 mm)</p>	<p>Intercontec type designation                  ASTA 014 NN00 41 0100 000                  (Cable clamping range                  6-10 mm)</p>	<p>Intercontec type designation                  ASTA 014 NN00 41 0100 000                  (Cable clamping range                  6-10 mm)</p>	<p>Intercontec type designation                  ASTA 014 NN00 41 0100 000                  (Cable clamping range                  6-10 mm)</p>
---	---	---	---	---

## Signal Incremental

Pin	Function
1	Z
2	$\bar{Z}$
3	A
4	$\bar{A}$
5	B
6	$\bar{B}$
7	U (R)
8	$\bar{U}$ ( $\bar{R}$ )
9	V (S)
10	$\bar{V}$ ( $\bar{S}$ )
11	W (T)
12	$\bar{W}$ ( $\bar{T}$ )
13	V <sub>CC</sub> / 5 V
14	GND
15	Temp +
16	Temp -
17	-

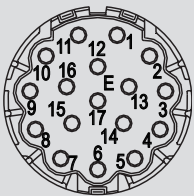

17-pole  
17 x Ø 1 mm, 0° coded

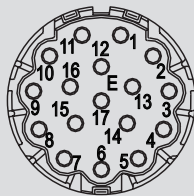

17-pole  
17 x Ø 1 mm, 0° coded

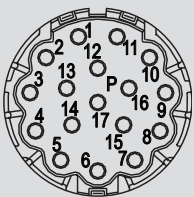

Intertecc type designation  
ASTA 014 NN00 41 0100 000  
(Cable clamping range  
6-10 mm)

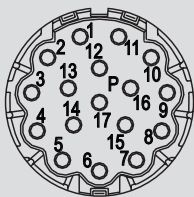

Intertecc type designation  
ASTA 014 NN00 41 0100 000  
(Cable clamping range  
6-10 mm)



## Motor Connector

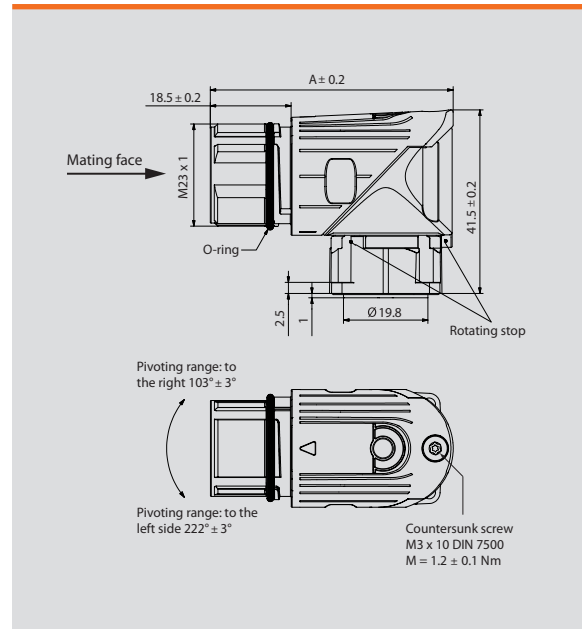

## Mating Connector

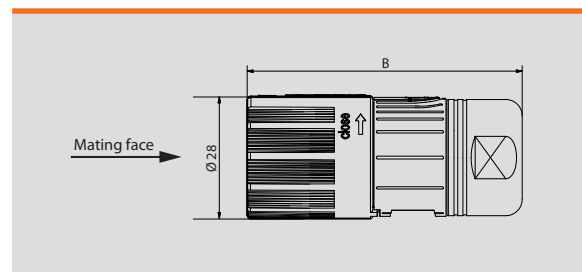

Connector type	A	B
Signal	55.6	59
Power	55.3	78

Connector

# Option Connector M40 + M23



Power		Signal Resolver	Signal HIPERFACE®	Signal SSI/BiSS	Signal EnDAT® 2.2				
Pin	Function	Pin	Function	Pin	Function	Pin	Function	Pin	Function
+	Brake + *	1	cos +	1	cos +	1	cos +	1	-
-	Brake - *	2	cos - / refcos	2	cos - / refcos	2	cos - / refcos	2	-
1	Temp +	3	sin +	3	sin +	3	sin +	3	-
2	Temp -	4	sin - / refsin	4	sin - / refsin	4	sin - / refsin	4	-
U	U	5	-	5	-	5	V <sub>CC</sub> / 5 V	5	U <sub>p</sub>
V	V	6	R1 (ref +)	6	-	6	GND	6	GND / 0 V
W	W	7	R2 (ref -)	7	GND	7	Data +	7	Data +
Ground.	PE	8	-	8	-	8	Data -	8	Data -
* If applicable		9	-	9	US	9	CLK +	9	CLK +
		10	-	10	Data +	10	CLK -	10	CLK -
		11	Temp +	11	Data -	11	Temp +	11	Temp +
		12	Temp -	12	-	12	Temp -	12	Temp -
				13	-	13	-	13	-
				14	Temp +	14	-	14	-
				15	Temp -	15	-	15	-
				16	-	16	-	16	-
				17	-	17	-	17	-

## Motor Connector

View mating face

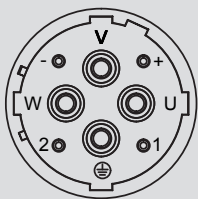

8-pole  
4 x Ø 3.6 mm (3+PE)  
+ 4 x Ø 2 mm

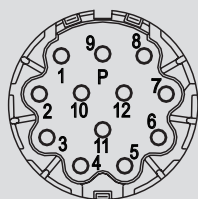

12-pole  
12 x Ø 1 mm, 0° coded

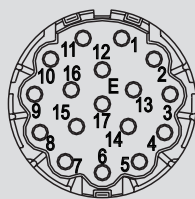

17-pole  
17 x Ø 1 mm, 0° coded

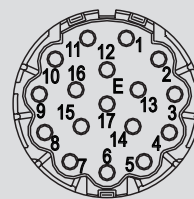

17-pole  
17 x Ø 1 mm, 0° coded

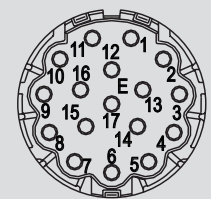

17-pole  
17 x Ø 1 mm, 0° coded

## Mating Connector

View mating face

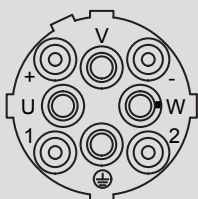

Intercontec type designation  
CSTA 264 NN00 4400 20000  
(Cable clamping range  
9-16 mm)

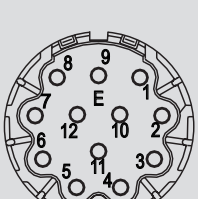

Intercontec type designation  
ASTA 013 NN00 41 0100 000  
(Cable clamping range  
6-10 mm)

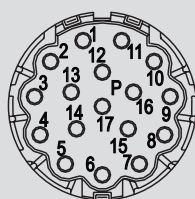

Intercontec type designation  
ASTA 014 NN00 41 0100 000  
(Cable clamping range  
6-10 mm)

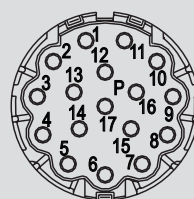

Intercontec type designation  
ASTA 014 NN00 41 0100 000  
(Cable clamping range  
6-10 mm)

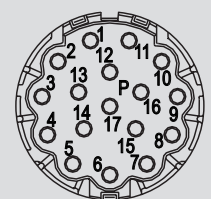

Intercontec type designation  
ASTA 014 NN00 41 0100 000  
(Cable clamping range  
6-10 mm)

## Signal Incremental

Pin	Function
1	Z
2	$\bar{Z}$
3	A
4	$\bar{A}$
5	B
6	$\bar{B}$
7	U (R)
8	$\bar{U}$ ( $\bar{R}$ )
9	V (S)
10	$\bar{V}$ ( $\bar{S}$ )
11	W (T)
12	$\bar{W}$ ( $\bar{T}$ )
13	V <sub>cc</sub> / 5 V
14	GND
15	Temp +
16	Temp -
17	-

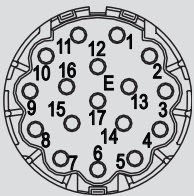

17-pole  
17 x Ø 1 mm, 0° coded

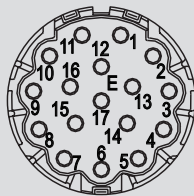

17-pole  
17 x Ø 1 mm, 0° coded

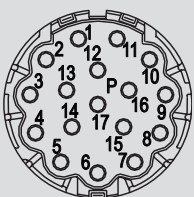

Intercontec type designation  
ASTA 014 NN00 41 0100 000  
(Cable clamping range  
6-10 mm)

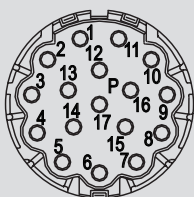

Intercontec type designation  
ASTA 014 NN00 41 0100 000  
(Cable clamping range  
6-10 mm)



## Power Connector M40

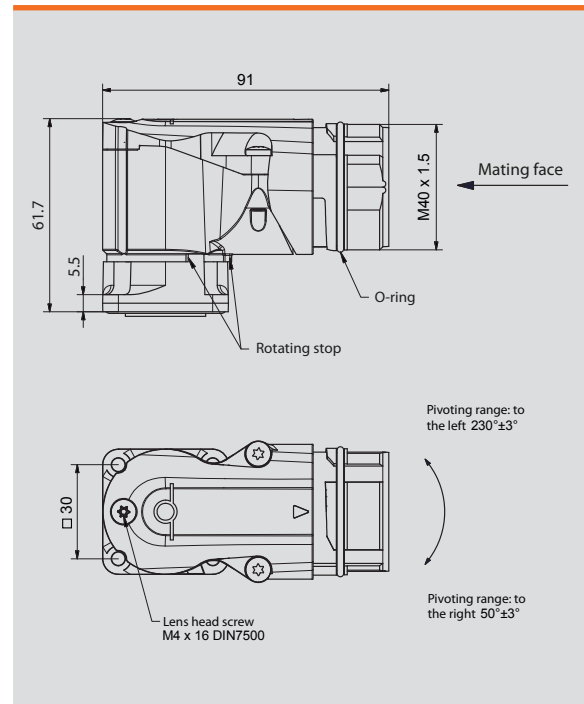

## Mating Connector

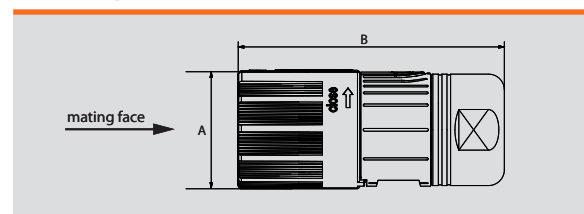

Connector type	A	B
Signal	Ø 28	59
Power	Ø 46	99

Connector

# Terminal Box

Order Code: KBo/KB2/KAo/KA2



## Signal DSL

## Signal Resolver

## Signal HIPERFACE®

## Signal SSI/BISS

## Signal EnDAT® 2.2

Pin	Function	Pin	Function	Pin	Function	Pin	Function	Pin	Function
1	-	1	cos +	1	cos +	1	cos +	1	-
2	-	2	cos -	2	cos -	2	cos - / refcos	2	-
3	-	3	sin +	3	sin +	3	sin +	3	-
4	-	4	sin -	4	sin -	4	sin - / refs sin	4	-
5	-	5	Ref+	5	-	5	Battery+ <sup>1)</sup>	5	-
6	-	6	-	6	-	6	-	6	-
7	-	7	Ref-	7	GND	7	Battery- <sup>1)</sup>	7	-
8	US (DSL +)	8	-	8	-	8	Data +	8	Data +
9	GND (DSL -)	9	-	9	US	9	Data -	9	Data -
10	-	10	-	10	Data +	10	CLK+	10	CLK +
11	-	11	-	11	Data -	11	CLK-	11	CLK -
12	Brake +	12	Brake +	12	Brake+	12	Brake +	12	Brake +
13	-	13	-	13	-	13	-	13	-
14	-	14	-	14	-	14	-	14	-
15	-	15	-	15	-	15	Vcc/5V	15	Up
16	-	16	-	16	-	16	GND	16	GND
17	-	17	Temp +	17	Temp +	17	Temp +	17	Temp +
18	-	18	Temp -	18	Temp -	18	Temp -	18	Temp -
19	Brake -	19	Brake -	19	Brake -	19	Brake -	19	Brake -

<sup>1)</sup> Battery +/- for HEM1-001

## Power

According to power connection terminal board (see picture below). Possible cable to be used: Heluca-ble TOPSERV 109 PUR 4 G 10 Art. No.: 75947 VDE 0298-4 must be considered when selecting cables.

## Ring Tongue:

6,73 x 22,05  
E-CU-galv. tinned  
6,64 – 10,5 mm<sup>2</sup>

## Bolt:

M6 x 25 brass according to DIN 933 / ISO 4017

## Power connection terminal board

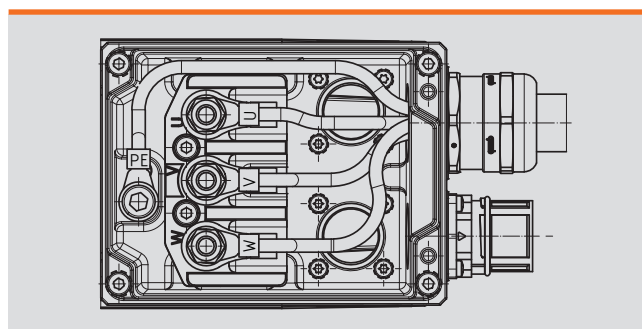

Oder code	Explanation
KA0	Connections in A-side direction without cable gland
KA2	Connections in A-side direction, with cable gland
KB0	Connections in B-side direction, without cable gland
KB2	Connections in B-side direction with cable gland

For UL approval, an S1 characteristic curve deviating by approx. 15 % applies. The specifications on the nameplates correspond to the UL values.

## Signal Incremental

Pin	Function
1	Z
2	Z̄
3	A
4	Ā
5	B
6	-
7	B̄
8	U (R)
9	-
10	V (S)
11	-
12	Brake +
13	W (T)
14	-
15	Vcc/5c
16	GND -
17	Temp +
18	Temp -
19	Brake -

### Motor Connector

View mating face

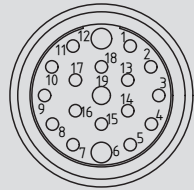

19-pole P  
(16 x Ø 1 mm +  
3 x Ø 1.5 mm)

### Mating Connector

View mating face

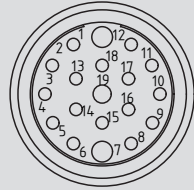

Intercontec type designation  
ASTA 558 NN 00 41 0100 000  
(Cable clamping range  
6-10 mm)

### Cable Gland

Clamping range 13-18mm

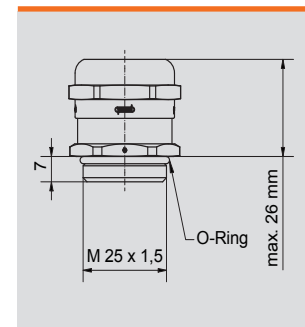

Cable gland - included for order codes KA2 and KB2.

### Mating Connector

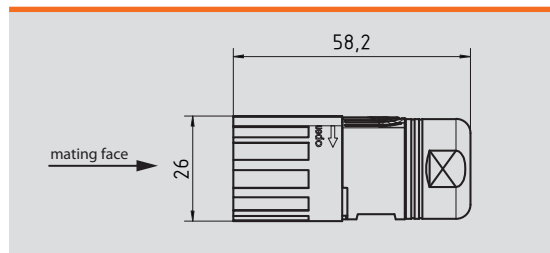

### Front View

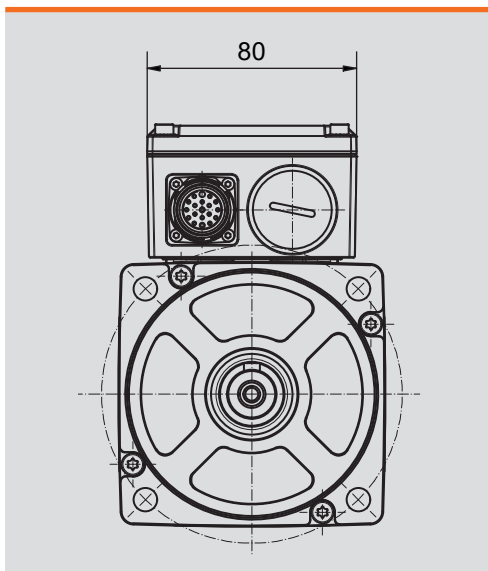

### Mounting Direction

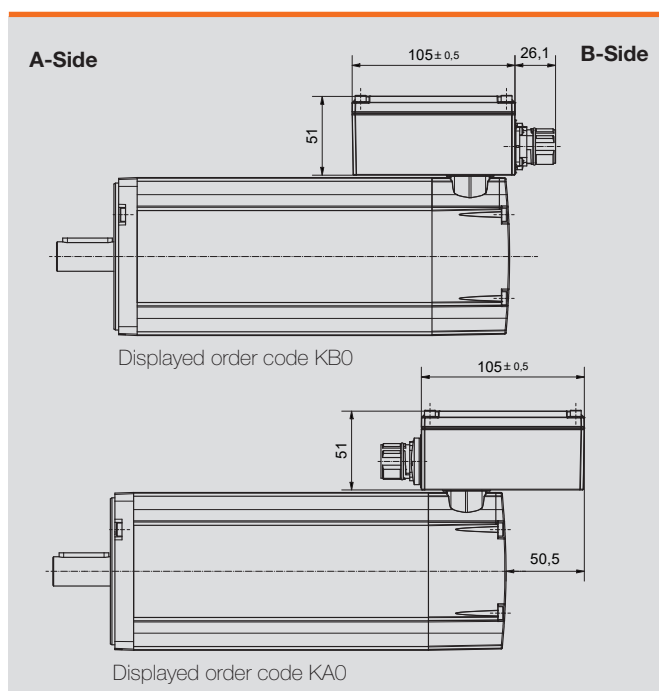

Connector

# Option Connectors for One Cable Solution

## I-Tec Connector

Order code: I17



### Power / Signal

Pin	Function
A	U
B	V
C	W
Grounding	PE
1	U <sub>s</sub> (DSL +)
2	GND (DSL -)
3	Brake + *
4	Brake - *
5	-

### Motor Connector

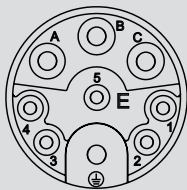

9-pole  
9 x Ø 1 mm (3+PE+5)

### Mating Connector

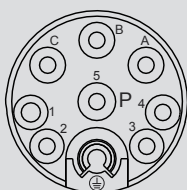

Intercontec type designation  
ESTA 202 NN00 34 0500 000  
(Cable clamping range 10.5 - 12 mm)

\* If available

### Motor Connector

Pivoting range:

to the left  $100^\circ \pm 5^\circ$  to the right  $200^\circ \pm 5^\circ$

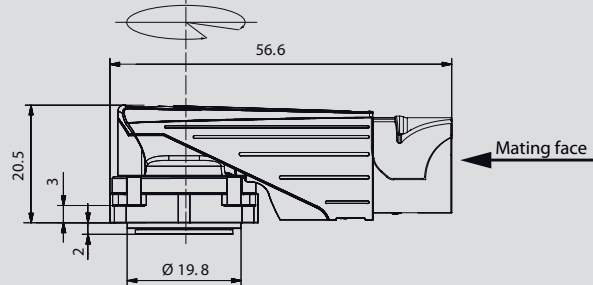

Assembly window

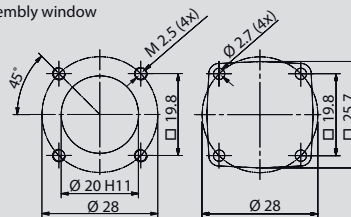

### Mating Connector

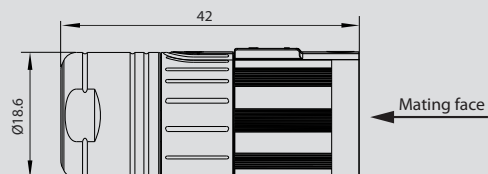

# M23 Connector

for motor sizes 60 to 130



## Power / Signal

Pin	Function
A	Brake + *
B	Brake - *
C	U <sub>s</sub> (DSL+)
D	GND (DSL-)
1	U
4	V
3	W
Grounding	PE

## Motor Connector

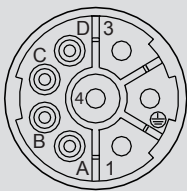

8-pole  
4 x Ø 2mm (3+PE) + 4 x Ø 1mm

## Motor Connector

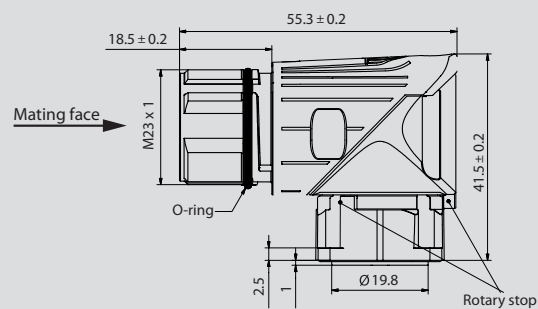

Pivoting range: to the right 103° ± 3°

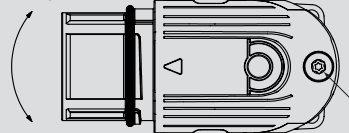

Pivoting range: to the left side 222° ± 3°

Countersunk screw  
M3 x 10 DIN 7500  
M = 1.2 ± 0.1 Nm

## Mating Connector

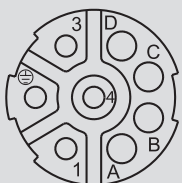

Intercontec type designation  
BSTA 078 NN00 42 0100 000  
(Cable clamping range 9.5 - 14.5 mm)

## Mating Connector

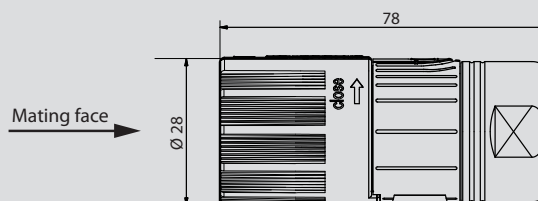

\* If available

# Option Connectors for One Cable Solution

## M23 H-Tec (Hybrid) Connector

for motor size 150 and 190

Order code: I23



### Power / Signal

Pin	Function
A	U
B	V
C	W
D	-
Grounding	PE
7	Brake + *
8	Brake - *
H	U <sub>s</sub> (DSL +)
L	GND (DSL -)

### Motor Connector

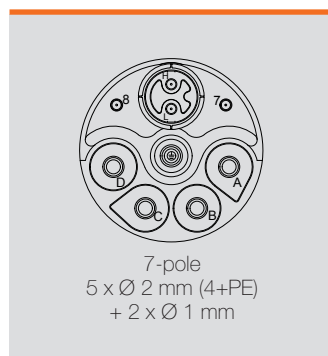

### Mating Connector

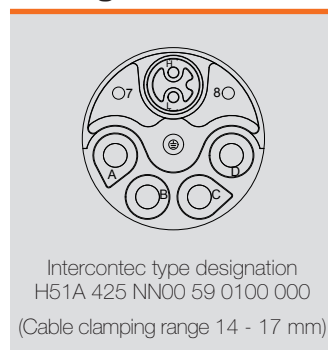

\* If available

### Motor Connector

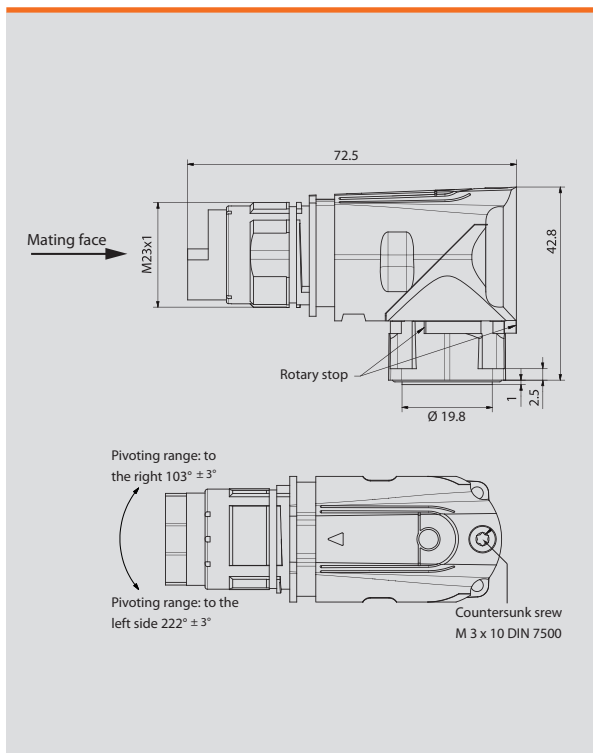

### Mating Connector

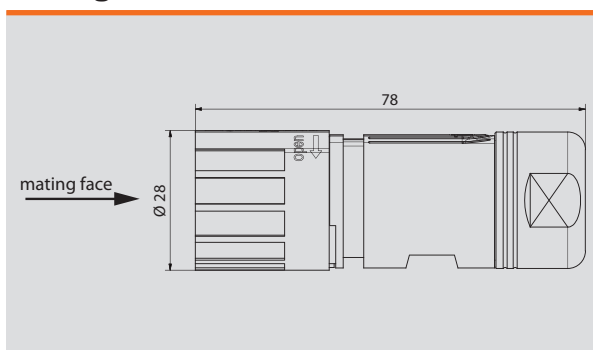

# M40 H-Tec (Hybrid) Connector

for motor size 190  
Order code: I40



## Power / Signal

Pin	Function
U	U
V	V
W	W
Grounding	PE
+	Brake + *
-	Brake - *
1	-
2	-
H	U <sub>s</sub> (DSL +)
L	GND (DSL -)

## Motor Connector



## Motor Connector

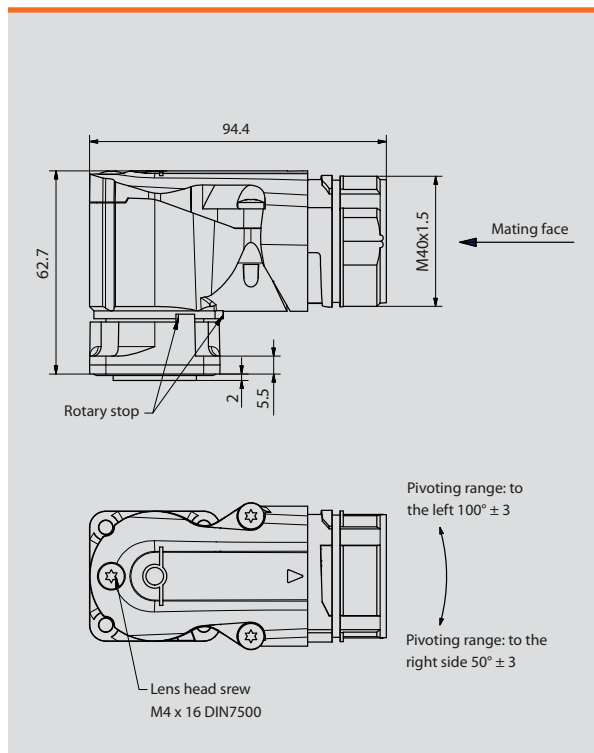

## Mating Connector

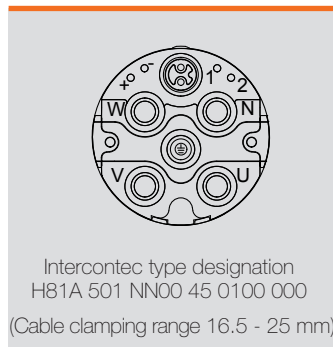

## Mating Connector

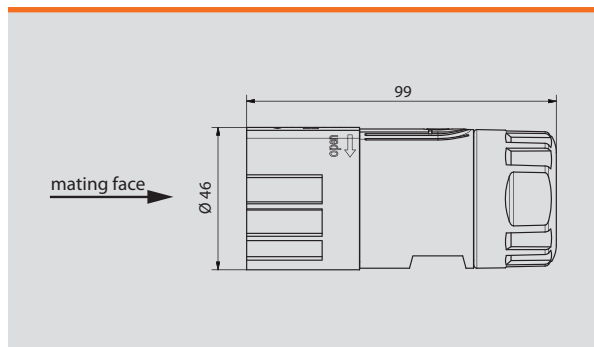

\* If available

## ■ HCB Servo Drive

### General Information

The compact single-axis servo drives of the HCB-series are true all-rounders in drive technology. They combine maximum power density with extensive motion control functions. The HCB-series consists of two sizes, which are divided into two power stages for the 1-phase units and three power stages for the 3-phase units.



All proven fieldbus interfaces are “on board” – from CANopen® to EtherCAT® to PROFINET®, which promise problem-free communication. Its versatility is further underlined by the numerous encoder interfaces, also for single-cable solutions. Complex positioning tasks through linked position sets can be interconnected. The position-synchronous or speed-synchronous motion of various drives with variable gear ratios can be quickly parameterised via the software assistant. Rotary table applications, position triggers, rotor position triggers or switching cams – a wide range of dynamic application tasks can be handled via the integrated software functions.

In combination with the HeiMotion servo motors with encoder variant matched to your application and a gearbox from the HMPG series mounted in the gearbox direct attachment, you get a customized drive axis from a single source at an unbeatable price-performance ratio.

### ■ Connections / Inputs and Outputs

Connection	Function
X1	I/O communication
X2A	Resolver connection
X2B	Multi-encoder connection
X3	STO interface (STOA, STOB), limit switch (DIN6, DIN7) Dig. output (DOUT0)
X4	CANopen®
X6	Motor connection
X6A	Motor brake / HIPERFACE DSL® (HCB 3-phase)
X9	Voltage supply
X9A	Brake resistor (HCB 3-phase)
X9B	24V supply (HCB 3-phase)
X18	Ethernet interface
X19	USB interfae
X21	Realtime Ethernet interface

## ■ General Properties

### Ambient Conditions

Ambient temperature in operation:	0 °C to +40 °C +40 °C to +50 °C with power reduction 2.5 % / K
Storage temperature:	-25 °C to +70 °C
Operating and storage humidity:	Relative humidity 90 % (without condensation)
Protection class:	IP20
Installation altitude:	Mounting height max. 2000 m above sea level, above 1000 m above sea level with power reduction 1 % per 100 m
Degree of pollution:	2
Type of installation	Installation in switch cabinet with at least protection class IP54

### Functions\*

- Safety function "Safe Torque Off" (STO)
- Realization of functionality SS1 possible
- Switching cams
- Direct control of the holding brake in the motor
- Automatic determination of motor parameters
- Position set-dependent synchronization possible
- Path program / linking
- Integrated position control
- Parameterizable belt locks

\* Some functions are not available for all models.

#### Power cable

Length	Heidrive-No.
3 m	14-007-051-18-0
5 m	14-007-051-19-0
10 m	14-007-051-23-0

#### Signal cable (resolver)

Length	Heidrive-No.
3 m	14-007-051-60-0
5 m	14-007-051-62-0
10 m	14-007-051-67-0

#### Signal cable (HIPERFACE®)

Length	Heidrive-No.
3 m	14-007-051-78-0
5 m	14-007-051-80-0
10 m	14-007-051-85-0

# ■ HCB Servo Drive

## Single-phase

### ■ Specifications

	HCB 2/6-1	HCB 4/12-1	HCB 8/24-1
Voltage supply	230 V <sub>AC</sub> [± 10 %], 50...60 Hz		
Control voltage	24 V <sub>DC</sub> [± 20 %] (0.35 A)		
DC link voltage	325 V <sub>DC</sub> (with U <sub>mains</sub> = 230 V <sub>AC</sub> )		
Output power	400 W	800 W	1.6 kW
Max. output power for 2 s	1 kW	2 kW	4.8 kW
Rated output current	2 A <sub>rms</sub>	4 A <sub>rms</sub>	8 A <sub>rms</sub>
Max. output current for 2s	6 A <sub>rms</sub>	12 A <sub>rms</sub>	24 A <sub>rms</sub>
Internal brake resistor	75 Ω		30 Ω
Continuous power / pulse power	bis 2 kW		6.4 kW
External brake resistor	75 Ω, max. 2 kW		≥ 30 Ω
Holding brake	24 V <sub>DC</sub> , max. 2 A		
Dimensions servo drive H x W x D	200 x 50 x 163 mm 245 x 50 x 163 mm with mounting plate		230 x 67 x 200 mm 275 x 67 x 200 mm with mounting plate
Weight	1.5 kg		2.9 kg
Encoder evaluation	EnDAT® 2.2, HIPERFACE®, HIPERFACE DSL®, resolver, analog and digital incremental encoders with/without commutation signals, BiSS (Type C)		
Interfaces	USB 2.0, Ethernet, CAN bus, EtherCAT®, PROFINET®, MicroSD card		
Inputs / outputs	8 x digital in (24 V <sub>DC</sub> ), 2 x analog in (± 10 V) 3 x digital out (24 V <sub>DC</sub> )		
Product numbers	12-225-020-01-0	12-225-020-02-0	12-225-020-03-0

### Dimensional Drawing HCB 2/6-1 and HCB 4/12-1

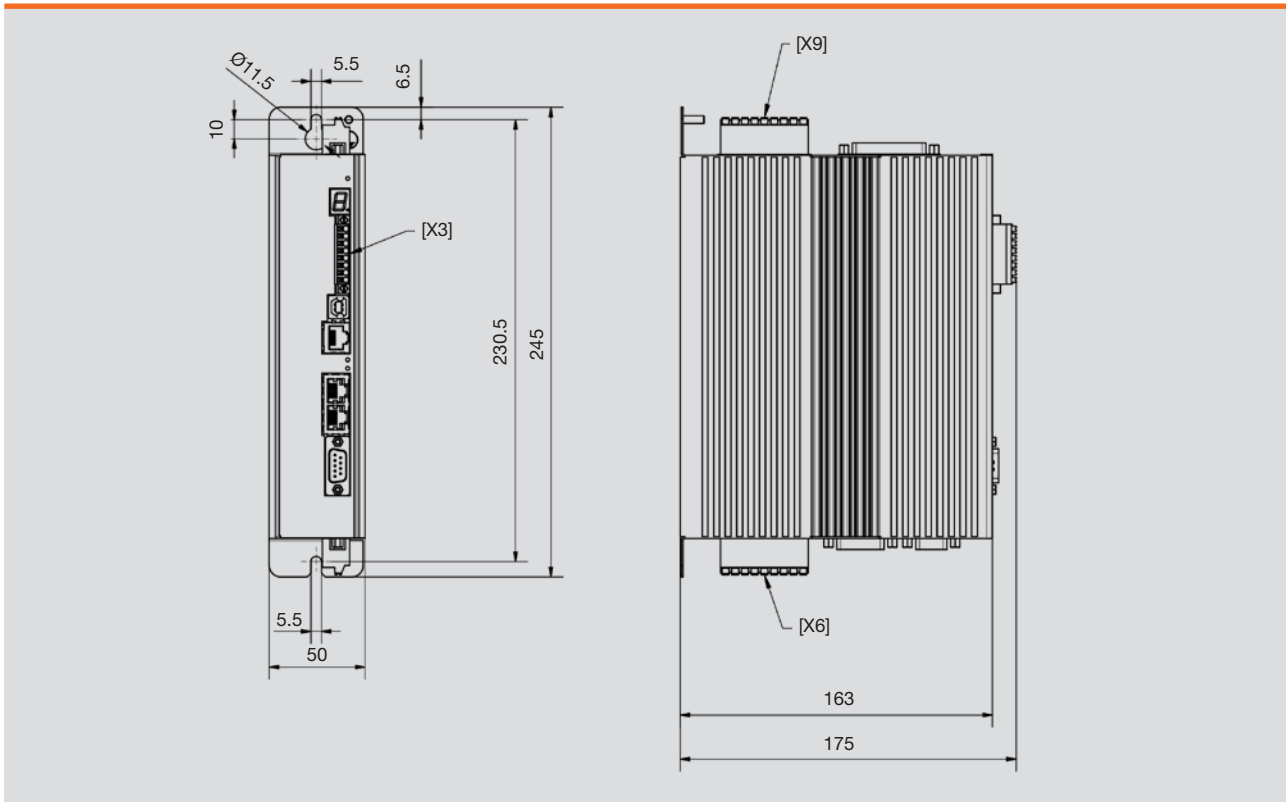

### Dimensional Drawing HCB 8/24-1

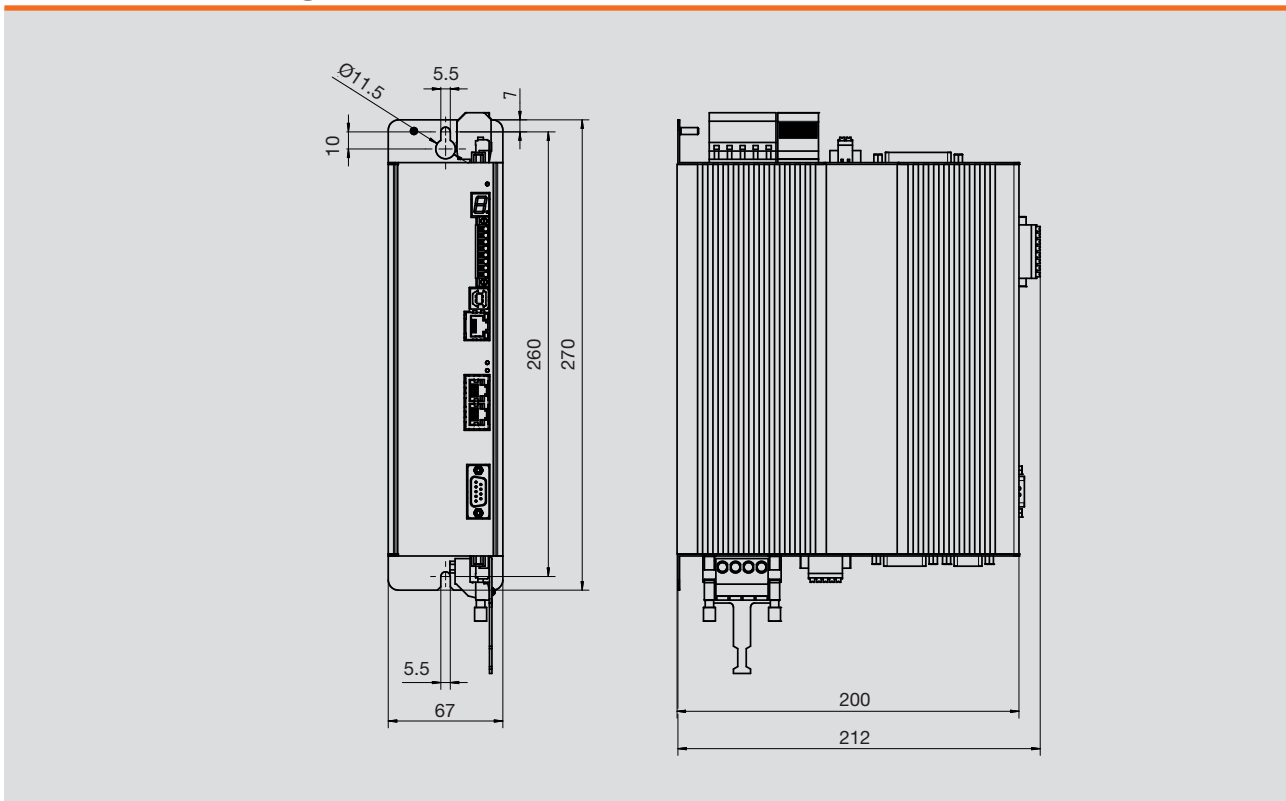

Drives

# ■ HCB Servo Drive

## Three-phase

### ■ Specifications

	HCB 4/12-3	HCB 8/24-3	HCB 12/30-3	HCB 20/50-3	HCB 40/100-3
Voltage supply	3 x 230...480 V <sub>AC</sub> [± 10 %], 45...66 Hz				
Control voltage	24 V <sub>DC</sub> [± 20 %] (0.35 A)	24 V <sub>DC</sub> [± 20 %] (0.45 A)	24 V <sub>DC</sub> [± 20 %] (0.65 A)	24 V <sub>DC</sub> [± 20 %] (max. 1 A)	
DC link voltage	565 V <sub>DC</sub> (with U <sub>mains</sub> = 400 V <sub>AC</sub> )				
Output power	1.6 kW	3.2 kW	4.8 kW	8 kW	16 kW
Max. output power for 2 s	4.8 kW	9.6 kW	12 kW	20 kW	40 kW
Rated output current	4 A <sub>rms</sub>	8 A <sub>rms</sub>	12 A <sub>rms</sub>	20 A <sub>rms</sub>	40 A <sub>rms</sub>
Max. output current for 2s	12 A <sub>rms</sub>	24 A <sub>rms</sub>	30 A <sub>rms</sub>	50 A <sub>rms</sub>	100 A <sub>rms</sub>
Internal brake resistor	30 Ω				15 Ω
Continuous power / pulse power	50 W to 24 kW			80 W	160 W
External brake resistor	≥ 30 Ω			15 Ω ≤ R <sub>ex</sub> ≤ 50 Ω	15 Ω ≤ R <sub>ex</sub> ≤ 50 Ω
Holding brake	24 VDC, max. 2A				
Dimensions servo drive H x W x D	230 x 67 x 200 mm 275 x 67 x 200 mm with mounting plate			351 x 90.5 x 256.5 mm 390 x 93 x 263 mm with mounting plate	351 x 162.5 x 256.5 mm 390 x 165 x 263 mm with mounting plate
Weight	2,9 kg		8,0 kg		13,5 kg
Encoder evaluation	EnDAT® 2.2, HIPERFACE®, HIPERFACE DSL®, resolver, analog and digital incremental encoders with/without commutation signals, BiSS (Type C)				
Interfaces	USB 2.0, Ethernet, CAN, EtherCAT®, PROFINET®, MicroSD card			USB 2.0, Ethernet, CAN, EtherCAT®, PROFINET®, MicroSD card, Ethernet Powerlink*	USB 2.0, Ethernet, CAN, EtherCAT®, PROFINET®, MicroSD card, Ethernet Powerlink*
Inputs / outputs	8 x digital in (24 V <sub>DC</sub> ), 2 x analog in (± 10 V) 3 x digital out (24 V <sub>DC</sub> )				
Product numbers	12-405-020-11-0	12-405-020-12-0	12-405-020-13-0	12-405-020-14-0	12-405-020-15-0

\* On request.

### Dimensional Drawing HCB 4/12-3, HCB 8/24-3, HCB 12/30-3

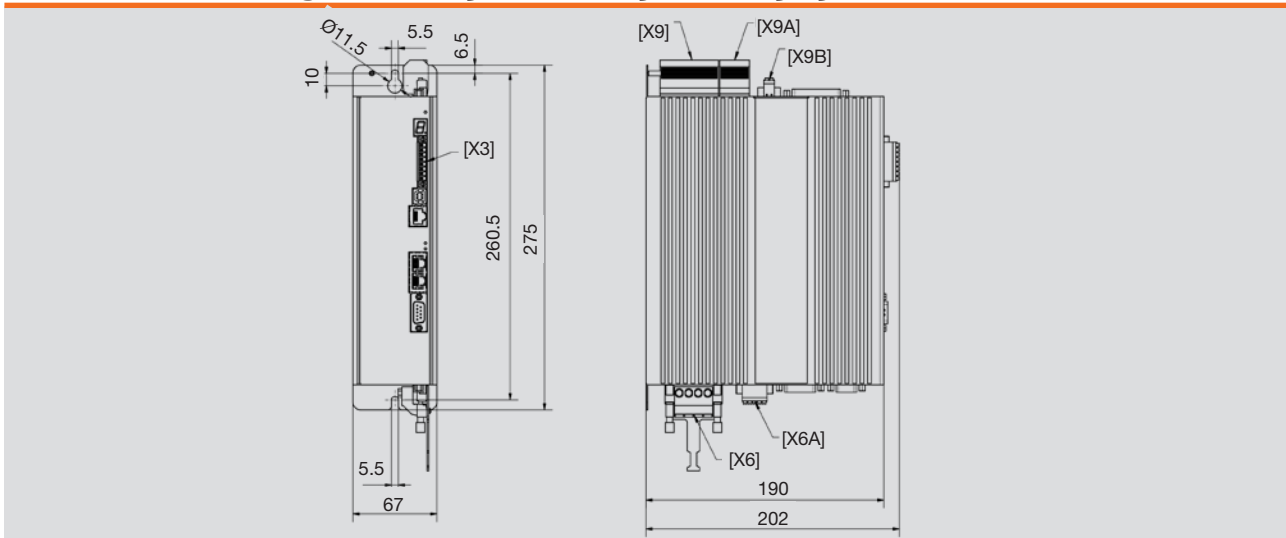

### Dimensional Drawing HCB 20/50-3

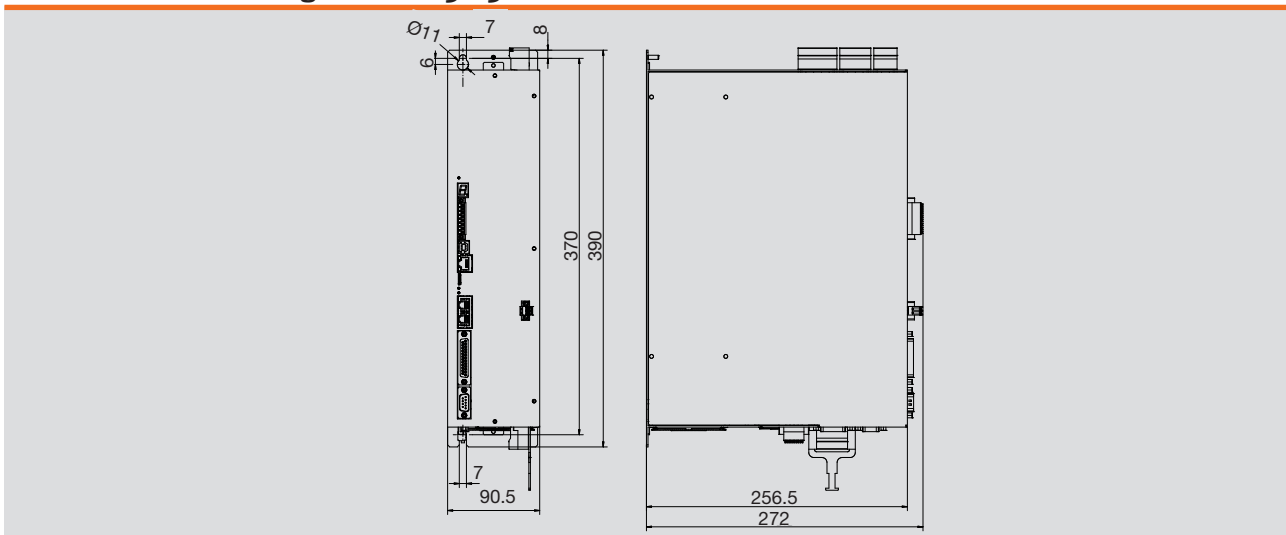

### Dimensional Drawing HCB 40/100-3

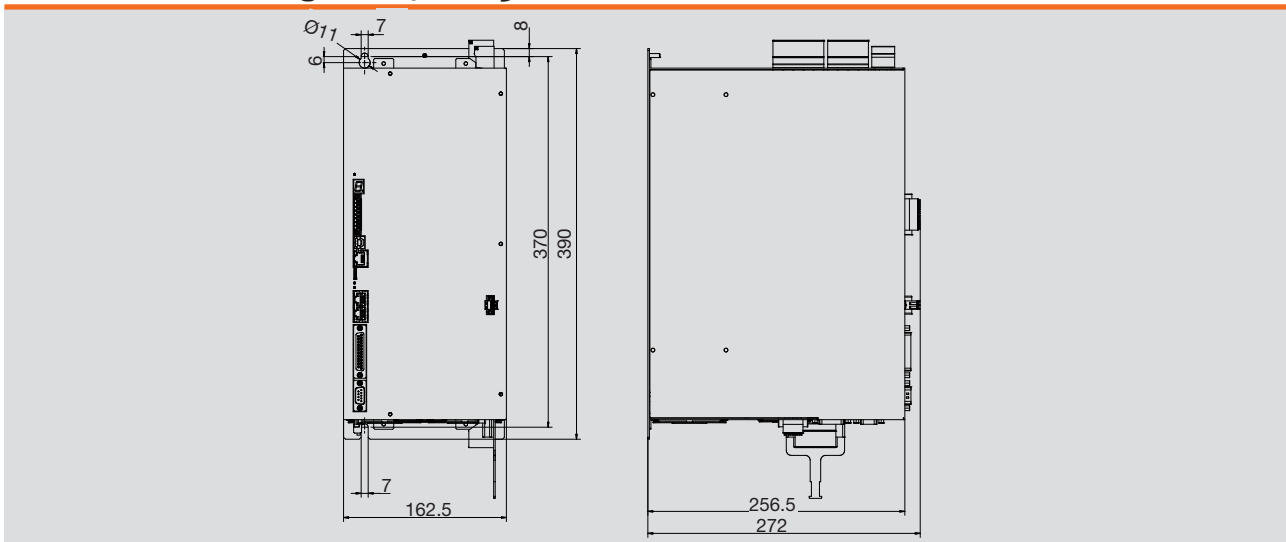

# ■ HCL Servo Drive

## ■ Introduction

In addition to the integrated controllers, the HCL servo controller series perfectly can be combined perfectly with our 24 V and 48 V motors of the HMD Next Generation series.

With a maximum current of up to 225 A peak, the controllers, in combination with our HMD servo-motors, offer an ideal solution for demanding tasks.

This solution delivers an extremely cost-efficient package that includes a certified STO interface and UL recognition.

Thanks to their freely programmable Motion Process Unit (MPU), the controllers are ideal for simple control tasks. An additional PLC is often not required. EtherCAT® or CANopen® are two of the most common and proven fieldbuses available for use with an external PLC.

## ■ Sizes



## Ambient Conditions

Protection class	IP20 except clamps (IP00)
Accident prevention regulation	In conformity with local regulations (in Germany e. g. DGUV regulation 3)
Mounting method	Installation only for vertical mounting into a switch cabinet with protection class at least IP4x, if using the safety function STO at least IP54

## Functions

- "Safe Torque Off (STO)" safety function
- Device status display via three LEDs
- Freely programmable MPU (**M**otion **P**rocess **U**nit)
  - simple PLC functionality
- Compact 4-quadrant controller
- Vector controlled
- Galvanically isolated fieldbus interfaces

## Accessories

### HCL Stick – USB/CAN Program Interface

The HCL stick connects the HCL CAN controller to your Windows® computer via its USB interface. This makes it easy to commission, parameterize and program the controller using the software tools that we provide for the controllers.

### HCL Brake – Brake Chopper for Mains-Powered Systems

The HCL brake chopper effectively cuts overvoltages and redirects braking energy to an external load resistor. To protect all components in the DC link, the overvoltage threshold can be set using a DIP switch. The maximum peak braking current is 55 A when an external 1 Ohm load resistor is connected (not included in the scope of delivery).

# ■ HCL Servo Drive

## 60 C

Specifications	HCL 60 C
Electronic supply voltage $U_e$	18 - 30 V
Power supply voltage $U_p$	9 - 60 V
Maximal output current	42.5 A <sub>rms</sub>
Continuous output current (UL/CE) ≤ 24 V	18.5 A <sub>rms</sub>
Continuous output current (UL/CE) ≤ 60 V	18.5 A <sub>rms</sub>
PWM frequency	32 KHz
PWM mode	SVPWM
Motor types	Brushless motors, linear motors
STO	Yes
Security integrity level (SIL)	SIL 3
Performance level (PL)	PL e
Fieldbus	CAN
Galvanically isolated	No
CAN protocol	DS301
Encoder supply	5 V / 0.2 A
Encoder evaluation	SSI / incremental encoder / BiSS
Number of inputs / outputs	6 digital IN / 3 digital OUT / 1 analog IN
Size	78 x 74 x 29 mm
Assembly	Wall mounted
Installation requirements	IP54
Maximum operating ambient temperature	-40 °C to 55 °C

## Dimensional Drawing

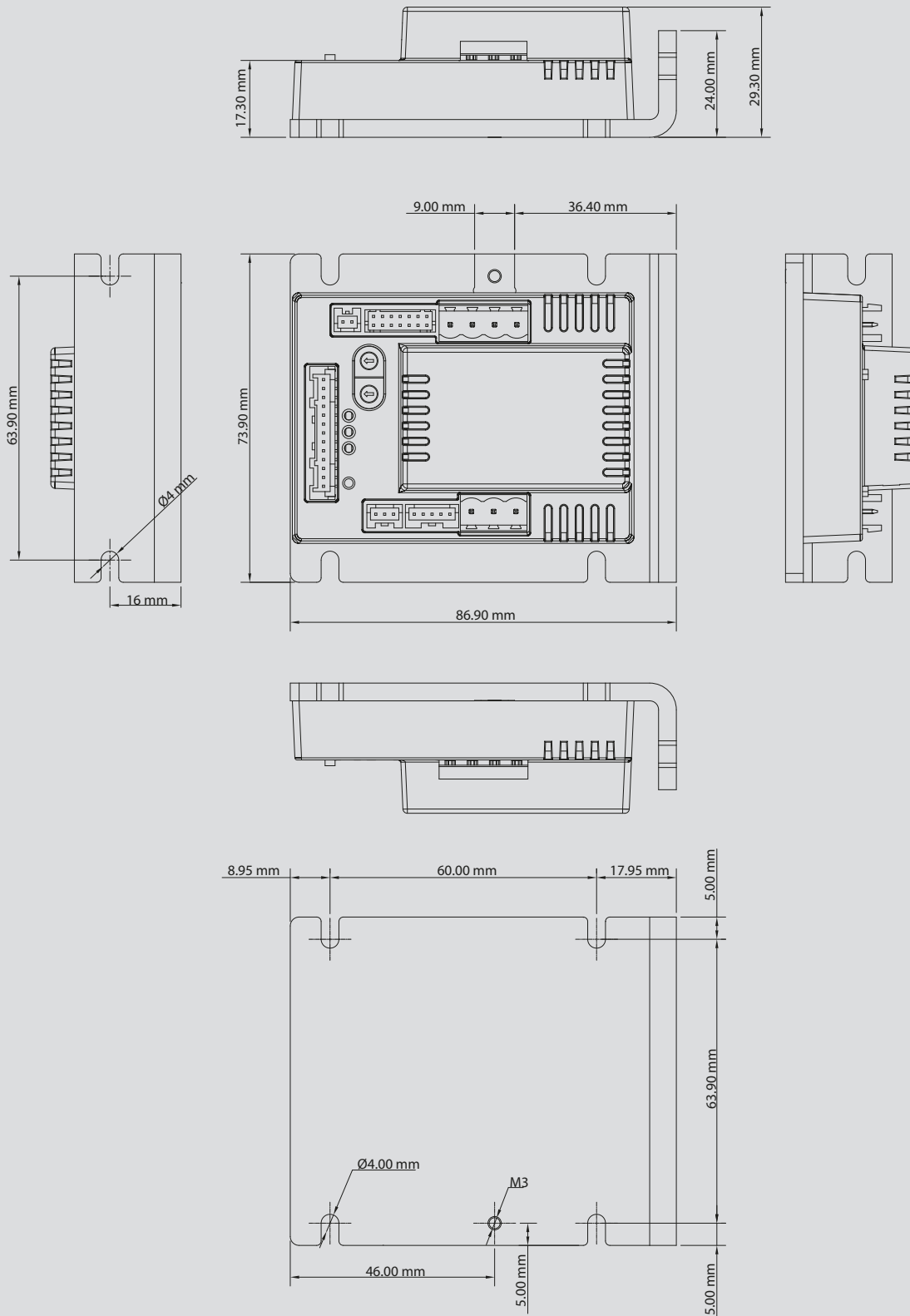

# ■ HCL Servo Drive

120 C / E

Specifications	HCL 120 C	HCL 120 E
Electronic supply voltage $U_e$	18 - 30 V	
Power supply voltage $U_p$	9 - 60 V	
Maximal output current	85 A <sub>rms</sub>	
Continuous output current (UL/CE) ≤ 24 V	-	
Continuous output current (UL/CE) ≤ 60 V	18.5 A <sub>rms</sub>	
PWM frequency	32 KHz	
PWM mode	SVPWM	
Motor types	Brushless motors, linear motors	
STO	Yes	
Security integrity level (SIL)	SIL 3	
Performance level (PL)	PL e	
Fieldbus	CAN	EtherCAT®
Galvanically isolated	No	Yes
CAN protocol	DS301	
Encoder supply	5 V / 0.2 A	
Encoder evaluation	SSI / incremental encoder / BiSS	
Number of inputs / outputs	6 digital IN / 3 digital OUT / 1 analog IN	
Size	87 x 74 x 29 mm	87 x 74 x 49 mm
Assembly	Wall mounted	
Installation requirements	IP54	
Maximum operating ambient temperature	-40 °C to 55 °C	

## Dimensional Drawing HCL 120 C

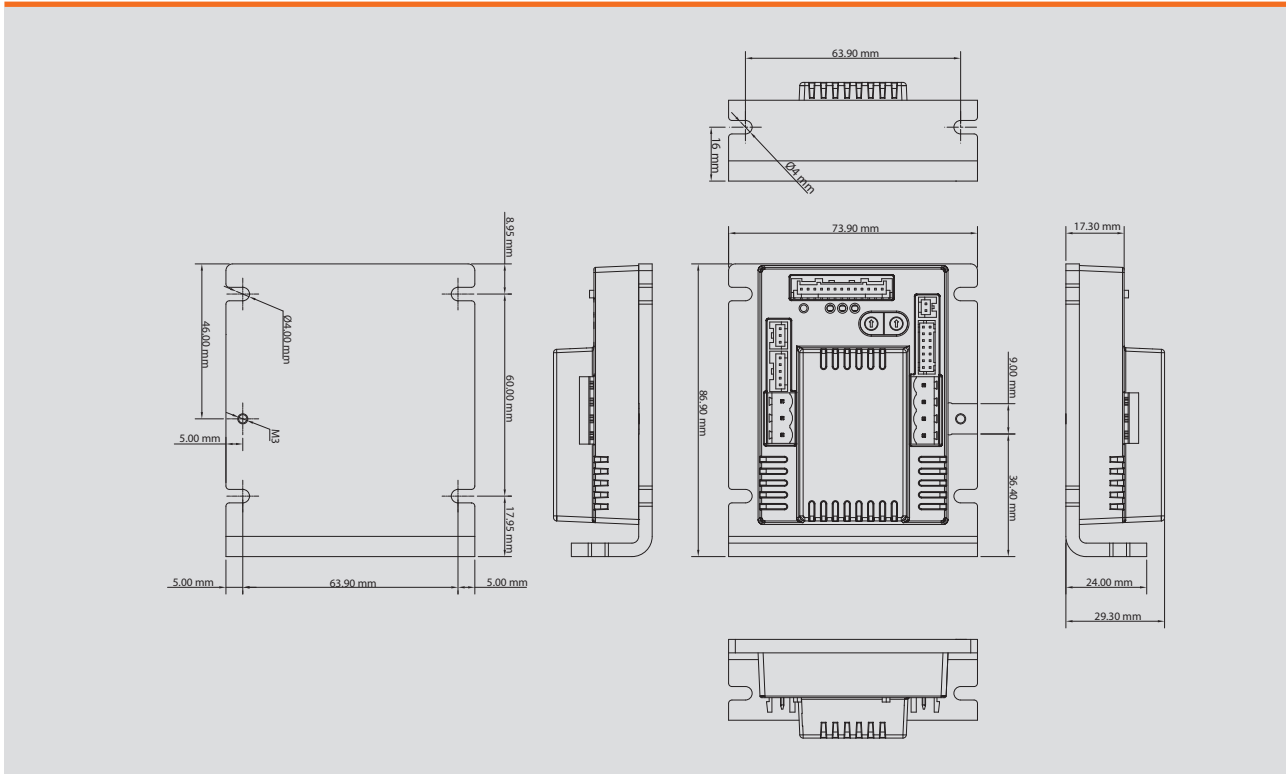

## Dimensional Drawing HCL 120 E

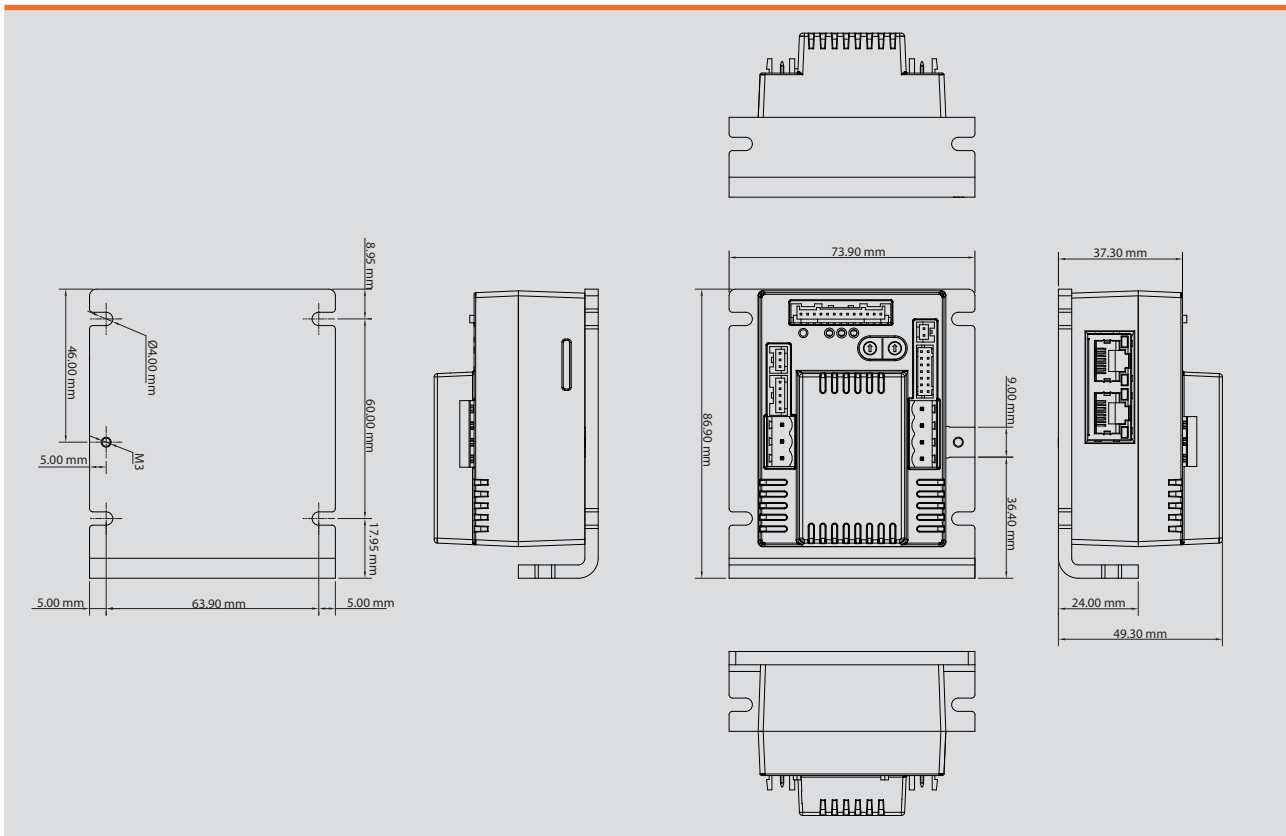

# ■ HCL Servo Drive

## 225 CS

Specifications	HCL 225 CS
Electronic supply voltage $U_e$	9 - 30 V
Power supply voltage $U_p$	9 - 60 V
Maximal output current	159 A <sub>rms</sub>
Continuous output current (UL/CE) $\leq 24$ V	54.5 A <sub>rms</sub>
Continuous output current (UL/CE) $\leq 60$ V	46 A <sub>rms</sub>
PWM frequency	32 KHz
PWM mode	SVPWM
Motor types	Brushless motors, linear motors
STO	Yes
Security integrity level (SIL)	SIL 3
Performance level (PL)	PL e
Fieldbus	CAN
Galvanically isolated	Yes
CAN protocol	DS301
Encoder supply	5 V / 0.2 A
Encoder evaluation	SSI / incremental encoder / BiSS
Number of inputs / outputs	6 digital IN / 3 digital OUT / 2 analog IN
Size	111 x 100 x 56 mm
Assembly	Wall
Installation requirements	IP54
Maximum operating ambient temperature	-40 °C to 40 °C

## Dimensional Drawing

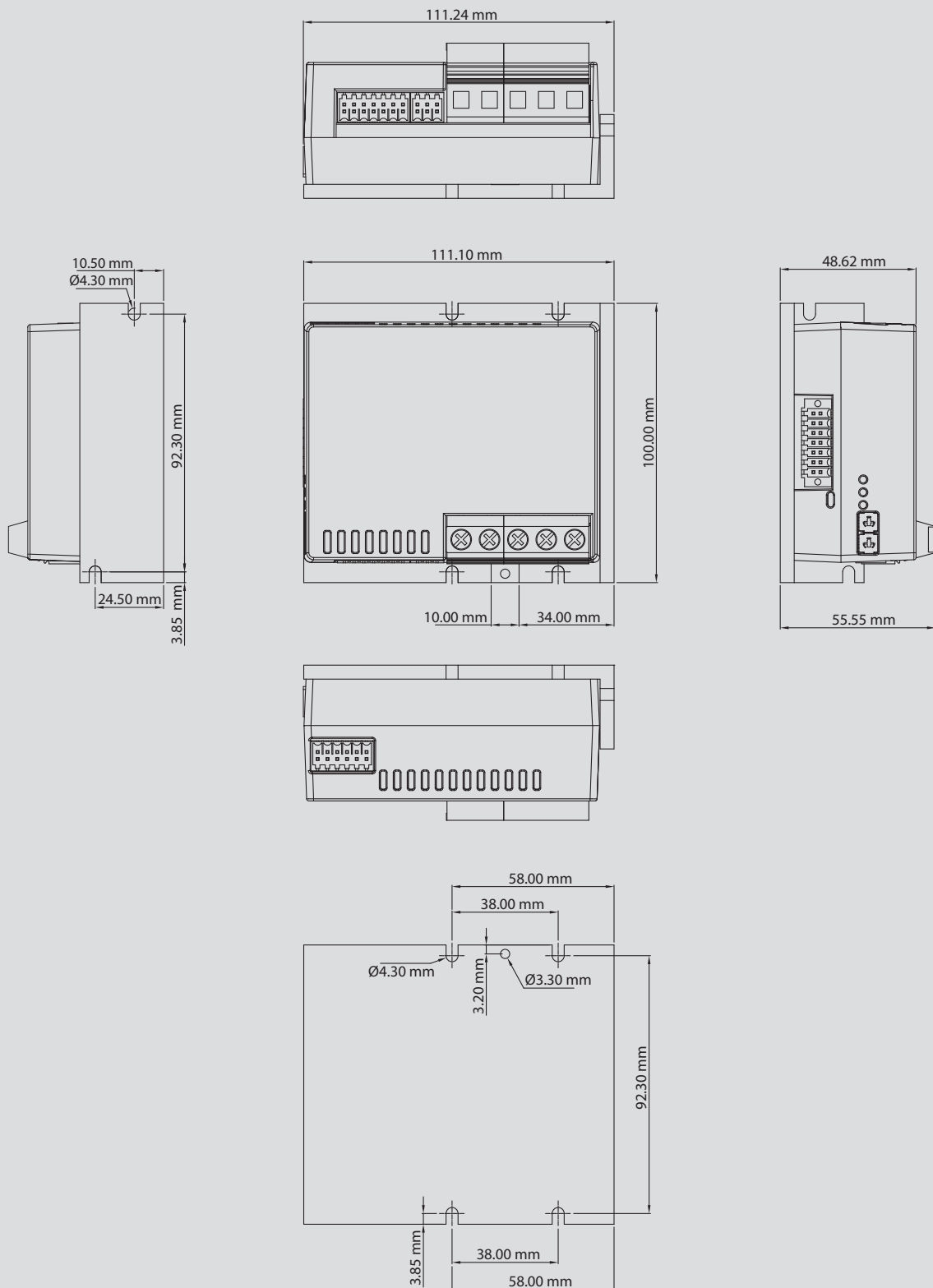

# ■ HCL Servo Drive

225 C / E

Specifications	HCL 225 C	HCL 225 E
Electronic supply voltage $U_e$	9 - 30 V	
Power supply voltage $U_p$	9 - 60 V	
Maximal output current	159 A <sub>rms</sub>	
Continuous output current (UL/CE) ≤ 24 V	54.5 A <sub>rms</sub>	
Continuous output current (UL/CE) ≤ 60 V	46 A <sub>rms</sub>	
PWM frequency	32 KHz	
PWM mode	SVPWM	
Motor types	Brushless motors, linear motors	
STO	Yes	
Security integrity level (SIL)	SIL 3	
Performance level (PL)	PL e	
Fieldbus	CAN	EtherCAT®
Galvanically isolated	Yes	
CAN protocol	DS301	
Encoder supply	5 V / 0.2 A	
Encoder evaluation	SSI / incremental encoder / BiSS	
Number of inputs / outputs	6 digital IN / 3 digital OUT / 2 analog IN	
Size	111 x 100 x 39 mm	78 x 74 x 29 mm
Assembly	Wall mounted	
Installation requirements	IP54	
Maximum operating ambient temperature	-40 °C to 40 °C	

## Dimensional Drawing HCL 225 C

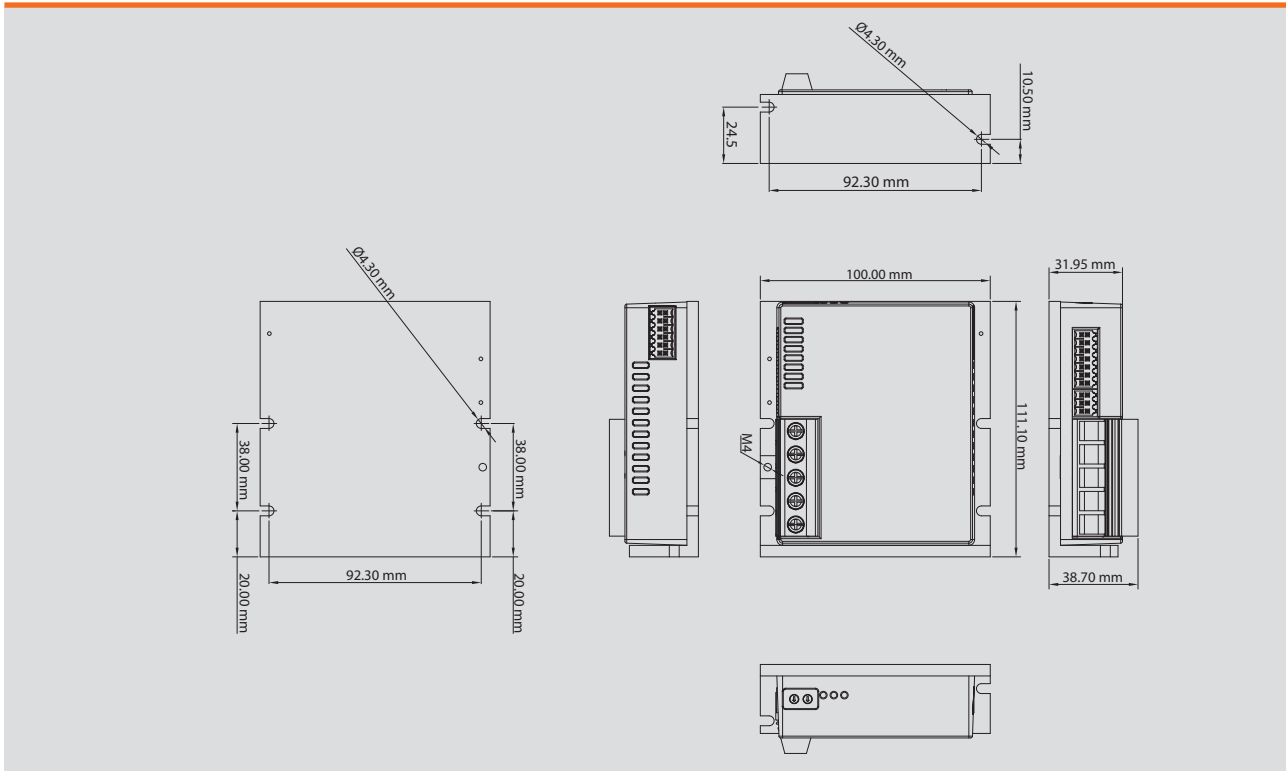

## Dimensional Drawing HCL 225 E

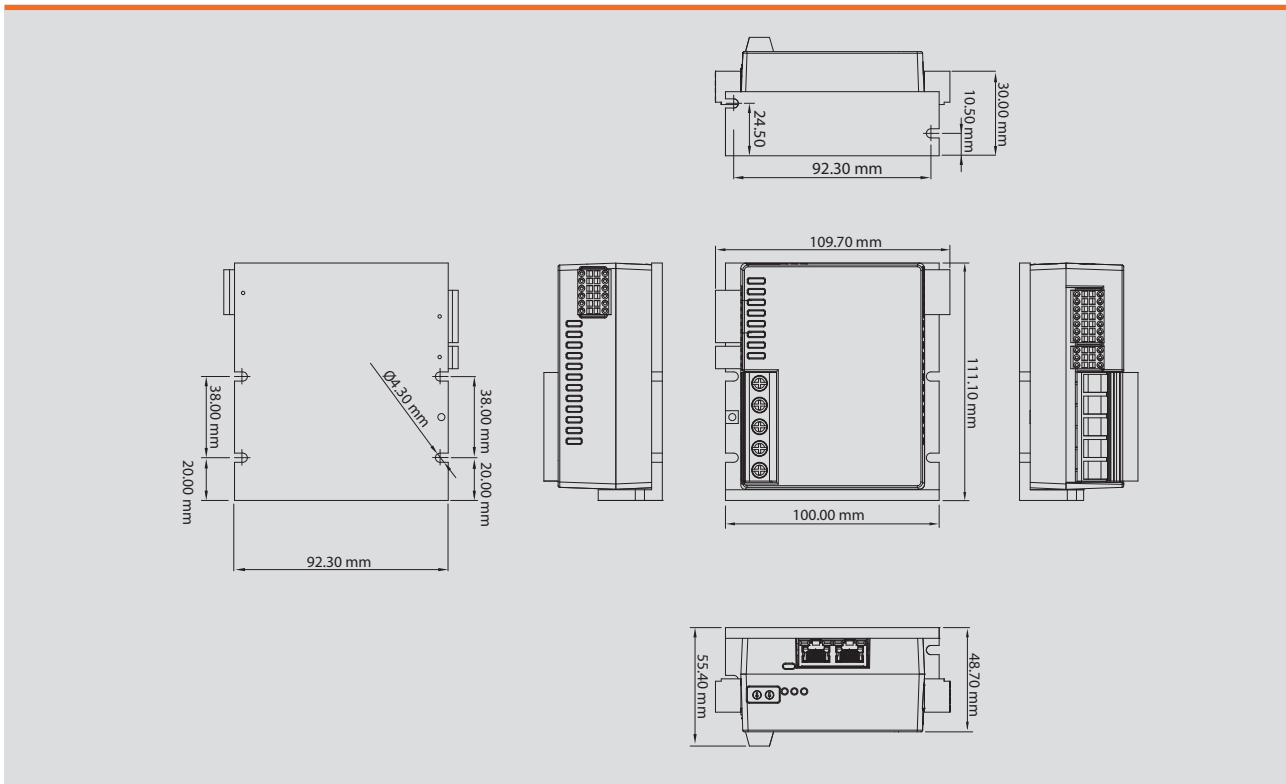

Technical data subject to change! Last changes: 04/2026

**Heidrive GmbH**

Starenstraße 23  
D-93309 Kelheim

Phone +49 9441/707-0  
Fax +49 9441/707-259

info@heidrive.de  
www.heidrive.com

